

NOTE

This manual documents the Model 8920A and 8921A True RMS Voltmeters and their assemblies at the revision levels shown in Appendix 7A. If your instrument contains assemblies with different revision letters it will be necessary to either update or backdate this manual. Refer to the supplemental change/errata sheet for newer assemblies or to the backdating sheet (Appendix 7A) for older instruments.

8920A/8921A

True RMS Voltmeter

Instruction Manual

P/N 487157
October 1978



1941



1942

1943

A

1



1

1944

1945



Table of Contents

SECTION	TITLE	PAGE
1	INTRODUCTION AND SPECIFICATIONS	1-1
1-1.	INTRODUCTION	1-1
1-9.	SPECIFICATIONS	1-2
1-11.	Specifications, Options	1-2
2	OPERATING INSTRUCTIONS	2-1
2-1.	INTRODUCTION	2-1
2-3.	SHIPPING INFORMATION	2-1
2-6.	INSTALLATION	2-1
2-8.	INPUT POWER	2-2
2-10.	CONTROLS AND INDICATORS	2-2
2-12.	OPERATING NOTES	2-4
2-14.	Fuse Replacement	2-4
2-16.	Display Indications	2-4
2-21.	Measurement Connections	2-4
2-37.	Input Signal Considerations	2-6
2-43.	Range Selection	2-6
2-50.	Voltage Display Mode	2-6
2-53.	dB Display Mode	2-6
2-56.	dBm Measurements	2-7
2-68.	Linear Analog Output	2-8
2-70.	OPERATION	2-8
3	THEORY OF OPERATION	3-1
3-1.	INTRODUCTION	3-1
3-3.	OVERALL FUNCTIONAL DESCRIPTION	3-1
3-5.	Analog Circuitry	3-1
3-10.	Digital Circuitry	3-2
3-13.	DETAILED BLOCK DIAGRAM DESCRIPTION	3-2
3-15.	Signal Conditioner	3-2
3-17.	RMS Converter	3-2
3-20.	A/D Converter	3-2
3-24.	Controller	3-5
3-42.	Display and Annunciators	3-10
3-45.	Power Supply	3-11

(continued on page ii)

TABLE OF CONTENTS (continued)

SECTION	TITLE	PAGE
4	MAINTENANCE	4-1
4-1.	INTRODUCTION	4-1
4-4.	GENERAL MAINTENANCE	4-1
4-5.	Access Information	4-1
4-7.	INPUT POWER SELECTION	4-1
4-9.	Cleaning	4-1
4-11.	Fuse Replacement	4-3
4-13.	PERFORMANCE CHECK	4-3
4-15.	Low and Midband Performance Check (Volts Display Mode)	4-3
4-17.	dB Display Mode Check	4-3
4-19.	DC Low Level Check	4-5
4-21.	AC Low Level Check	4-5
4-23.	High Frequency Response Check	4-5
4-25.	CALIBRATION	4-5
4-28.	Power Supply Calibration	4-5
4-30.	Low and Midband Accuracy Adjustments	4-10
4-32.	Linear Analog Output (8920A only)	4-10
4-34.	AC Low Level Calibration	4-10
4-36.	High Frequency Calibration	4-13
4-38.	RMS Protection Circuit Calibration	4-13
4-40.	TROUBLESHOOTING	4-14
4-44.	RMS Sensor Replacement	4-15
4-46.	A D Calibration Resistor Selection	4-19
4-48.	DC Offset Resistor Selection	4-19
5	LIST OF REPLACEABLE PARTS	5-1
5-1.	INTRODUCTION	5-2
5-4.	HOW TO OBTAIN PARTS	5-2
6	OPTION AND ACCESSORY INFORMATION	6-1
7	GENERAL INFORMATION	7-1
7A-1	MANUAL CHANGE INFORMATION	7A-1
8	SCHEMATIC DIAGRAMS	8-1

List of Tables

TABLE	TITLE	PAGE
1-1.	8920A/8921A Option	1-1
1-2.	8920A/8921A Accessories (for C size instruments)	1-2
1-3.	8920A/8921A Specifications	1-2
1-4.	8920A/8921A Option Specifications	1-6
2-1.	Rack Mounting Kits	2-1
2-2.	Controls, Indicators and Connectors	2-3
3-1.	Signal Conditioner Gain Configuration	3-4
3-2.	Controller Summary	3-7
3-3.	Output Range Codes	3-9
3-4.	Over Underload Conditions	3-9
3-5.	Input Range Codes	3-9
4-1.	Recommended Test Equipment	4-2
4-2.	Input Power Selection	4-2
4-3.	Low and Midband Performance Check (Volts Display Mode)	4-4
4-4.	dB Display Mode Check	4-6
4-5.	DC Low Level Check	4-7
4-6.	High Frequency Response Check	4-10
4-7.	Low and Midband Accuracy Adjustments	4-11
4-8.	High Frequency Calibration	4-13
4-9.	8920A/8921A Troubleshooting Procedure	4-16
4-10.	Attenuator Logic States	4-19
4-11.	R204 Resistive Values (mF, $\pm 1\%$, 1.8W)	4-20
4-12.	R19 R34, R66 R76 Resistive Values (mF, $\pm 1\%$, 1.8W)	4-20
603-1.	Recommended Test Equipment	603-2
603-2.	Counter Output Amplitude	603-5
603-3.	Counter Output Frequency Response	603-5
603-4.	Counter Output Option Troubleshooting	603-6
603-5.	Counter Output Option PCB Assembly	603-9
604-1.	Performance Test	604-3
604-2.	Logarithmic Analog Output Option PCB Assembly	604-5

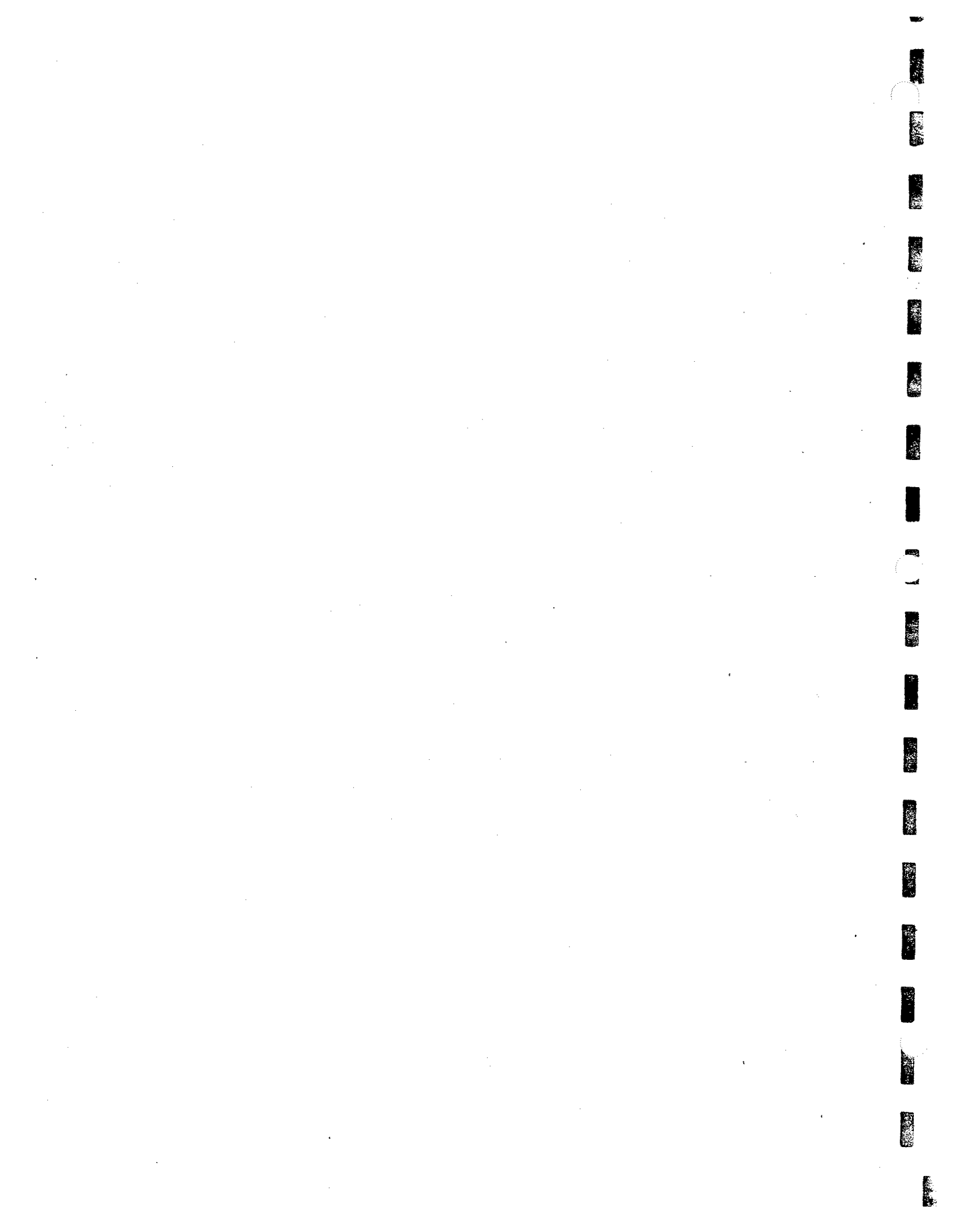

List of Illustrations

FIGURE	TITLE	PAGE
	Frontispiece	vi
2-1.	PTI Connection	2-1
2-2.	Controls, Indicators and Connectors	2-2
2-3.	Matched Impedance Measurement Techniques	2-5
2-4.	Typical Relative dB Measurements	2-7
3-1.	Overall Block Diagram	3-1
3-2.	Detailed Block Diagram	3-3
3-3.	Signal Conditioner	3-4
3-4.	RMS Converter	3-5
3-5.	A/D Converter, Simplified Schematic and Timing	3-6
3-6.	Controller Timing (A/D Converter)	3-7
3-7.	Controller Functions	3-8
3-8.	Display and Annunciators	3-10
4-1.	Low and Midband Performance Test Set-Up	4-3
4-2.	DC Low Level Check Test Set-Up	4-6
4-3.	AC Low Level Check Test Set-Up	4-7
4-4.	High Frequency Response Check Test Set-Up	4-7
4-5.	Calibration and Test Point Location	4-8
4-6.	Linear Analog Output Test Set-Up (8920A only)	4-12
4-7.	High Frequency Calibration Test Set-Up	4-14
4-8.	A/D Waveforms (General Condition)	4-18
603-1.	Counter Output Option Installation	603-2
603-2.	Counter Output Option Simplified Schematic	603-3
603-3.	Counter Output Performance Set-Up	603-4
603-4.	Counter Output Performance Test Set-Up	603-4
603-5.	Calibration Set-Up	603-5
603-6.	Counter Output Option PCB Assembly	603-10
604-1.	Logarithmic Analog Output Option Installation	604-2
604-2.	Logarithmic Analog Output Option Simplified Schematic	604-3
604-3.	Logarithmic Analog Output Option Test Set-Up	604-4
604-4.	Logarithmic Analog Output Option PCB Assembly	604-6

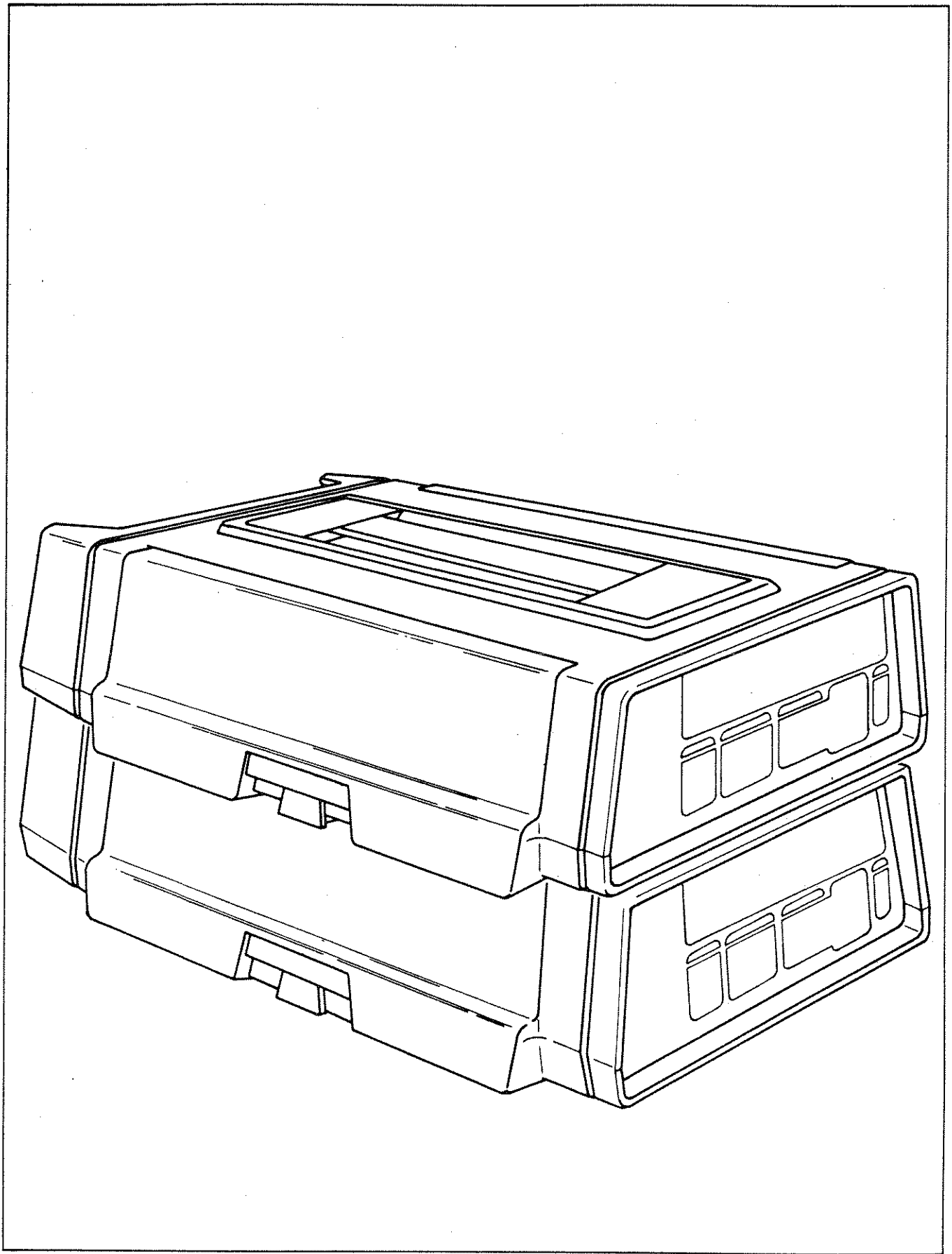

Frontispiece

Introduction & Specifications

1-1. INTRODUCTION

NOTE

Unless otherwise specified, all information, figures, tables and general data presented in this manual are applicable to both Model 8920A and 8921A True RMS Voltmeters.

1-2. The Models 8920A and 8921A are digital true rms voltmeters, capable of accurately measuring the true rms value of nonsinusoidal signals containing AC or AC + DC components. Both have a frequency range of 10 Hz to 20 MHz with a full-scale crest factor of seven, and are capable of displaying measurements in either volts or dB units.

1-3. Selecting the VOLTS position on the dB VOLTS switch enables the volts display mode and three applicable front panel annunciators (V, mV, and 2 MHz MAX). In this mode, the instruments display a 3 1/2 digit figure to indicate the true rms value of any AC or AC + DC input signal whose amplitude is between 180 μ V and 700V rms (1000V peak).

1-4. The dB display mode (logarithmic) is enabled when dB is selected on the front panel dB VOLTS display switch. In this mode, the instruments display a 4 1/2 digit dBm value of the input signal referenced to 1-of-12 manually selected impedances (50 to 1200 ohms). The dB display mode also uses three annunciators, dB, RELATIVE REFERENCE, and 2 MHz MAX, to establish the instrument's operating status. The RELATIVE REFERENCE annunciatory lights whenever the REL switch is depressed to indicate that any further dB measurements will be referenced to the voltage present at the time the switch was pressed. When AUTO is selected on the AUTO/HOLD switch (the out position) the autorange mode selects one-of-seven input ranges to optimize the display.

1-5. Complementing the instrument's high digital resolution is an analog panel meter for use in applications that require peaking or nulling. This meter does not have calibration markings since it is intended for peaking and nulling indications only.

1-6. Note that both the 8920A and 8921A accommodate floating measurements. The 8921A safely accepts common mode inputs up to 500V rms, or 700V peak. An isolation circuit allows the 8920A input low to float up to approximately 0.6V peak with respect to earth ground. Isolation of 0.6V peak will accommodate the few hundred millivolts of typical common mode voltage. Full operator protection is still maintained since under fault conditions the diode isolation circuitry conducts and insures that the common mode voltage is never greater than one diode drop.

1-7. Several options and accessories are available for use with the 8920A and 8921A. The options and accessories are listed and described in Table 1-1 and Table 1-2. They may be ordered for factory or field installation. Detailed information concerning each option and accessory is given in Section 6 of this manual.

Table 1-1. 8920A/8921A Options

OPTION	DESCRIPTION	COMMENT
8920A/ 8921A-003	Counter Output	Available in both 8920A & 8921A.
8920A-004	Logarithmic Analog Output	Available in 8920A only.

**Table 1-2. 8920A/8921A Accessories
(for C size instruments)**

ACCESSORY MODEL NO.	DESCRIPTION
Y2014	Rack Mounting Kit (single unit)
Y2015	Rack Mounting Kit (double unit)
Y2020	Panel Adapter (DIN size)

1-8. The PTI (Portable Test Instrument) case is a family of injection molded, plastic instrument packages of various sizes which may be stacked vertically and latched together to form portable test stations. When

instruments are stacked they should be limited to 40 pounds total, and the instrument drawing the most power should be on the top. Stacked instruments have a horizontal air space between them to reduce heat conduction between instruments.

1-9. SPECIFICATIONS

1-10. Detailed specifications for the Models 8920A and 8921A True RMS Voltmeter are given in Table 1-3.

1-11. Specifications, Options

1-12. Detailed specifications for the Models 8920A and 8921A's options are given in Table 1-4.

Table 1-3. 8920A/8921A Specifications

ELECTRICAL (Basic)	
The electrical specifications given assume an operating temperature of 23°C ±5°C, relative humidity up to 80% and a minimum 90 day calibration cycle.	
FUNCTIONS	AC true RMS, AC + DC true RMS
DISPLAY	Digital Display, Panel selectable for volts or dB: analog peaking/nulling meter.
RANGING	Autoranging, Hold to defeat Autoranging, step-up for manual up-ranging.
AUTORANGING POINTS	Ranging up at 2000 counts. Ranging down at 180 counts.
MAXIMUM INPUT	700V rms or 1000V peak, not to exceed 1 X 10 ⁸ volts-Hz product on any range.
RESPONSE TYPE	True RMS thermal converter, will accept: sine, complex, pulse or random waveforms.
RESPONSE TIME	1.6 seconds typically to rated accuracy within a range, composed of 1 second settling time and 0.6 seconds maximum digitizing time.
INPUT IMPEDANCE	2 mV to 700V range = 10 MΩ/shunted by < 30 pF.
CREST FACTOR	7 at full scale, increasing down scale by: 7 X V range ÷ V input.
FREQUENCY RANGE	2 mV range – 2 MHz maximum. 20 mV – 20V range = 20 MHz maximum. 200V – 700V range = 1 MHz maximum.
ELECTRICAL (VOLTS Display Mode)	
RANGES	2 mV, 20 mV, 200 mV, 2V, 20V, 200V and 700V.
RESOLUTION	0.05% of range.

Table 1-3. 8920A/8921A Specifications (cont)

ELECTRICAL (dB Display Mode)

dB RANGE In the autorange mode the instrument appears as though it has a single range spanning 132 dB. Transients will appear in the readout as the transition through which the analog voltage range points occur.

dB RANGE REFERENCES:

dBm REFERENCES Twelve manually selectable impedances with which to reference a 0 dBm, 1 mW signal level. Impedances are 50, 75, 93, 110, 124, 135, 150, 300, 600, 900, 1000 and 1200 ohms.

RELATIVE dB REFERENCE A voltage present when this switch is depressed to its REL position is held as 0 dB reference for all other voltages.

dB RESOLUTION 0.01 dB.

ACCURACY

The accuracy specifications given below apply to the volts and dB display modes at 9% to 100% of full scale, 23°C ±5°C, 90 days.

Table -1. AC: ±% of Voltage Reading or ±dB

INPUT VOLTAGE	RANGE	AC ACCURACY:							
		10 Hz	20 Hz	50 Hz	200 kHz	1 MHz	2 MHz	10 MHz	20 MHz
180-700V 18.0-199.9	700V 200V	5% 0.5 dB	1% 0.15 dB	0.5% 0.1 dB	0.7% 0.15 dB	NOT SPECIFIED			
1.80-19.99 .180-1.999 18.0-199.9 mV	20V 2V 200 mV					3% 0.35 dB		5% 0.5 dB	
1.80-19.99 mV	20 mV					4% 0.4 dB			
.180-1.999 mV	2 mV					3% 0.35 dB		NOT SPECIFIED	
		10 Hz	20 Hz	50 Hz	200 kHz	1 MHz	2 MHz	10 MHz	20 MHz

Temperature Coefficients: 20 Hz - 1 MHz .07%/°C; .006 dB/°C

(0°C-18°C, 28°C-50°C): 1 MHz - 20 MHz .1%/°C; .01 dB/°C

Table 1-3. 8920A/8921A Specifications (cont)

Table -2. AC + DC: $\pm\%$ of Voltage Reading or \pm dB

INPUT VOLTAGE	RANGE	AC + DC ACCURACY:							
		10 Hz	20 Hz	50 Hz	200 kHz	1 MHz	2 MHz	10 MHz	20 MHz
180-700V 18.0-199.9	700V 200V						NOT SPECIFIED		
1.80-19.99 .180-1.999 18.0-199.9 mV	20V 2V 200 mV	3% 0.35 dB					5% 0.5 dB		
1.80-19.99 mV	20 mV								
.180-1.999 mV	2 mV	See Table -3							
		10 Hz	20 Hz	50 Hz	200 kHz	1 MHz	2 MHz	10 MHz	20 MHz

NOTE: DC only measurements can also be made using the 100 Hz accuracy specification.

Temperature Coefficients: 2 mV range: 5%/°C; .5 dB/°C

(0°C-18°C, 28°C-50°C): 20 mV range and above: .5%/°C; .05 dB/°C

Table -3. AC + DC Accuracy (2 mV range)

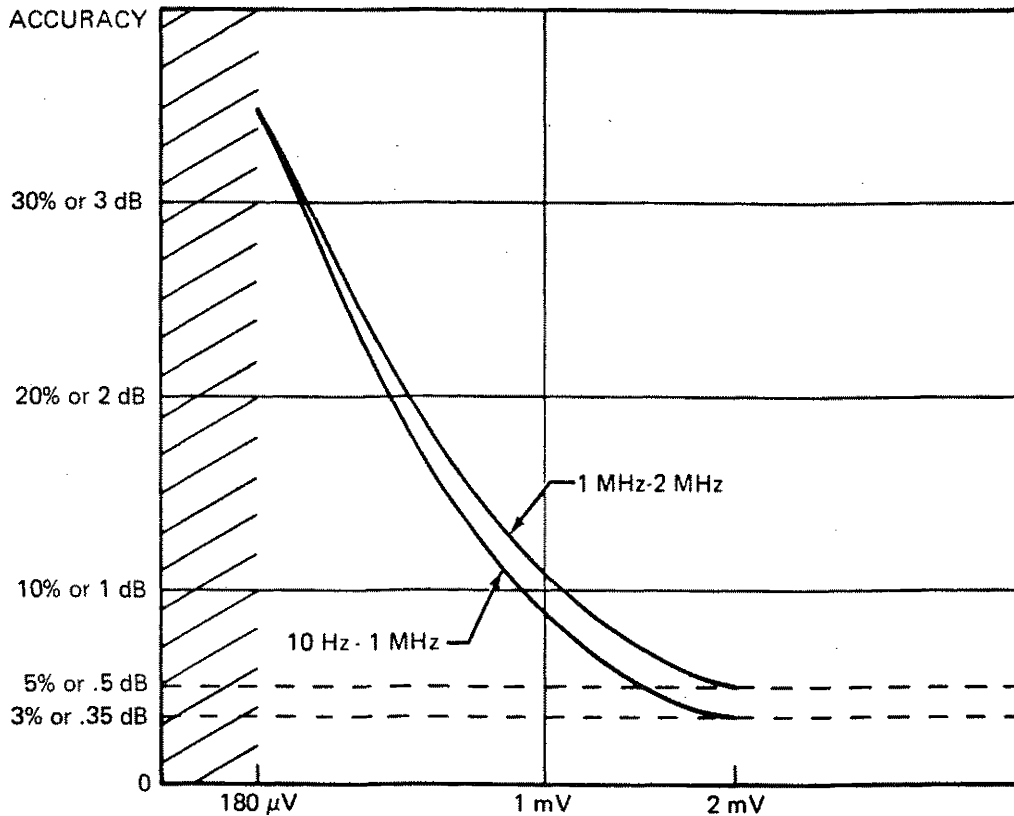

Table 1-3. 8920A/8921A Specifications (cont)

GENERAL

INPUT	8920A isolated BNC input floating up to .6V peak. 8921A isolated dual banana plus ground jack input.
DISPLAYS	5, 0.3" high, digit, 7-segment LEDs with automatic decimal point location and mV, V, dB, RELATIVE REFERENCE, and "2 MHz max annunciators". The display also incorporates an uncalibrated analog meter for nulling and peaking.
AUTORANGING RATE:	
VOLTS	700 ms max/range change; 2.2 sec max for 6 range changes.
dB	950 ms max/range change; 2.9 sec max for 6 range changes.
READING RATE	2.5 readings per second.
OVERRANGE INDICATION	Flashes maximum allowed reading for that range.
UNDERRANGE INDICATION	Flashes decimal point, but continues to display the reading.
MAXIMUM COMMON MODE	
VOLTAGE	8920A: 400 mV rms or 600 mV peak. 8921A: 500V rms or 700V peak.
INPUT COMMON MODE	
REJECTION	> 80 dB @ 50 or 60 Hz (with 100 ohms in either lead).
LINEAR ANALOG OUTPUT	
(8920A ONLY)	Each range provides a linear output with 2V dc equal to 2000 counts on the readout, $\pm 1.0\%$ of reading relative to display; essentially 0 ohm output resistance into a $>10\text{ k}\Omega$ load; non-isolated with output common the same as input common; provided only on the 8920A.
STORAGE TEMPERATURE	-40°C to $+75^{\circ}\text{C}$.
OPERATING TEMPERATURE	0°C to 50°C .
HUMIDITY RANGE	80% RH.
MTBF	Greater than 10,000 hours.
POWER	100V ac $\pm 10\%$, 120V ac $\pm 10\%$, 220V ac $\pm 10\%$, or 240V ac $\pm 10\%$ to 250V ac max. selected by internal switches, 45 to 440 Hz, 10 W max.
DIMENSIONS	40.3 cm (12.9 in.) long X 20.3 cm (8.0 in.) wide X 10.8 cm (4.3 in.) high.
WEIGHT	2.47 Kgm (5 lb. 7 oz.)

Table 1-4. 8920A/8921A Option Specifications

OPTION -003, COUNTER OUTPUT OPTION

OUTPUT VOLTAGE: 100 mV peak square wave.

OUTPUT IMPEDANCE: 50 ohms.

MAXIMUM ISOLATED LEVEL: 500 volts ac.

COMPATIBILITY: 8920A and 8921A.

OPTION -004, LOGARITHMIC ANALOG OUTPUT OPTION (8920A ONLY)

OUTPUT VOLTAGE DC:

200 μ V rms input = 0 dB, 0V dc out.

700V rms input = 131 dB, 13.1V dc out

i.e., 100 mV = 1 dB.

LINEARITY:

Within each Range: ± 0.35 dB.

Over all seven Ranges: ± 2 dB.

OUTPUT IMPEDANCE: 1 k Ω .

COMPATIBILITY: 8920A ONLY.



static awareness



A Message From
John Fluke Mfg. Co., Inc.

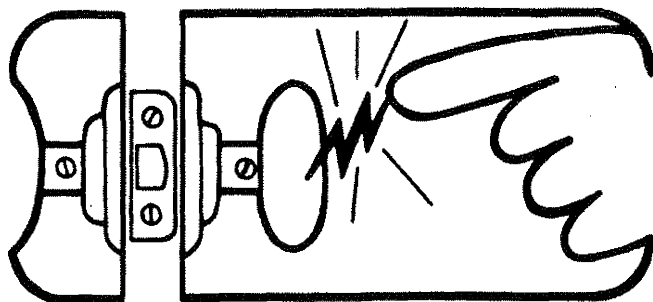

Some semiconductors and custom IC's can be damaged by electrostatic discharge during handling. This notice explains how you can minimize the chances of destroying such devices by:

1. Knowing that there is a problem.
2. Learning the guidelines for handling them.
3. Using the procedures, and packaging and bench techniques that are recommended.

The Static Sensitive (S.S.) devices are identified in the Fluke technical manual parts list with the symbol "⊗"

The following practices should be followed to minimize damage to S.S. devices.

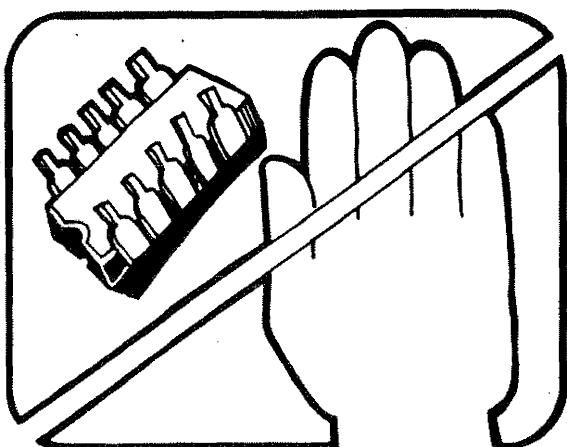

1. MINIMIZE HANDLING

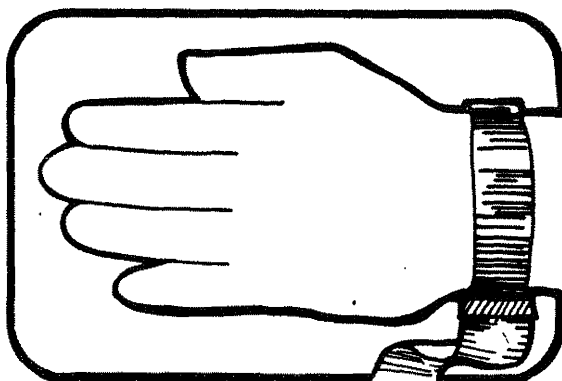

3. DISCHARGE PERSONAL STATIC BEFORE HANDLING DEVICES. USE A HIGH RESISTANCE GROUNDING WRIST STRAP.

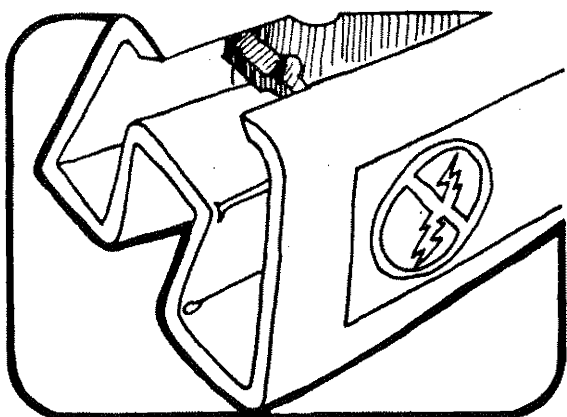

2. KEEP PARTS IN ORIGINAL CONTAINERS UNTIL READY FOR USE.

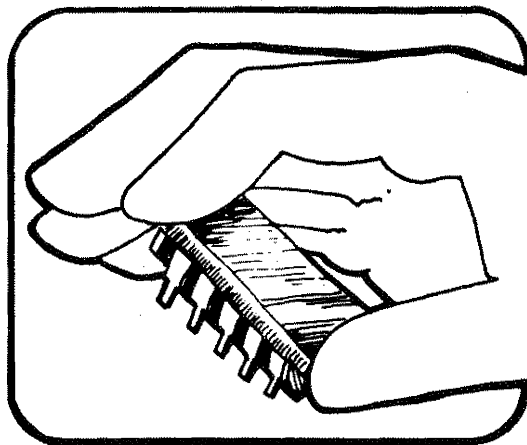

4. HANDLE S.S. DEVICES BY THE BODY

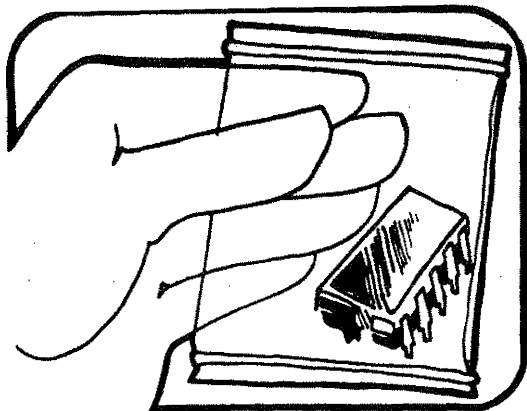

5. USE STATIC SHIELDING CONTAINERS FOR HANDLING AND TRANSPORT

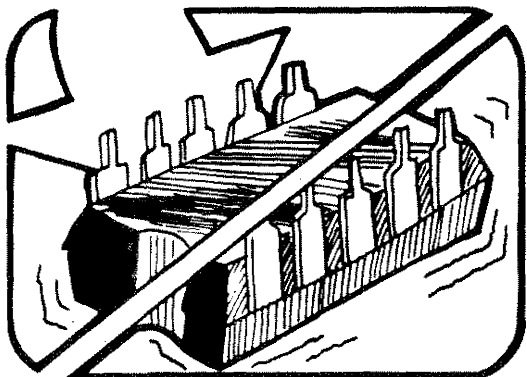

6. DO NOT SLIDE S.S. DEVICES OVER ANY SURFACE

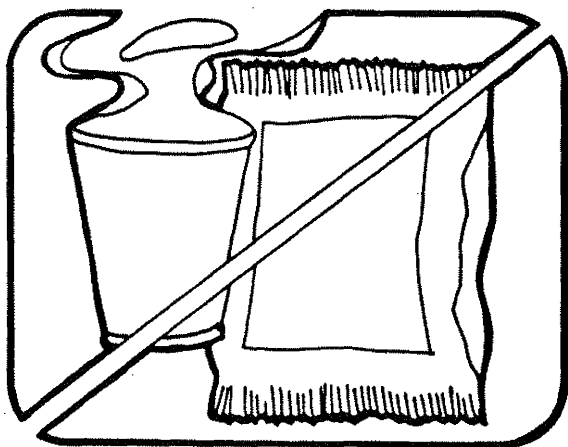

7. AVOID PLASTIC, VINYL AND STYROFOAM® IN WORK AREA

PORTIONS REPRINTED
WITH PERMISSION FROM TEKTRONIX, INC.
AND GENERAL DYNAMICS, POMONA DIV.

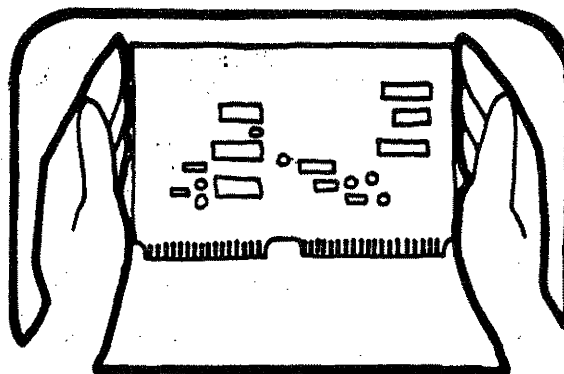

8. WHEN REMOVING PLUG-IN ASSEMBLIES, HANDLE ONLY BY NON-CONDUCTIVE EDGES AND NEVER TOUCH OPEN EDGE CONNECTOR EXCEPT AT STATIC-FREE WORK STATION. PLACING SHORTING STRIPS ON EDGE CONNECTOR HELPS TO PROTECT INSTALLED SS DEVICES.

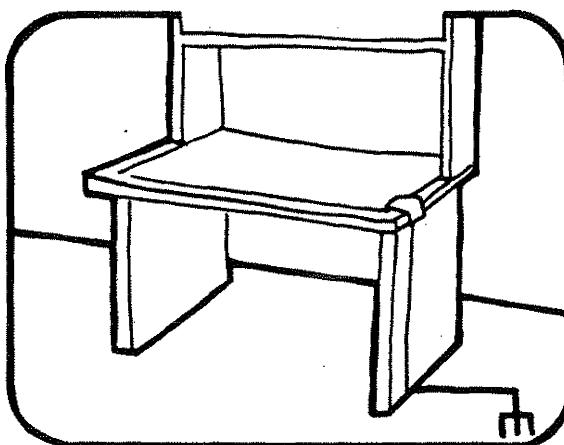

9. HANDLE S.S. DEVICES ONLY AT A STATIC-FREE WORK STATION
10. ONLY ANTI-STATIC TYPE SOLDER-SUCKERS SHOULD BE USED.
11. ONLY GROUNDED TIP SOLDERING IRONS SHOULD BE USED.

A complete line of static shielding bags and accessories is available from Fluke Parts Department, Telephone 800-526-4731 or write to:

JOHN FLUKE MFG. CO., INC.
PARTS DEPT. M/S 86
9028 EVERGREEN WAY
EVERETT, WA 98204

Operating Instructions

2-1. INTRODUCTION

2-2. The information we have presented in this section is intended to familiarize you with the capabilities and limitations of the Models 8920A and 8921A. We have included instructions for the installation and operation of both models as well as a brief description and identification of each control and indicator on the instrument.

2-3. SHIPPING INFORMATION

2-4. The Models 8920A and 8921A are packaged and shipped in a protective container. When you receive the equipment, make a thorough inspection for any possible shipping damage.

2-5. If you determine reshipment of the instrument is necessary, we recommend that you use the original container. If the original container is not available, a new one may be obtained from the John Fluke Mfg. Co., Inc. Please indicate the instrument's model number (8920A or 8921A) when requesting a new shipping container.

2-6. INSTALLATION

2-7. The 8920A and 8921A were designed for bench-top use, or for installation in a standard 19-inch equipment rack or panel mounted into any DIN size opening. Available rack mounting kits are listed in Table 2-1. In bench-top environments the 8920A, 8921A may be stacked with other Fluke products that use the PTI case. To connect two or more PTI cases, pull the side connectors out, place one case squarely on top of another

and press in on the side connectors of the top case until they seat firmly into the slots on the case below. See Figure 2-1.

CAUTION

Before you attempt to lift a series of stacked instruments, check each unit to ensure that its case connectors are properly mated and latched to the next lower instrument.

Table 2-1. Rack Mounting Kits

MODEL NO.	DESCRIPTION
Y2014	Rack Mounting Kit (single unit)
Y2015	Rack Mounting Kit (double unit)
Y2020	Panel Adapter (DIN size)

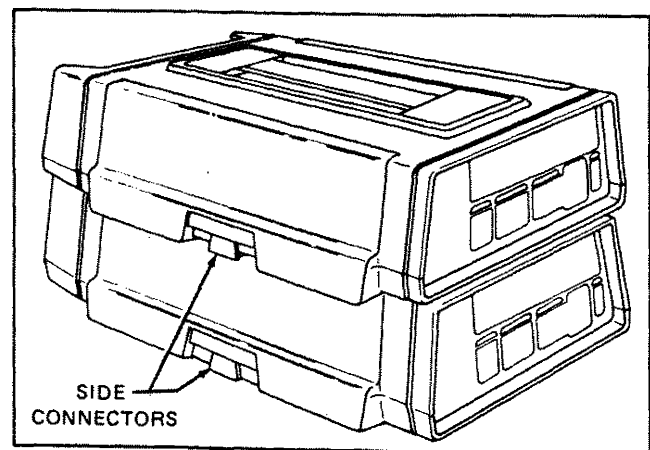

Figure 2-1. PTI Connection

2-8. INPUT POWER

2-9. The 8920A and 8921A can be operated from any one of your line voltages (100, 120, 220 or 240V). There is a procedure in Section 4, which describes how to alter the line power configuration of the instrument. We do, however, recommend that this procedure be performed by qualified personnel only.

2-10. CONTROLS AND INDICATORS

2-11. The 8920A/8921A controls, indicators, and connectors are shown in Figure 2-2 and described in Table 2-2. Features peculiar to one instrument are identified by model number, i.e., 8920A or 8921A.

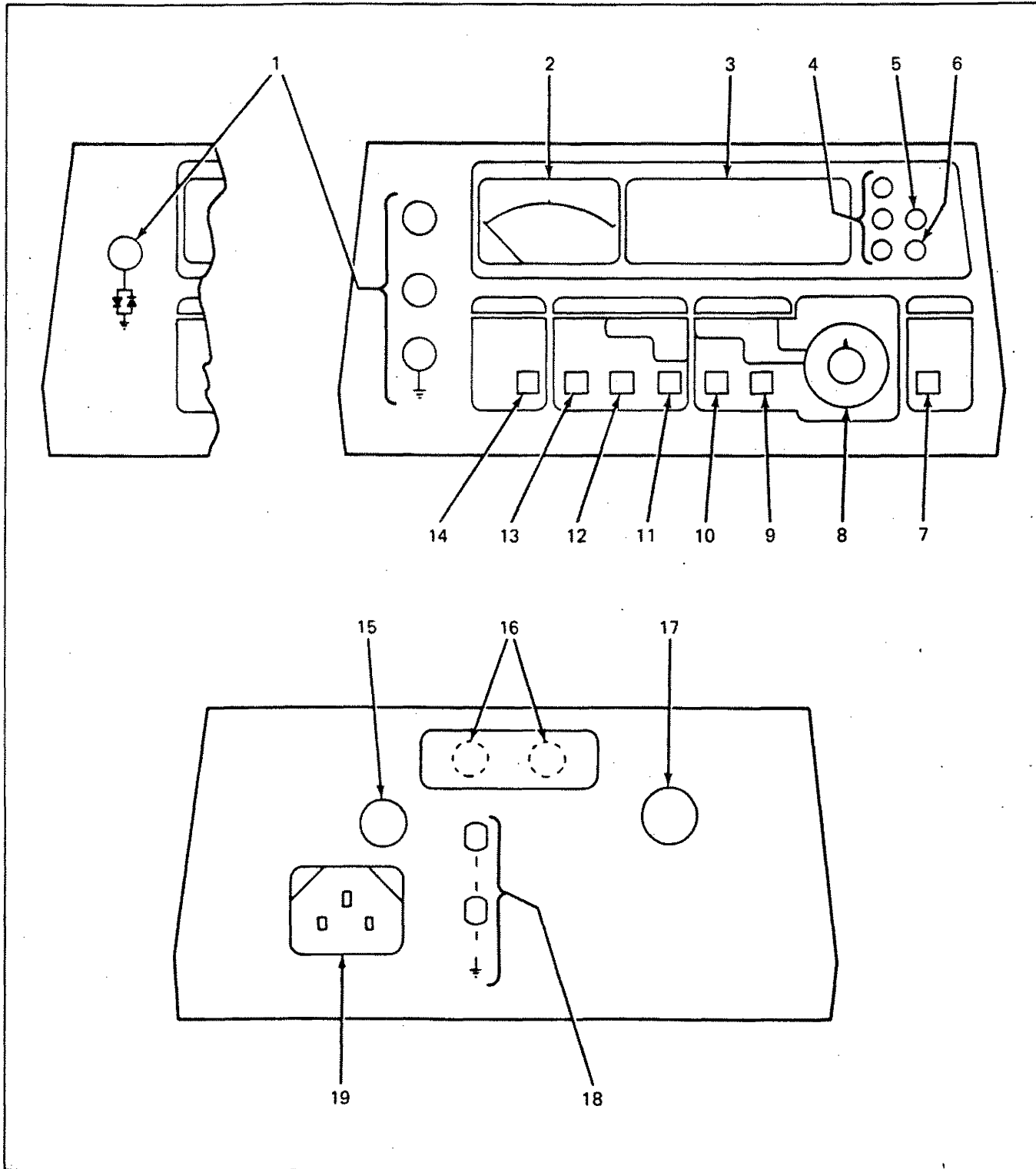

Figure 2-2. Controls, Indicators and Connectors

Table 2-2. Controls, Indicators and Connectors

REF NO.	NAME	FUNCTION
1	INPUT	8920A – A BNC input connector. The low side is isolated from power ground through a pair of parallel diodes. 8921A – Banana plugs provide high, low and power ground input connections. The HI and LO terminals are isolated from power ground. Maximum common mode voltage is 500V rms.
2	Analog Panel Meter	Uncalibrated panel meter provides analog tracking of input level; useful for peaking and nulling indications.
3	Digital Display	LED display provides a direct readout of the input signal level; includes decimal point and polarity.
4	Annunciators	LED's that light to indicate the selected measurement function V (volts), mV (millivolts) or dB (decibels).
5	2 MHz MAX.	An LED that lights to indicate that the instrument has autoranged into the 2 mV range. This range has a maximum frequency limit of 2 MHz.
6	RELATIVE REFERENCE	An LED that lights to indicate that the voltmeter is in the dB display mode and using a relative voltage reference.
7	POWER Switch	A push-push switch used to turn the instrument ON (in) and OFF (out).
8	dBm REFERENCE	Rotary switch used to manually select one-of-twelve reference impedances when the dBm and dB display modes are selected.
9	REL/dBm	A push-push switch used to select either the relative dB or the dBm display mode. When REL is depressed, the existing input level is used to establish a 0 dB reference. Subsequent level changes at the input are displayed in dB and referenced to the operator established 0 dB level. When dBm is selected, measurements are displayed in terms of dBm and the dBm REFERENCE setting.
10	dB VOLTS	A push-push switch used to select either the voltage (out) or dB (in) display mode.
11	STEP UP	A momentary pushbutton switch used to incrementally step the voltmeter to its next higher range. This switch is enabled only when the HOLD RANGE mode is selected.
12	HOLD/AUTO	A push-push switch used to select the manual (HOLD) or autorange (AUTO) mode. Selecting HOLD (in) enables manual upranging with the STEP UP switch. Selecting AUTO (out) enables the unit to autorange.
13	LO RANGE ENABLE	A push-push switch which, when depressed adds the 2 mV range to the autorange loop. When the switch is out the 2 mV range cannot be accessed.
14	AC + DC/AC	A push-push switch used to include (in) or delete (out) dc components as part of the input signal level.

Table 2-2. Controls, Indicators and Connectors (cont)

REF NO.	NAME	FUNCTION
15	F1	Line fuse, MDL 1/8A slow-blow.
16	DIGITAL OUTPUT/ LOG ANALOG OUTPUT	An output port reserved for use with the Logarithmic Output Option -004 (8920A only) or the IEEE-488 Interface. See Section 6 for details.
17	COUNTER OUTPUT	An output port reserved for use with the Counter Output Option -003. See Section 6 for details.
18	Linear Analog	A pair of banana jacks for Output accessing the dc linear analog output voltage (8920A only). This voltage is proportional to the Vrms input and is linearly scaled; 2V dc out equals a 2000 count readout. The scale repeats for each range.
19	Input Power Connector	A 3-prong line power connector for connecting the unit to line power.

2-12. OPERATING NOTES

2-13. The following paragraphs describe various conditions which you should be aware of before attempting to operate the 8920A/8921A.

2-14. Fuse Replacement

2-15. The Model 8920A/8921A is fuse protected from the power line. You can access the fuse by pressing and turning (CCW) the fuse cap located on the rear panel. When replacement is necessary use an MDL type 1/8 amp slo-blo fuse for all voltage configurations.

2-16. Display Indications

2-17. In addition to the standard digital readout, we have equipped the front panel display with a series of unique visual indicators. These include an overrange/overload indication, an underrange indication, and an analog meter. They function automatically to help you make error free measurements.

2-18. For example, when an input signal level exceeds the display limit for the selected range an overrange will occur. The display digits flash while the overrange is present. Selecting a higher range will eliminate the overrange condition.

2-19. Measurement accuracy is uncertain when the higher voltage ranges are used to measure low level signals. To alert you to this condition, the decimal point will flash when the input is too low for the selected range (less than 180 digits). You may eliminate this underrange indication by manually selecting a lower range or selecting autorange.

2-4

2-20. The uncalibrated analog panel meter complements the digital display by linearly tracking the input signal level. It provides a 0-to-100%-of-scale indication for the selected range. This feature will aid you in detecting the peak and null points of inputs having varying levels.

2-21. Measurement Connections

2-22. COAX OR OPEN LEADS

2-23. We recommend shielded or coax leads be used at the input for low level or high frequency measurements. Open leads (unshielded) may pick up interference from other sources causing errors at low levels. You may reduce high frequency errors by minimizing inductance and capacitance between the source and the 8920A/8921A input connector. Open test leads are otherwise adequate.

2-24. SAFETY CONSIDERATIONS

2-25. Under normal operating conditions the 8920A/8921A will not present a potential electrical shock hazard to the operator. However, careless use of input-lead connectors and/or adaptors may create a shock hazard.

WARNING

TO AVOID ELECTRICAL SHOCK HAZARD DO NOT USE EXPOSED LO INPUT LEAD CONNECTIONS ON THE MODEL 8921A UNLESS CONNECTED TO THE POWER GROUND. IF COAXIAL OR OTHER EXPOSED CONNECTIONS ARE USED FOR FLOATING MEASUREMENTS, A SHOCK HAZARD MAY EXIST.

2-26. The low input on the 8920A is connected to the power ground through a pair of diodes (see front panel connector). These diodes allow the low input terminal to float up to 400 mV rms (.6V peak). Their function is two fold; they provide isolation between input low and power ground, and they protect the operator from the possibility of hazardous voltages existing on the exposed low input connector.

2-27. At first glance, 400 mV of isolation does not appear significant. However, in most cases it provides enough isolation to prevent ground loop currents and, therefore, measurement errors due to ground loops.

2-28. When you connect the low input of the 8920A to a potential greater than 400 mV above power ground, the diode pair conducts and effectively clamps the input common mode voltage.

2-29. Under no circumstances should you attempt to defeat the function of the diodes. Specifically, the diodes should not be removed, the ground return on the power cord should not be floated, and an isolation transformer should not be used to power the 8920A. If the diodes are defeated, a shock hazard will exist at the low input connector when the low input lead is floated above 30 volts.

WARNING

**TO AVOID ELECTRICAL SHOCK HAZARD
DO NOT REMOVE OR OTHERWISE DEFEAT
THE INPUT DIODE PAIR.**

2-30. IMPEDANCE MATCHING

2-31. Two types of ac voltage measurements are typically made; those involving matched impedance systems and those where voltmeter loading is minimized (high impedance measurements) and no impedance matching occurs.

2-32. On the other hand, when matched impedance systems are measured the impedance should be determined as close as possible to the 8920A 8921A input, thereby minimizing input inductance and enhancing accuracy at high frequencies. This is accomplished by including the meter as an integral part of the circuit as shown in Figure 2-3A. Notice that the integrity of the 50Ω system is maintained by using a 50Ω power divider. An alternate solution is shown in Figure 2-3B. In this case, the source is alternately connected to the 8920A and the test circuit. This allows the source to be adjusted to a known level before being connected to the test circuit. Since both the meter and the test circuit are 50Ω loads the circuit integrity is maintained.

2-33. High impedance measurements are based on the assumption that the voltmeter's fixed 10 MΩ input resistance and low input capacitance will not appreciably load or otherwise affect the circuit being measured. If open leads are used (to hold down input capacitance) and the measurement frequency is low, this assumption holds true.

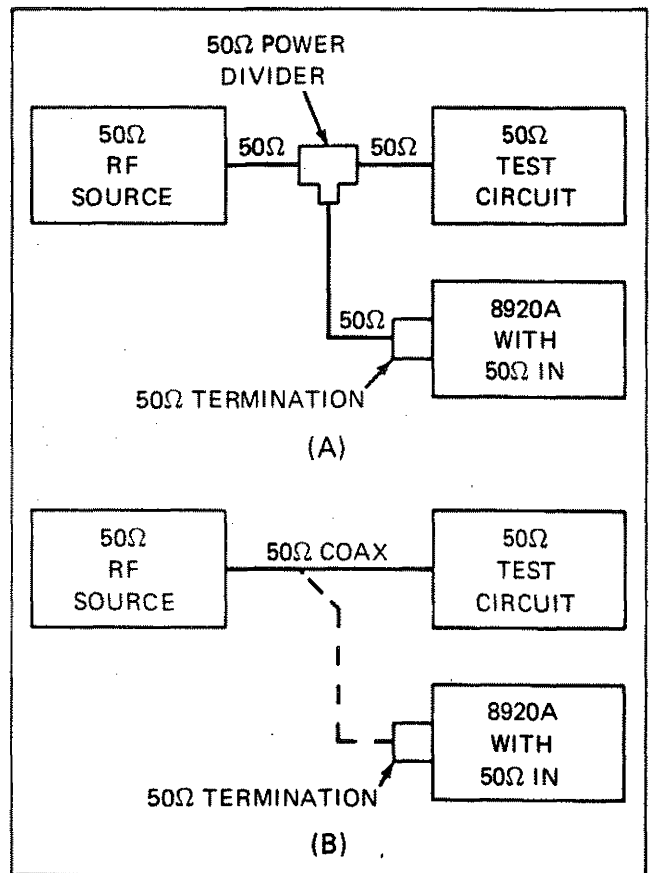

Figure 2-3. Matched Impedance Measurement Techniques

2-34. COMMON MODE VOLTAGE MEASUREMENTS

2-35. The Model 8921A is equipped with isolated input connections and can accommodate common mode (floating) voltages as high as 500V rms. Higher common mode voltages may cause instrument failure. The 8920A will accommodate common mode voltages as high as 600 mV peak, usually enough to open ground loops in the power connections.

2-36. Even though the 8921A is capable of making common mode measurements it is not a true balanced input voltmeter. It does not have equal or balanced impedances between the high and ground, and the low and ground input terminals. On the 8921A the LO-to-ground input capacitance is not matched with the high-to-ground capacitance. Since the majority of voltmeter applications do not require balanced inputs, this will rarely present a problem.

2-37. Input Signal Considerations

2-38. The 8920A/8921A is a true rms voltmeter and, as such, is subject to input conditions not encountered with the ordinary average-reading ac voltmeter. Of these, the two most important are crest factor and input coupling.

2-39. CREST FACTOR

2-40. Crest factor is the ratio of the peak voltage to the rms voltage of a waveform with the dc component removed. The 8920A/8921A will accommodate signals having crest factors of 7 at full-scale, increasing for down-scale readings. Use the following formula to calculate below full-scale crest factors capability:

$$\text{Crest Factor: } \frac{7 \times \text{Range}}{\text{Input}}$$

2-41. INPUT COUPLING, AC DC

2-42. The 8920A/8921A are equipped with a FUNCTION switch which allows you to select either AC or AC+DC coupling. When the switch is out, AC coupling is selected. In this function the dc component is removed from the input signal and is not measured or displayed. Depressing the FUNCTION switch selects AC+DC coupling. This function allows the 8920A/8921A to measure and display the true rms value for the total input signal; ac components and dc components. You should always consider the dc component when power dissipation is being determined.

2-43. Range Selection

2-44. Seven voltage ranges and what appears to be a single dB range spanning 132 dB are provided in each instrument. Range selection is normally accomplished automatically. Override switches (step up), however, allow you to interrupt the autorange function and manually increment the range.

2-45. We designed the autorange function to optimize the display reading for a given input. Each reading is displayed complete with decimal point and units annunciator. Since range selection is essentially automatic, the individual ranges are not directly defined for the operator. Instead, underrange (flashing decimal point) and overrange (flashing digits) indications are provided to indicate when a range change is necessary.

2-46. AUTORANGE

2-47. The proper measurement range is automatically selected when the HOLD AUTO switch is in the AUTO (out) position. If the LO RANGE ENABLE switch is depressed, the meter will autorange (up and down) from the 2 mV range to the 700V range. When LO RANGE ENABLE is not depressed the 2 mV range is deleted from the available ranges.

2-6

NOTE

For the 2 mV range to be selected, LO RANGE ENABLE must be depressed and the input signal level must be less than 2 mV. Downranging occurs at 180 digits and upranging occurs at 2000 digits.

2-48. MANUAL

2-49. Manual range selection is accomplished by selecting a range using the autorange mode and then depressing the HOLD AUTO switch. The meter will stay in that range regardless of input level changes. If the range becomes invalid for a given input level, an overrange or underrange indication will flash. If an underrange is indicated select autorange (AUTO), and after the proper range is selected press HOLD. For overrange conditions momentarily press the STEP UP switch once for each desired range increment. Holding the switch in will increment the meter to the 700V range. Select autorange (AUTO) to downrange.

2-50. Voltage Display Mode

2-51. The 8920A/8921A will display a voltage input in one of two measurement units, volts or dB. To display the input voltage in units of volts, you must set the dB VOLTS switch to VOLTS. The instrument will now display all input in units of volts or millivolts, as indicated by the front panel annunciators (V), (mV).

2-52. A couple of points of interest about the volts display mode are as follows: one, if the input is completely unknown, allow the autoranging circuit to select the appropriate range. Two, the selection of the volts display mode will not affect any previous reference established in the dB display mode (see following paragraphs for additional information about establishing a dB reference).

2-53. dB Display Mode

2-54. When the instrument is in its dB display mode all voltage inputs are referenced to a selected level, and displayed as deviations (in dB) above or below that level. If you wish to display the input voltage in dB units, you need only to set the dB VOLTS switch to dB. The instrument's front panel dB annunciator will now light, indicating to you that the display is presenting a measurement in dB units.

2-55. Like the voltage display mode, there are points about the dB display mode of which you should be aware. The instrument references all inputs to a selected level, therefore before a meaningful measurement in dB units can be made the desired reference level (0 dB) must be established, see RELATIVE REFERENCE Selection and dBm REFERENCE.

2-56. dBm Measurements

2-57. Measurements made to a fixed 1 milliwatt reference are defined as dBm. The 1 milliwatt reference is generally assumed, as indicated by m. However, the system impedance must be specified for a particular measurement. Once the impedance is known and selected, the instrument will display its measurements in dBm.

2-58. The 8920A/8921A is equipped with a rotary switch called dBm REFERENCE (Ω). By setting the switch to 1-of-12 possible standard reference impedances (50 Ω , 75 Ω , 93 Ω , 110 Ω , 124 Ω , 135 Ω , 150 Ω , 300 Ω , 600 Ω , 900 Ω , 1000 Ω , and 1200 Ω) you establish that impedance as a reference. When the system impedance and the reference are the same, the 8920A, 8921A manipulates subsequent measurements to readout in terms of dBm.

NOTE

If the 1000 ohm reference impedance is selected ("dBV" on the rotary switch) the 0 dB point will correspond to 1V.

2-59. dBm REFERENCE SELECTION

2-60. Use the following procedure to select a reference impedance and enable the dBm display mode:

1. Depress the dB/VOLTS switch (in).
2. Release the REL/dBm switch (out).
3. Set the dBm REFERENCE (Ω) switch to correspond with the system impedance

NOTE

The dBm REFERENCE switch does not affect the fixed 10 M Ω input impedance of the 8920A/8921A. All impedance matching terminations must be added by the operator.

2-61. RELATIVE MEASUREMENTS (REL)

2-62. This feature allows you to make any voltage input a "0 dB point" to which all other voltage inputs may be referenced. For measurements at a single test point, merely press the dB switch, then the REL switch and watch the dB change as you make adjustments and change components.

2-63. A typical application for the dB measurement mode is shown in Figure 2-4. The relative reference (0 dB) has been established at TP2. Subsequent dB measurements at TP1, TP3, TP4 and TP5 are displayed (in dB) as shown.

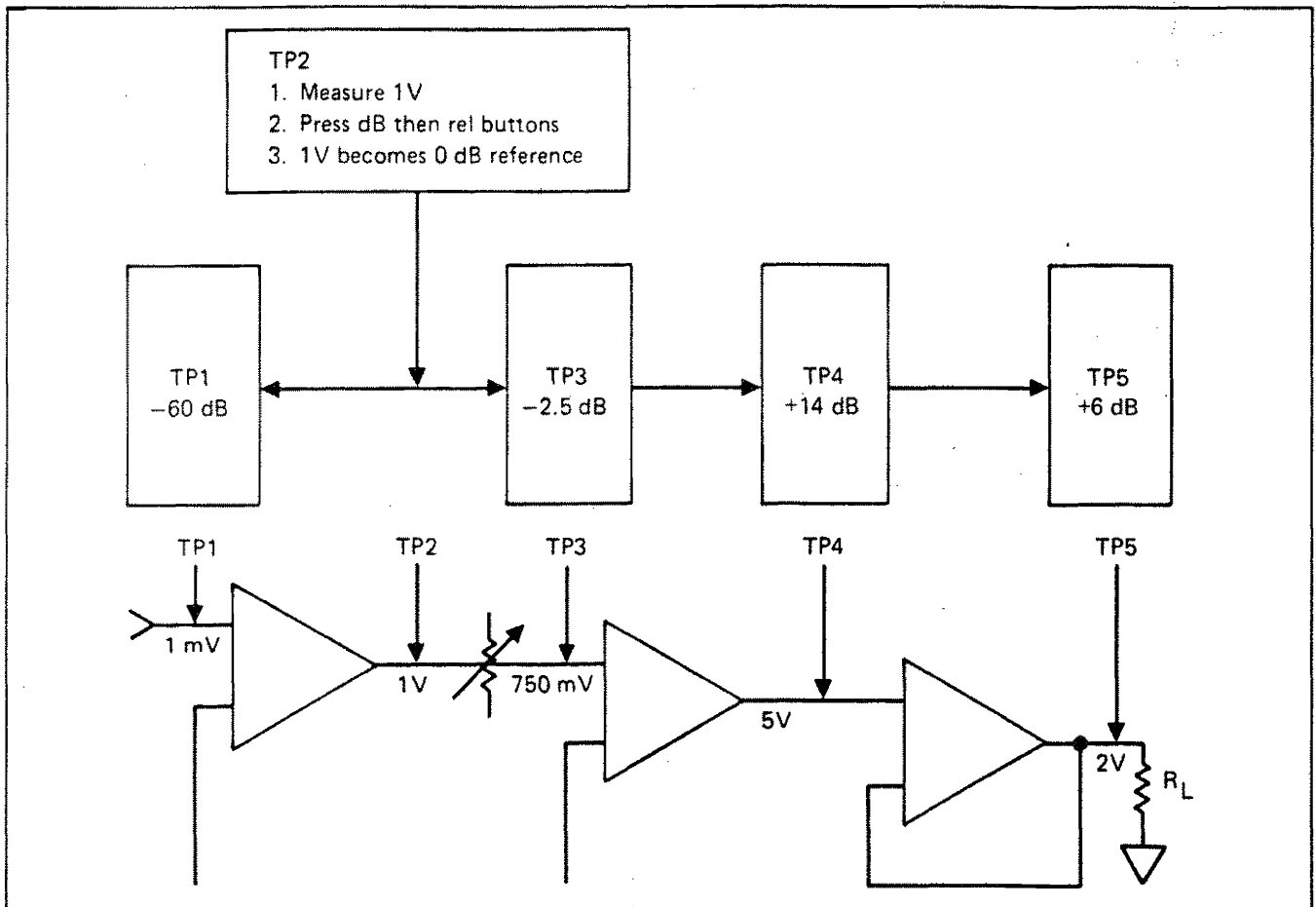

Figure 2-4. Typical Relative dB Measurements

2-64. RELATIVE REFERENCE SELECTION

2-65. Use the following procedure to enable the relative (REL) display mode and select a relative (0 dB) reference.

1. Connect the reference source to the 8920A/8921A input terminals. If desired, measure and adjust the reference supply voltage level.
2. Select the autorange mode (AUTO).
3. Release the REL/dBm switch (out).
4. Depress the dB/VOLTS switch (in).
5. With the reference level still connected to the input terminals, depress the REL switch. The display should now read 0 dB and the RELATIVE REFERENCE annunciator should be lit.

2-66. OTHER dBm REFERENCES

2-67. When a dBm reference other than those given on the dBm REFERENCE switch is required, use the following procedure to establish the reference:

1. Define the reference impedance (R) and calculate V using the following formula:

$$V = \sqrt{0.001 \times R}$$

2. Apply a reference voltage such that the 8920A/8921A displays "V" with the dB VOLTS switch in the VOLTS position.
3. Depress the dB VOLTS switch (in).
4. Depress the REL dBm switch (in). This establishes the voltage (V) as the 0 dB reference level. Therefore, subsequent dB measurements will be equivalent to dBm measurements as long as the system impedance R is maintained.

NOTE

This reference will hold as long as the REL/dBm switch is not released and the instrument is turned on.

2-68. Linear Analog Output

2-69. We have provided a pair of banana jacks on the rear of the 8920A for accessing a linear dc analog output signal. This signal is proportional to the applied input signal and is linearly scaled; a 2V dc output is equal to 2000 counts on the display. The scale is repeated for each range so that a continuously increasing input spanning the entire 180 μ V to 700V capability of the 8920A results in a seven cycle sawtooth output. Output accuracy is 1% relative to the front panel reading. The output signal is buffered, and is suitable for driving an external analog meter, recorder, plotter, scope, etc.

2-70. OPERATION

2-71. With reference to the preceding paragraphs use the following procedure to turn-on and operate the Model 8920A/8921A (refer to Section 6 for option and accessory information):

1. Connect the 8920A/8921A to line power.
2. Set the front panel POWER switch to ON (in). The front panel display should light.
3. Select the appropriate input leads and connect them to the meter's input terminals. Add terminations as close as possible to the input connectors, if impedance matching is required.
4. Select input coupling by setting the FUNCTION switch to AC (out) or AC+DC (in), as desired.
5. Select the desired range. Use automatic or manual method, as desired.
6. Set the DISPLAY switches to select the desired measurement mode: volts, dB, or dBm. If dB is selected, establish a 0 dB reference.
7. Observing safety considerations, connect the test leads to the measurement points. The results are displayed on the 8920A/8921A readout.

Section 3

Theory of Operation

3-1. INTRODUCTION

3-2. The information we have compiled in this section is the theory of operation of the 8920A and the 8921A True RMS Voltmeters. The theory has been divided into two major headings; Overall Functional Description and Detailed Block Diagram Description. To gain maximum benefit from this section, we recommend that you read each paragraph in the order presented while referring to the associated figure or the appropriate schematic in Section 8.

3-3. OVERALL FUNCTIONAL DESCRIPTION

3-4. As you can see in Figure 3-1, the circuitry of the 8920A and 8921A can be divided into two sections;

analog and digital. An overall functional description of these two sections is presented in the following paragraphs.

3-5. Analog Circuitry

3-6. The analog section comprises the largest portion of the 8920A and 8921A circuitry. As shown in Figure 3-1, this section is broken down into the following areas; the Signal Conditioner, the RMS Converter and the Power Supply.

3-7. Referring to Figure 3-2, you can see that the signal being measured by either the 8920A or 8921A can be coupled to the Signal Conditioner in one of two ways (AC or AC+DC). When you place the FUNCTION switch on the front panel to the AC position all input

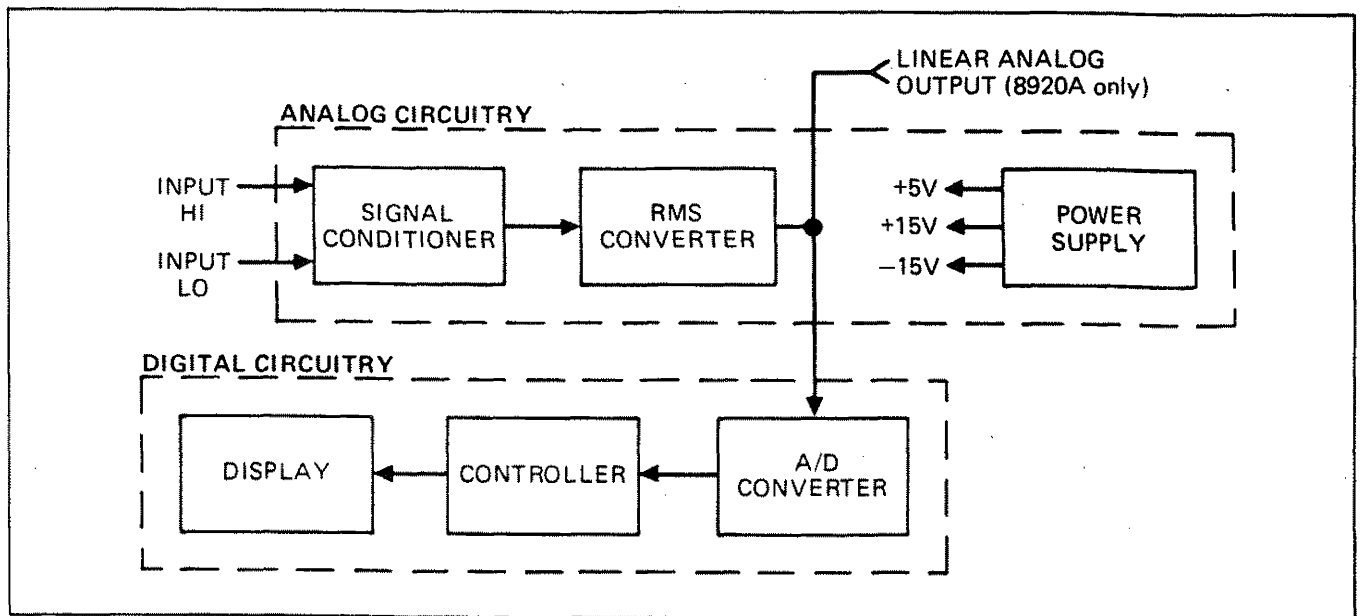

Figure 3-1. Overall Block Diagram

signals are capacitively coupled; when the AC+DC position is selected the input signal is dc, or directly coupled. This feature contributes to the measurement accuracy when dc components are present in the input signal.

3-8. The Signal Conditioner insures that the varying levels on instrument's input voltages are properly scaled before being applied to the RMS Converter. The RMS Converter works on a thermal sensing principle. Basically, it operates by balancing the heating power of a dc feedback signal to the heating power of the ac input signal. When the two are equal, the circuit is in equilibrium and the dc output voltage applied to the A/D Converter is directly representative of the true rms value of the ac input signal. The dc output of the RMS Converter is also applied to the LINEAR ANALOG OUTPUT terminals on the rear panel of the 8920A, as well as the analog meter on the front panel of the 8920A and 8921A.

3-9. The last analog circuit we discuss in this section is the Power Supply. This circuit provides three regulated power supplies (+5V, +15V and -15V) to operate the instrument.

3-10. Digital Circuitry

3-11. The digital circuitry comprises the A/D Converter, the Controller and the Display. Together these circuits develop a digital representation of the rms value of the input signal, produce the commands that set the range and function of the instrument and finally display the input value.

3-12. The dc output of the RMS Converter is translated to a digital representation by the A/D Converter. The digital representation is then processed by the controller to obtain a BCD output which is proportional to the desired display mode (VOLTS, dB, dBm, REL). The BCD output is decoded and applied to the display for visual inspection.

3-13. DETAILED BLOCK DIAGRAM DESCRIPTION

3-14. In the following paragraphs we discuss, in detail, the individual functions within the major areas of circuitry in the 8920A and 8921A. Each major circuit area is described in detail in Figure 3-2. The following paragraphs describe the functioning of these subordinate areas. The description for each circuit is keyed to its own functional block diagram, or to the schematics in Section 8.

3-15. Signal Conditioner

3-16. The Signal Conditioner utilizes an Input Attenuator, two amplifiers (Amp A and B) and the

Intermediate Attenuator. As shown in Figure 3-3, these circuits are used to scale the varying voltage levels applied to the instrument so that the input to the RMS Converter is always between 0.09V rms and 1V rms. The diagram in Figure 3-3, illustrates the configuration of the circuitry within the Signal Conditioner. The Controller, through a range decoder network, issues commands which select the appropriate division factor in the attenuators and the correct multiplication factor for Amplifier A. Table 3-1, lists each operating range and the corresponding division and multiplication factors for the attenuators and amplifier (note that Amplifier B has a fixed gain of x11). The last column lists the components FETs and relays, that conduct to establish gain configuration of the circuits (see the schematics for details on components).

3-17. RMS Converter

3-18. The 8920A and 8921A use a thermal rms converter circuit which supplies a dc output voltage proportional to the rms value of the ac input. The thermal sensor is a pair of resistor-transistor elements thermally isolated from each other and the case (see Figure 3-4). The ac input signal (V_{ac} from Amp B) produces a temperature change in the RMS Sensor's input resistor which is sensed by the associated transistor and causes a voltage change at the negative input of the Integrator. Feedback, through the Square Root Amplifier, provides a dc voltage to the RMS Sensor's output resistor such that a similar temperature rise occurs in the output resistor. The sensor gain is not constant with changes in input amplitude. These changes in gain are compensated for by the square root amplifier, maintaining constant response time with changes in level.

3-19. The rms sensor is susceptible to damage from overvoltage inputs. During an overload condition, the protection circuit will clamp the output of Amplifier B to prevent damage to the sensor. Overload conditions would result during turn on, turn off, or any time the rms value of the applied input exceeds the operating range of the sensor.

3-20. A/D Converter

3-21. A dual-slope integration technique is used in the Model 8920A/8921A A/D Converter. This method applies the unknown voltage to a capacitor and allows the capacitor to charge for a specific time interval. At the end of this interval, the unknown voltage will be removed. (The charge on the capacitor at this time will be proportional to the level of the unknown voltage.) Then a known voltage of opposite polarity is applied to the capacitor and clock pulses are counted while the capacitor discharges. When the capacitor has reached its original charge point, the number of clock pulses counted is a digital construction of the analog voltage input to the A/D Converter.

Figure 3-2: Detailed Block Diagram

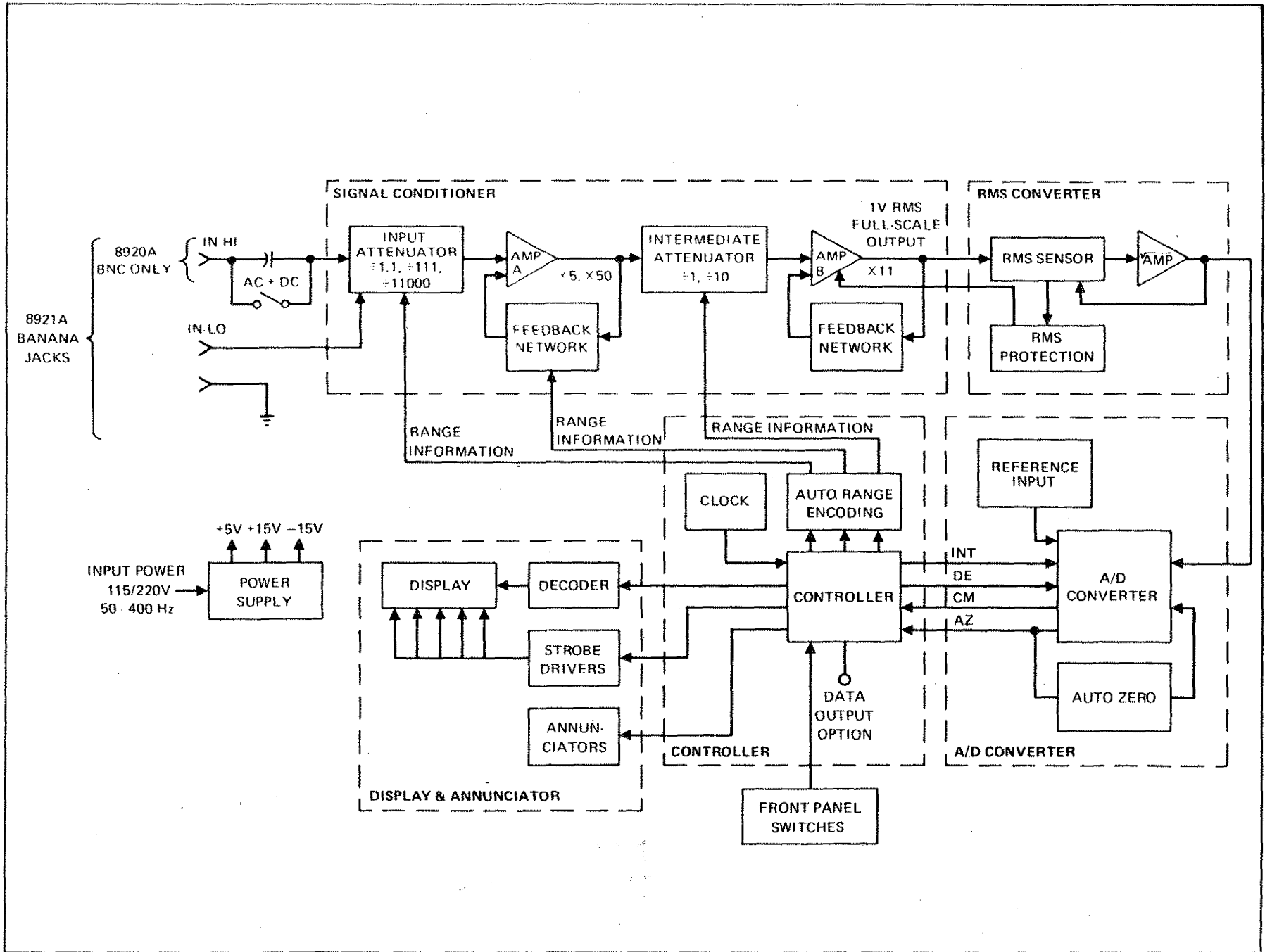

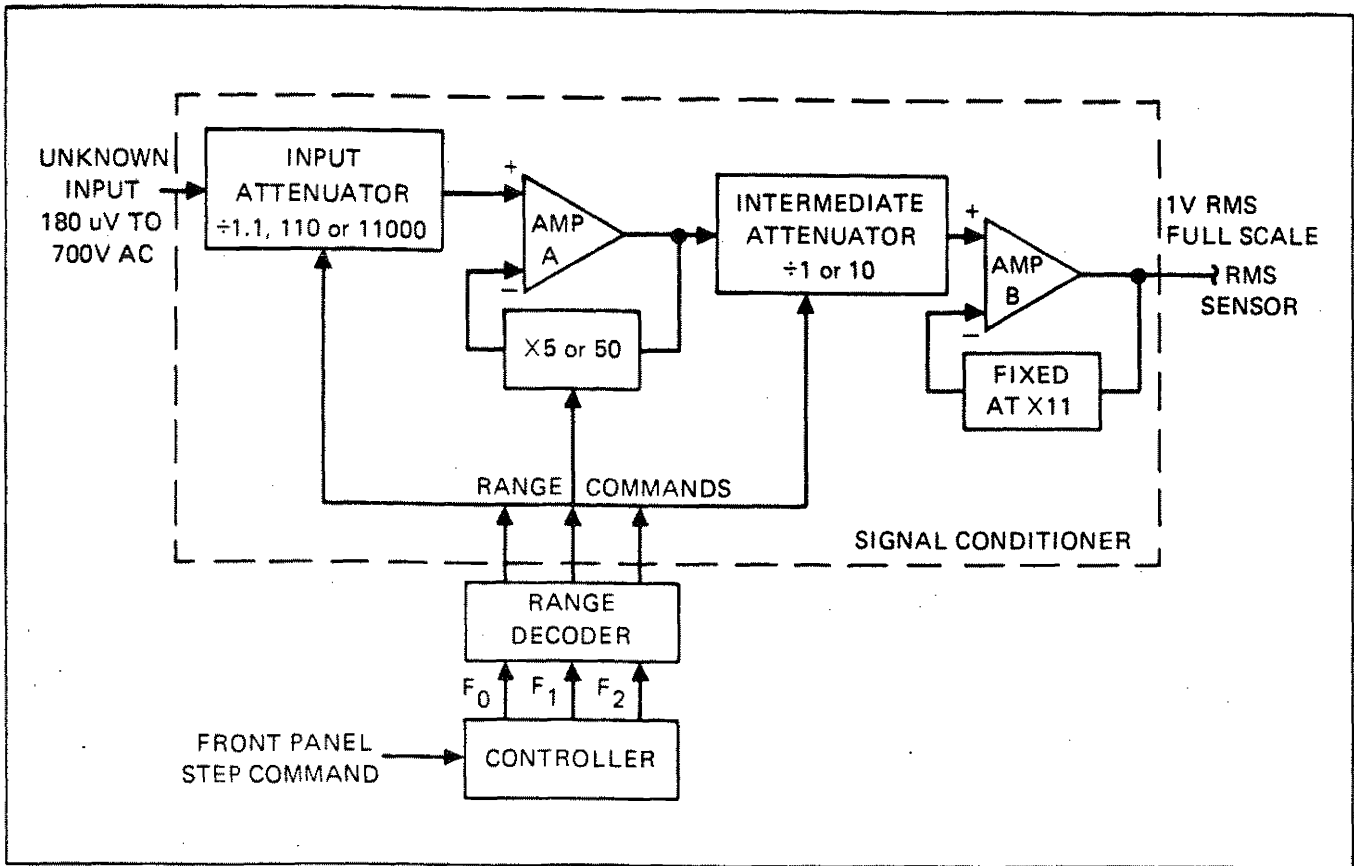

Figure 3-3. Signal Conditioner

Table 3-1. Signal Conditioner Gain Configuration

RANGE	INPUT ATTENUATOR	AMP A	INTERMEDIATE ATTENUATOR	*CONDUCTING COMPONENTS
2 mV	÷1.1	X50	÷1	K1, Q6, Q28, Q30, Q32
20 mV	÷1.1	X5	÷1	K1, Q6, Q29, Q32
200 mV	÷1.1	X5	÷10	K1, Q6, Q29, Q31
2V	÷110	X5	÷1	K2, Q3, Q5, Q29, Q32
20V	÷110	X5	÷10	K2, Q3, Q5, Q29, Q31
200V	÷11,000	X5	÷1	K2, Q4, Q5, Q29, Q32
700V	÷11,000	X5	÷10	K2, Q4, Q5, Q29, Q31

* Refer to the schematics in Section 8.

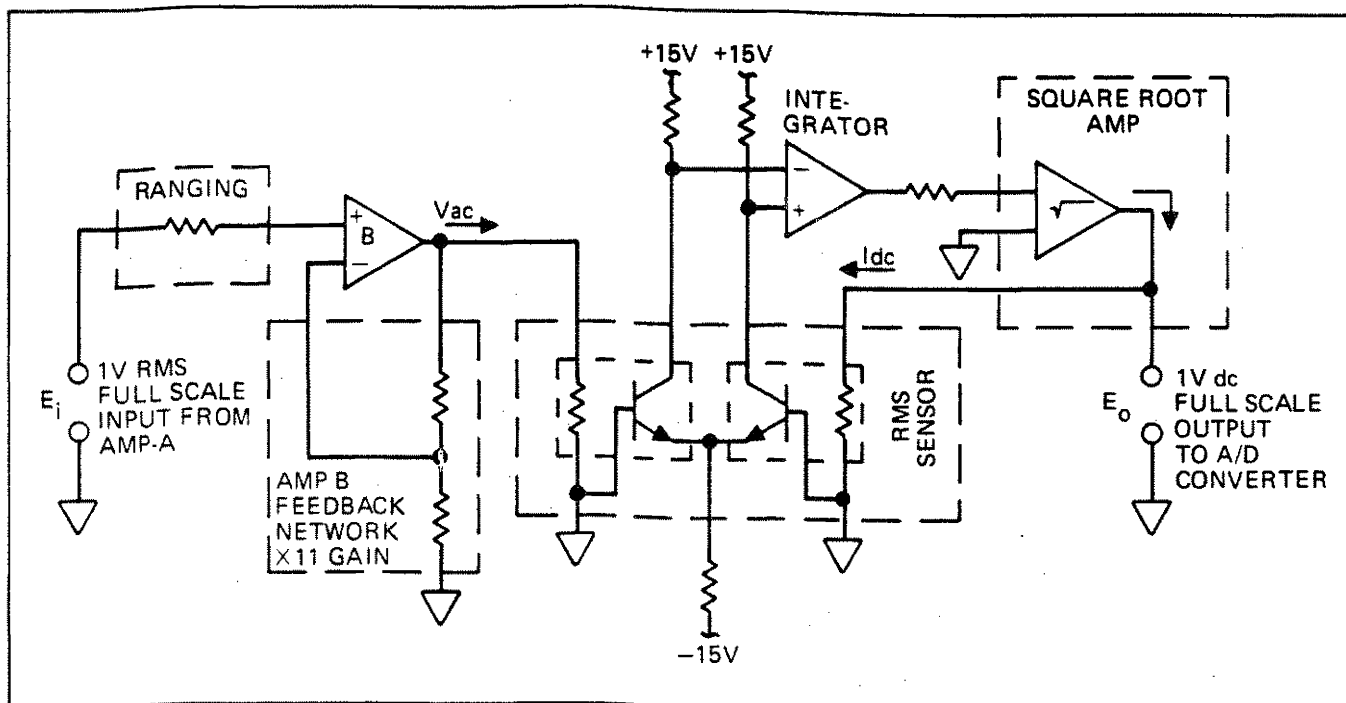

Figure 3-4. RMS Converter

3-22. For the following discussion refer to Figure 3-5, the A/D Converter Simplified Schematic and Timing Diagram and Figure 3-6, Controller Timing (A/D Converter).

3-23. At the beginning of the measurement cycle, INT goes high and the dc output of the rms sensor is applied to the A/D integrator for 100 msec. C203 charges up from the auto zero level at a rate proportional to the applied input voltage and the comparator's output, CM, is driven low. At the end of the 100 msec integrate period, DE (-) goes high applying the reference voltage to the integrator. The integrator then discharges at a rate which is constant for all on scale inputs and the controller begins counting clock pulses. When C203 has discharged to the auto zero level, CM will go high, the controller will stop counting and the reading is displayed. AZI then begins, allowing the A/D Converter circuitry to settle before the next read cycle. If CM has not occurred before the end of the 200 msec maximum DE (-) period, the input will have exceeded the present range. In this case, the DE period will continue until either CM or the end of the 100 msec AZI occurs.

3-24. Controller

3-25. The Controller is a custom LSI that controls autoranging, the A/D Converter and the Display and Annunciators. In addition, the Controller can count in a non-linear (dB) scale and display its count in dB units. The A/D Converter has already been described and the

Display and Annunciators will be described immediately after this section on the Controller. A summarized description of each input and output pin used on the Controller is given in Table 3-2 and shown in Figure 3-7.

3-26. AUTORANGING

3-27. Autoranging is the automatic selection of the instrument's range by the Controller. With the low range enabled, the instrument may range through seven voltage ranges from 2 mV to 700V rms. Autoranging also applies in the dB modes but gives the effect of a single range spanning 132 dB. By coding the logic levels on the three lines, F0, F1, and F2, the Controller selects a range (see Table 3-3, Output Range Codes) by setting up the circuit conditions of the input and intermediate attenuators and amplifier A that are necessary for signal conditioning in that range. (See Table 3-1, Signal Conditioner Gain Configuration.) If the Controller senses that the input is above or below the selected range (see Table 3-4, Over Underload Conditions), it shifts up or down one range (depending upon the direction sensed) and halves its cycle time. The Controller blanks the display and checks if the input to the instrument is now in range or if a further change in range is necessary. When the proper range is found, display blanking is removed and the cycle time returns to normal. Use of the HOLD RANGE control will command the Controller to remain at the present range (see Table 3-5, Input Range Codes) via command input line D, E, and F. Use of the STEP UP RANGE control will increment the instrument one range.

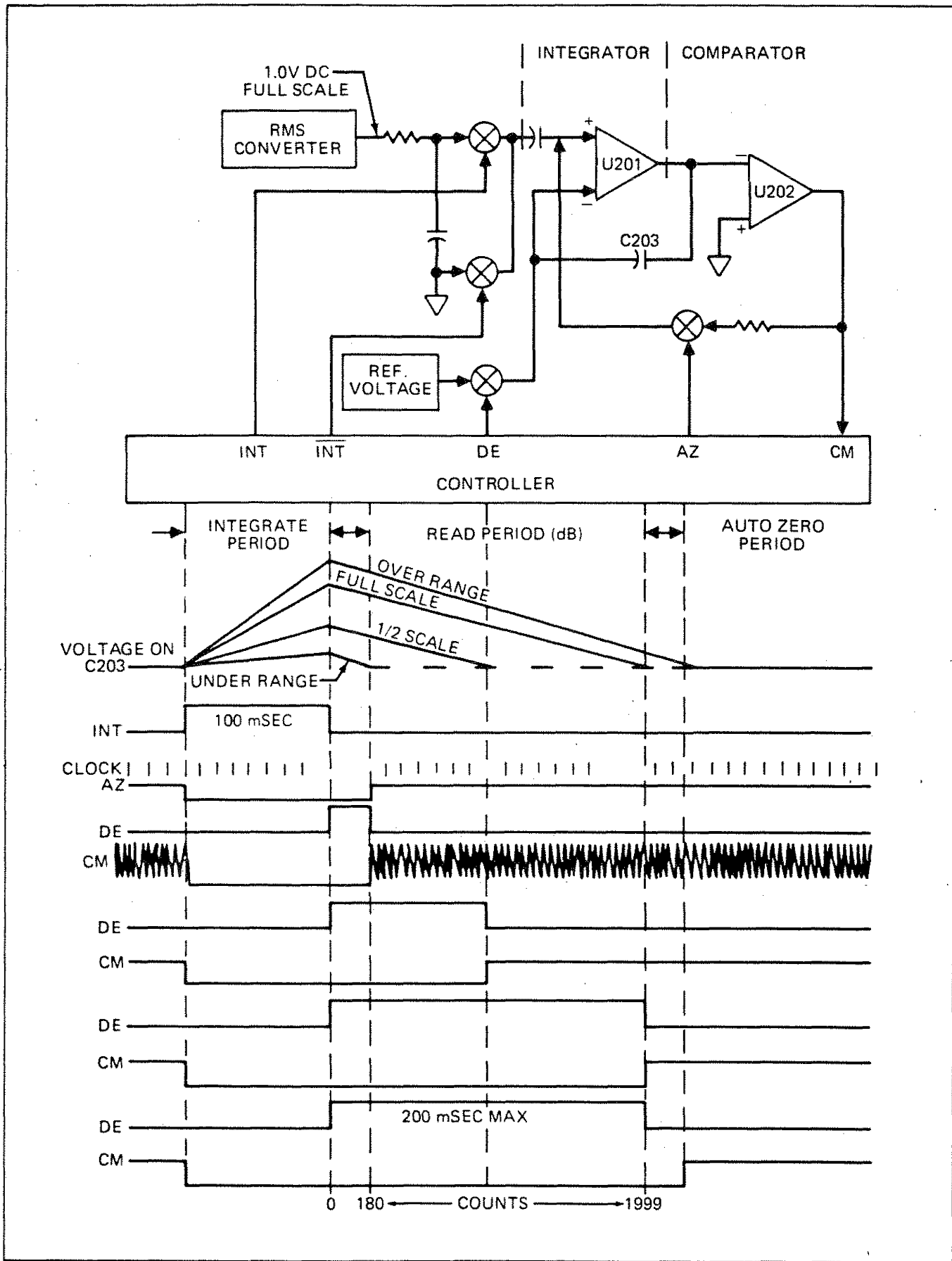

Figure 3-5. A/D Converter, Simplified Schematic and Timing

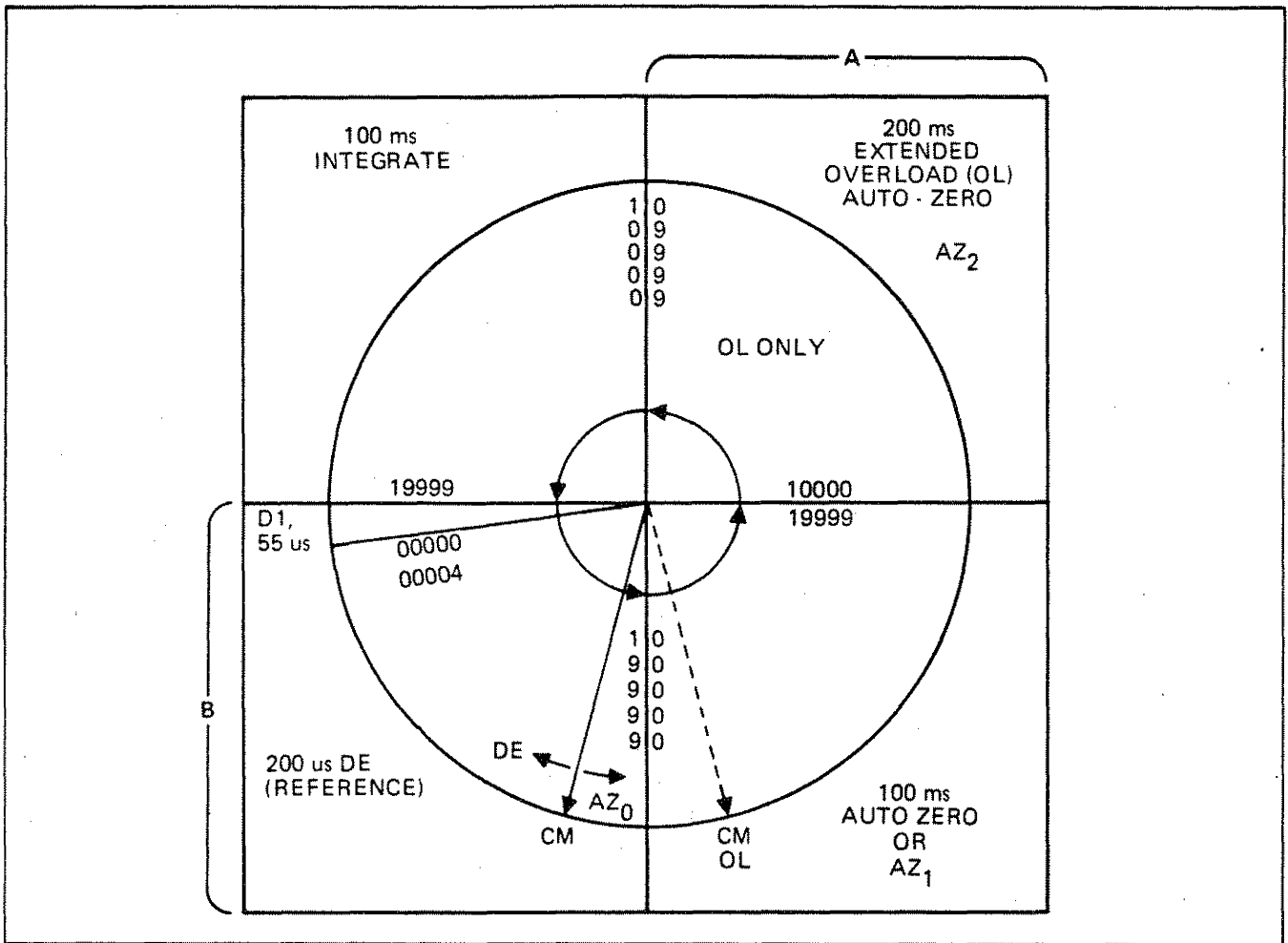

Figure 3-6. Controller Timing (A/D Converter)

Table 3-2. Controller Summary

INPUT/OUTPUT	PIN #	PIN NAME	PIN DESCRIPTION
Input	1.	V _{SS}	+5V supply
Input	2.	CM	Compare signal from A/D Converter.
Input	3.	CL ₁	External Oscillator input.
Input	4.	CL ₂	400 kHz crystal input for internal oscillator.
Output	5.	\overline{RG}	Negative going pulse in the middle of each strobe. Insures strobed data for DOU is valid.
Output	6-10, 12-14.	ST ₀ -ST ₇	Eight strobes that indicate which LED is to be enabled and accept the data on lines W, X, Y and Z.
Input	11.	RD	Impedance reference selection line, in dB.
Output	15-17.	F ₀ -F ₂	Encoded range lines, F ₀ = MSB, F ₂ = LSB, code equals range # + 1, voltage swings from; -15 to 0V.
Input	18.	β	Strobe input on this pin determines the lower range limit.
Input	19.	α	Strobe input on this pin determines the upper range limit.
Output	20.	DP	Enables display decimal point.
Input	21.	V _{DD}	Ground, 0V supply.

Table 3-2. Controller Summary (cont)

INPUT/OUTPUT	PIN #	PIN NAME	PIN DESCRIPTION
Output	22.	BZ	Indicates new data is ready for DOU, occurs after CM, one strobe raster long.
Input	23-25.	F, E & D	Enables controller ranging, see Table 3-5.
Output	26-29.	W, X, Y & Z	BCD data, W = MSB, Z = LSB, TTL compatible.
Output	30.	$\overline{\text{BLK}}$	Drives blanking input on display decoder driver, TTL compatible.
Input	31.	$\overline{\text{K}}$	700V range overload enable.
Input	32.	VGG	-15V supply.
Input	33.	$\overline{\text{J}}$	Enables 3½ or 4½ digit display in linear mode and determines (in combination with RD) the fixed reference in dB mode.
Input	34.	T ₁	Test (not used).
Input	35.	dB	Enables dB display mode.
Output	36.	$\overline{\text{INT}}$	Enables not integrate period of A/D Converter.
Output	37.	INT	Enables integrate period of A/D Converter.
Output	38.	AZ	Enables auto zero period of A/D Converter.
Output	39.	DE (-R)	Enables integrate reference period for positive input of A/D Converter.
Output	40.	DE (+R)	Enables integrate reference period for negative input of A/D Converter (not used).

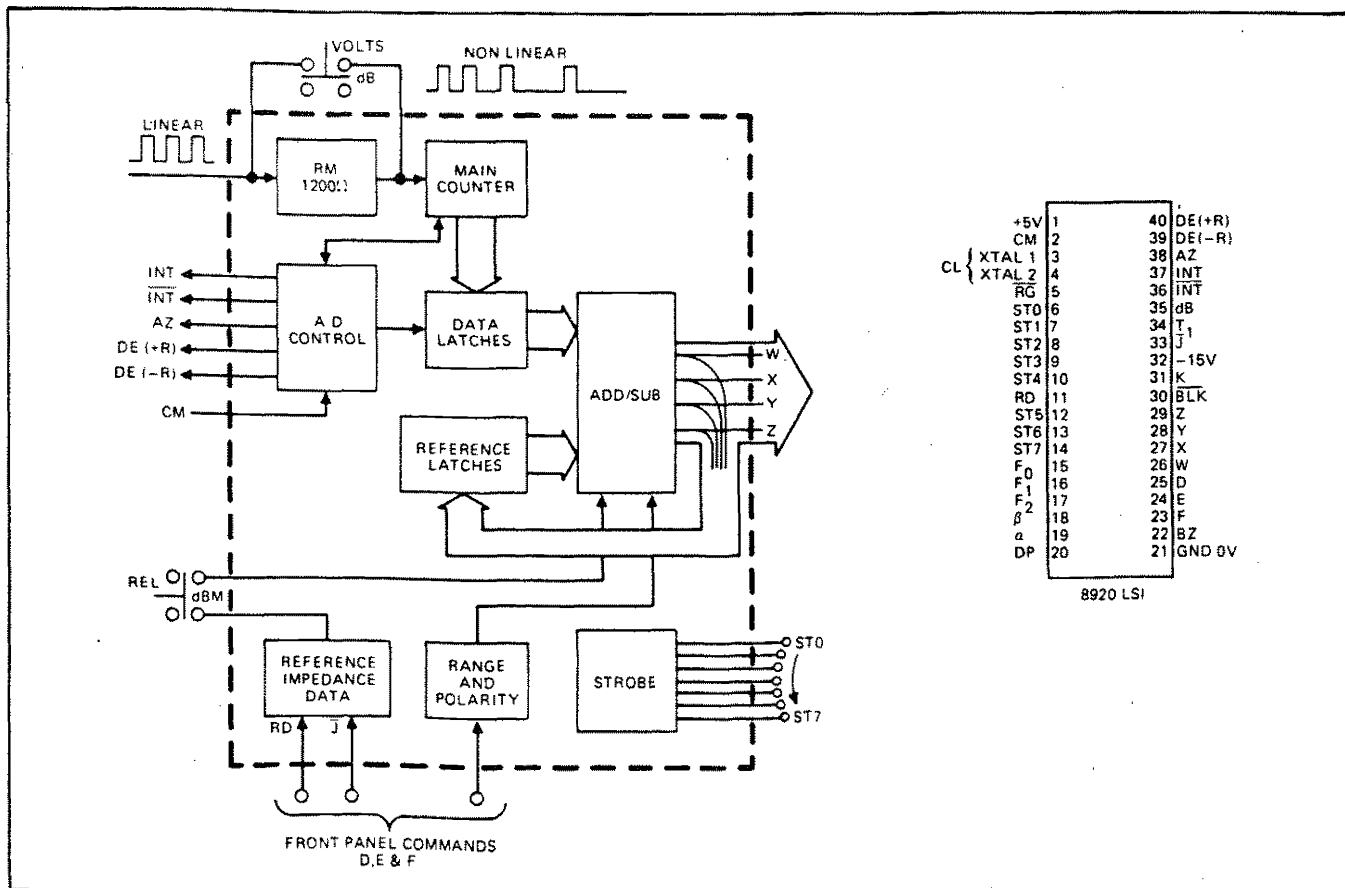

Figure 3-7. Controller Functions

Table 3-3. Output Range Codes

RANGE	DATA LINES		
	F ₀	F ₁	F ₂
2 mV	0	0	1
20 mV	0	1	0
200 mV	0	1	1
2V	1	0	0
20V	1	0	1
200V	1	1	0
700V	1	1	1

Table 3-4. Over/Underload Conditions

	LINEAR	dB*
Overload: except for 700 700V range:	>1999 β	25.30 (20V range)
	>700 α	56.10
Underload: minimum input for accurate dB conversion	<180	4.30 (20V range)
	132	1.60 (20V range)

*dB calculations are based on a 1200 ohm reference impedance and 20V range. The calculation is then corrected for the proper range and the selected impedance by the addition of the appropriate constant, which may be calculated from the following equation:
 $20 \log \sqrt{1.2 - 20 \log \sqrt{0.001R + N}} + N (20)$.
 Where N = number of ranges above or below the 20V range, i.e., 2 mV range N = X4

Table 3-5. Input Range Codes

COMMAND LINES			8920 CONTROLLER FUNCTION
D	E	F	
0	0	1	Auto range fast range cycle
1	0	0	Hold present range (overridden by α & β)
1	1	0	Range up at CM time (overridden α & β)

3-28. The 2 mV range will not be selected by autoranging unless the LO RANGE ENABLE switch is selected. If the low range is enabled and the instrument enters the 2 mV range, the 2 MHz MAX annunciator will illuminate to remind the user of instrument limitations.

3-29. COMPUTATIONS

3-30. The Controller is able to count (compute) in two modes, linear or non-linear. The following paragraphs will explain how the Controller obtains its linear (volts) or non-linear (dB) readings.

3-31. VOLTAGE COMPUTATIONS

3-32. To make a voltage measurement the Controller must linearly count clock pulses for a time determined by the A/D Converter. Referring to Figure 3-7, you can see that when the dB/VOLTS switch is placed in its up (out) position the rate multiplier (RM) will be shunted and the main counter will count the number of clock pulses exactly as they occur (linear). As soon as the integrator in the A/D Converter reaches the auto-zero point, CM will go high, commanding the main counter to stop counting and simultaneously shifting its count to the data latches. What is now held in the data latches is a count of clock pulses, in bcd format, that is proportional to the true rms value of the signal being measured. The bcd data is then shifted out of the controller, to a seven-segment decoder on four lines: W, X, Y and Z.

3-33. dB COMPUTATIONS

3-34. If the dB/VOLTS switch is in the dB position, a non-linear count of the clock pulses is enabled. The binary rate multiplier (RM) passes only a fraction of the clock pulses on to the Controller's main counter (see the illustrated input to the main counter on Figure 3-7). This count approximates the logarithmic curve of the dB scale and, like the VOLTS mode, is stored in the data latches.

3-35. dBm REFERENCE

3-36. Don't let the m confuse you, it simply means that the power level, as measured in "dB Computations", is referenced to 1 mW. In other words, when the instrument reads 0 dB the system being measured will be dissipating 1 mW of power. The following will explain how the controller obtains a measurement of power referenced to 1 mW (dBm).

3-37. In order for the controller to obtain a measurement in dBm parameters, the appropriate reference impedance must be used. A 1200 ohm reference impedance is assumed by the RM. Therefore, if any other reference is desired an appropriate constant must be added or subtracted from the count. The dBm REFERENCE rotary switch connects one of the eight strobes to RD and J. The controller responds by sending the appropriate constant to its ADD/SUB.

3-38. Referring to Figure 3-7, let's assume that a 600 ohm reference impedance is selected and the instrument had previously made a relative measurement. Strobe zero

will be applied to RD until the REL/dBm switch is placed in its dBm position. At this time strobe 4 (corresponding to 600 ohms) is applied to RD and causes the controller to select the 600 ohm reference impedance data. This data along with the range and polarity data is then shifted to the ADD/SUB where it is combined with the count referenced to 1200 ohms. The resultant value is now equivalent to a dBm reading referenced to 600 ohms. The range and polarity data is held in the reference latches until RD or J detect a strobe change or unless the instrument is turned off. (Switching to the VOLTS mode will not cause the data in the reference latches to be lost.)

3-39. RELATIVE (REL) REFERENCE

3-40. Relative reference measurements allow any voltage input to become the 0 dB point to which all subsequent voltage inputs are referenced. The controller makes a relative reference computation much the same way it made a dBm computation. However, in the REL mode, 0 dB no longer refers exclusively to 1 mW. The following explains how the controller makes a relative reference measurement.

3-41. Referring the Figure 3-7, you can see that upon selection of the REL mode, the reference impedance data line will be disabled. However, to make a relative reference measurement the controller must use an initial reading, and to obtain an initial reading it must use a

reference impedance. Therefore, before the REL mode can be selected the controller must be allowed to make at least one complete measurement while in the dBm mode. Once the measurement has been completed the REL mode may be selected. The reading will now be fed back to the reference latches and held. The controller will subtract the reading in the reference latches from all subsequent readings. Note that if the instrument is ranged up/down, 20 dB will be added to or subtracted from the reading held in the reference latches. The reading held in the reference latches, however, will be lost any time the instrument is turned off or if the REL switch is released.

3-42. Display and Annunciators

3-43. The computed value of the input to the instrument is transmitted serially as four-bit BCD characters on the W, X, Y, and Z data lines from the Controller to the Seven Segment Decoder see Figure 3-8, Display and Annunciators. The output of the Seven Segment Decoder drives the Display Data Bus, which is common to the inputs of all five of the Display LEDs. Strobe pulses from the Controller determine which Display LED is enabled to accept the data on the Display Data Bus. ST4 through ST7 strobes the seven segment LEDs from LSD to MSD respectively. ST0 gates the ± 1 digit. If the volts display mode is selected, 3 and 1, 2 digits will be enabled, resulting in a resolution of 0.05%. If the dB display mode is selected 4 and 1/2 digits will be

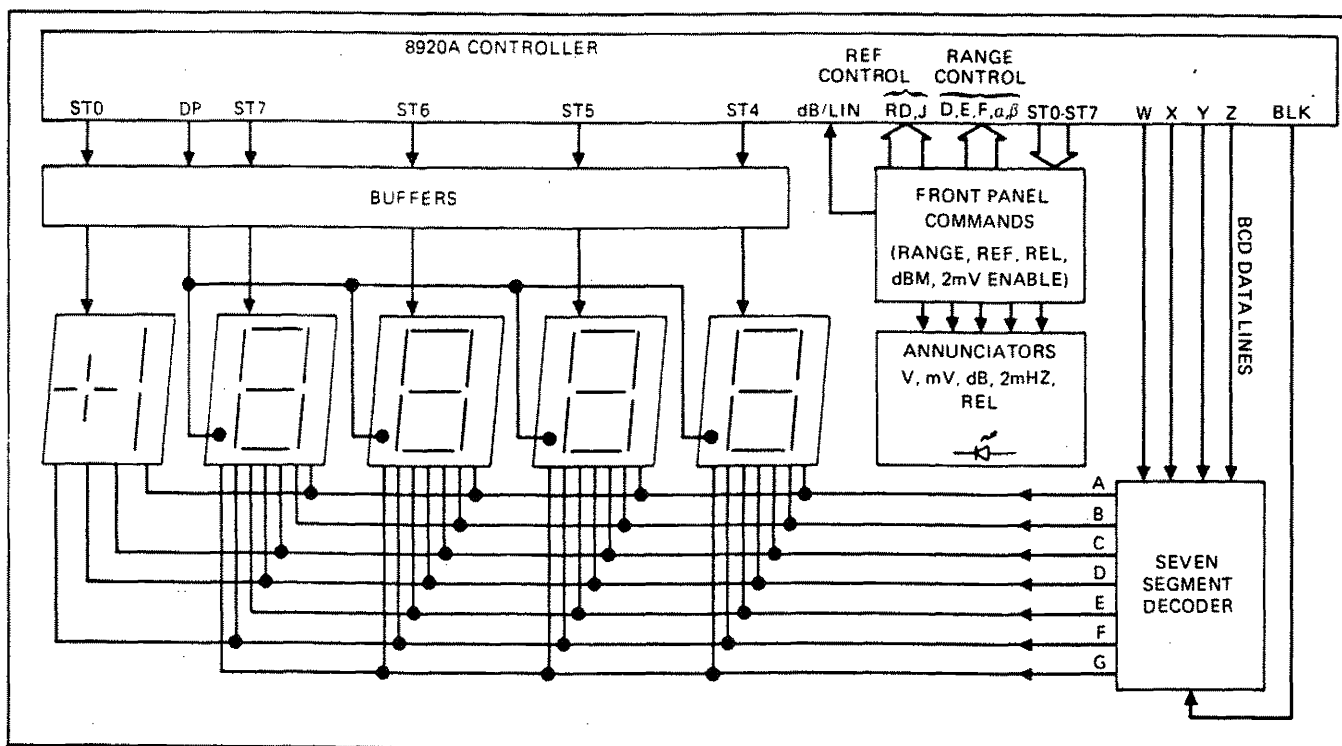

Figure 3-8. Display and Annunciators

enabled and the resolution will be 0.01 dB. The decimal point is enabled separately by the DP line from the Controller.

3-44. The annunciators, excepting the 2 MHz MAX, are strobed on by ST0. ST0 is routed through two circuits. One path is completed when the dB/VOLTS switch is in the dB position. The dB annunciator DS309 is enabled. If the REL/dBm control is in the REL position, RELATIVE REFERENCE annunciator DS308 will also be enabled. If the dB/VOLTS control is in the VOLTS position, ST0 is routed through another path and either the V annunciator DS307 or the mV annunciator DS306 is enabled depending upon the present range of the instrument. If the LO RANGE ENABLE control has the 2 mV range enabled and the instrument is in the 2 mV range, the 2 MHz MAX annunciator will be illuminated to remind the user of the 2 MHz input range of the instrument.

3-45. Power Supply

3-46. The power supply section on the Main PCB provides the instrument with operating voltages and logic levels of +15V, -15V, and +5V.

3-47. Line voltage (100V, 120V, 220V or 240V as selected by controls S209 and S210) is connected to the primary of the main power transformer T200 via POWER switch S208 and fuse F1. The secondary of T200 contains two windings. One winding drives the +5V power supply, the other drives the $\pm 15V$ power supply.

3-48. In the +5V power supply, power from the secondary winding is full wave rectified by CR205, filtered by C211, and regulated by VR203.

3-49. In the $\pm 15V$ power supply, power from the secondary winding is full wave rectified by CR204, filtered by C209 and C210, and regulated into +15V by VR202. The -15V is regulated by U211 and Q207.

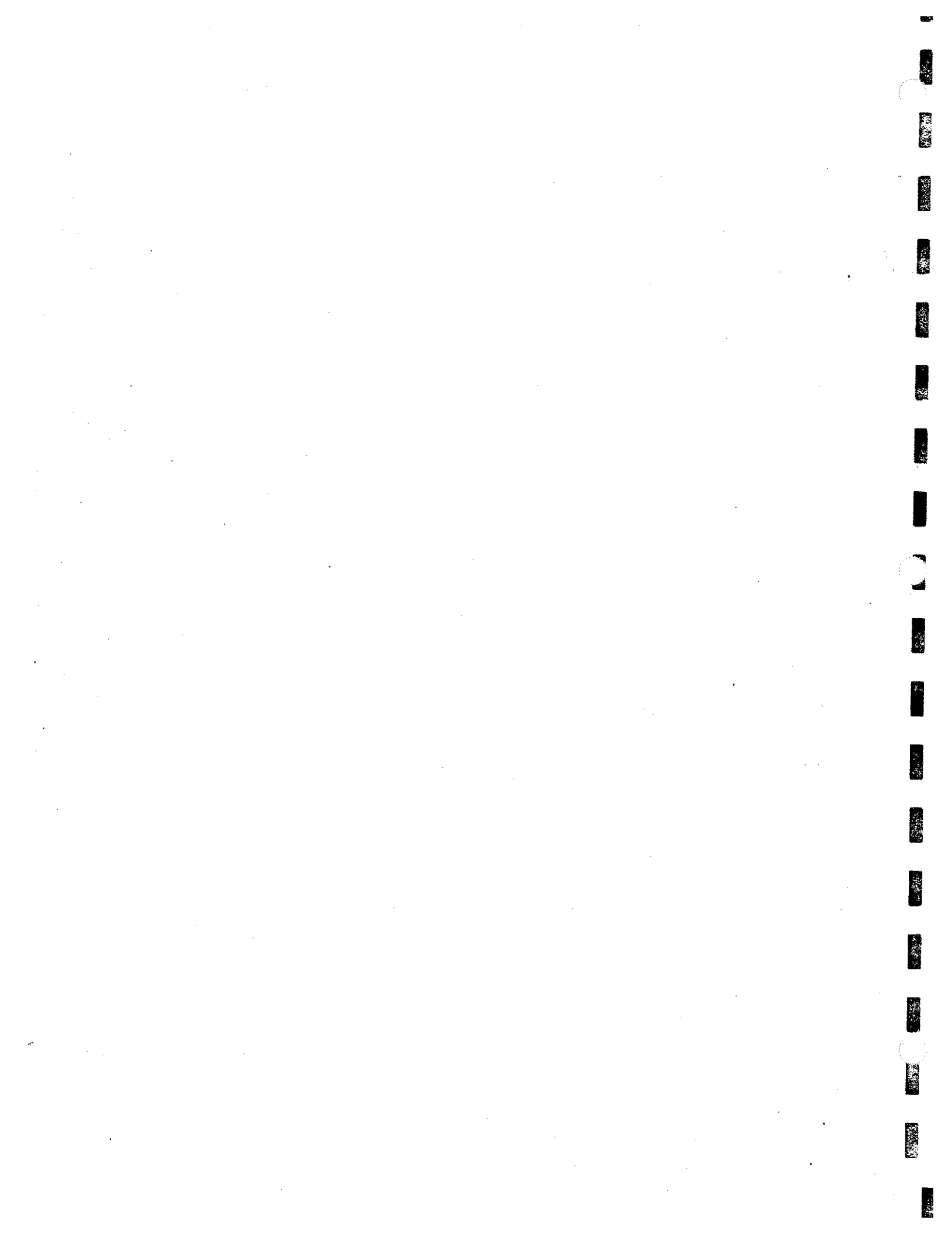

Section 4

Maintenance

WARNING

THESE SERVICING INSTRUCTIONS ARE FOR USE BY QUALIFIED PERSONNEL ONLY. TO AVOID ELECTRIC SHOCK, DO NOT PERFORM ANY SERVICING OTHER THAN THAT CONTAINED IN THE OPERATING INSTRUCTIONS UNLESS YOU ARE QUALIFIED TO DO SO.

4-1. INTRODUCTION

4-2. This section of the manual contains information on service, general maintenance, performance tests, calibration, and troubleshooting. The performance test is recommended as a preventive maintenance tool, and should be executed when it is necessary to verify proper instrument operation. A calibration interval of 90 days is recommended to insure that the 8920A and 8921A perform within the specifications stated in Section 1.

4-3. Table 4-1 lists the recommended test equipment necessary to maintain both instruments. If the specified equipment is not available, other equipment having equivalent specifications may be used.

4-4. GENERAL MAINTENANCE

4-5. Access Information

4-6. To gain access to the interior of the instrument, remove the four #6-32 phillips screws located on the bottom of the case. This loosens the top and bottom, allowing the top cover to be removed.

4-7. INPUT POWER SELECTION

4-8. The 8920A and 8921A may be operated from any one of the line voltages shown in Table 4-2. Use the following procedure to condition the instrument for use with the local line power.

1. Disconnect the instrument from the line power and remove its top cover (four screws on the bottom of the unit hold the top cover in place).
2. Locate the power selection switches S209 and S210 as shown in Figure 4-5.
3. Refer to Table 4-2 and set switches S209 and S210 for desired line voltage.
4. Install the top cover before connecting the unit to line power.

4-9. Cleaning

4-10. Clean the front panel and case with denatured alcohol or a mild solution of detergent and water. Clean dust from the interior of the instrument with dry, low pressure air (20 psi). Contaminants can be washed from the circuit board with demineralized water and a soft brush (avoid getting excessive amounts of water on the switches).









CAUTION

Do not use aromatic hydrocarbons or chlorinated solvents for cleaning. These solutions will react with the plastic materials of the instrument.

Table 4-1. Recommended Test Equipment

EQUIPMENT NOMENCLATURE	REQUIREMENT	RECOMMENDED EQUIPMENT
Precision AC Calibrator and Power Amplifier	19 mV to 600V 20 Hz-50 Hz, $\pm 0.2\%$ 50 Hz-50 kHz, $\pm 0.1\%$	John Fluke 5200A & John Fluke 5205A
DC Voltage Calibrator	$\pm 0.5\% \pm 3 \mu V$ (AC Component $< 100 \mu V$)	John Fluke 341A
Leveled Generator	Short term stability, drift and adjustment resolution $< .1\%$ Freq. range 50 kHz-20 MHz or greater.	Tektronix SG-503/ Series 500 Mainframe
DVM	3 $\frac{1}{2}$ digits, 0.25% Resolution	JF-8020A
Flat Attenuator, 20 dB (three required)	Flatness 50 kHz-1 MHz, $\pm 0.1\%$ 50 kHz-10 MHz, $\pm 0.5\%$ 50 kHz-20 MHz, $\pm 0.7\%$	GR, 874-G20L
1V Transfer Standard	50 kHz-20 MHz, $\pm 0.1\%$	JF-A55 1V
GR Tee Adapter Adapter Adapter Adapter (8921 only)	874 874-BNC (2 required) 874-BNC Banana-BNC BNC-Banana	GR, 874-TL GR, 874-QBPAL GR, 874-QBJAL Pomona 1296 Pomona 1259
Feed thru 50 Ω Termination	1 GHz rated	TEK, 011-0049-01

Table 4-2. Input Power Selection

SWITCH POSITION (REAR PANEL)	SELECTED LINE SOURCE ac $\pm 10\%$, 10 WATTS MAX
<div style="display: flex; justify-content: space-around;"> <div style="text-align: center;"> <p>S209</p>  </div> <div style="text-align: center;"> <p>S210</p>  </div> </div>	120V, 50-400 Hz
<div style="display: flex; justify-content: space-around;"> <div style="text-align: center;">  </div> <div style="text-align: center;">  </div> </div>	100V, 50-400 Hz
<div style="display: flex; justify-content: space-around;"> <div style="text-align: center;">  </div> <div style="text-align: center;">  </div> </div>	220V, 50-400 Hz
<div style="display: flex; justify-content: space-around;"> <div style="text-align: center;">  </div> <div style="text-align: center;">  </div> </div>	240V, 50-400 Hz (250V, MAX)

4-11. Fuse Replacement

4-12. The 8920A and 8921A have one replaceable fuse located on the rear panel which may be replaced with a Buss 1/8 amp, slo blo fuse.

4-13. PERFORMANCE CHECK

NOTE

In the following procedures the instrument (8920A or 8921A) which is being either checked or calibrated is referred to as the UUT (Unit Under Test).

4-14. The performance check provides a means of verifying the overall operation of the UUT. This procedure can be used as an acceptance test for receiving inspection and as a periodic maintenance check. Refer to Table 4-1 for the test equipment recommended for these checks. Should the UUT fail to meet the requirements of these checks, calibration and/or troubleshooting will be necessary. Before starting the performance checks, allow the UUT and the required test equipment to warm-up for at least 30 minutes in an environment of $23 \pm 5^\circ\text{C}$ with relative humidity less than 80%.

NOTE

In all of the procedures in this section, precautions should be taken to minimize ground currents, stray fields, etc.

4-15. Low and Midband Performance Check (Volts Display Mode)

4-16. This procedure will verify that the UUT's low and midband performance is within the limits specified in Section I. Set up the test equipment as shown in Figure 4-1, and select the required function and input signal as indicated in Table 4-3. Note any deviation between the UUT performance and the specified limits.

4-17. dB Display Mode Check

4-18. This procedure will verify that the UUT's dB display mode is functioning properly. Set up the test equipment as shown in Figure 4-1. Depress RANGE HOLD and step up to the 2V range. Select the 1V range on the AC Calibrator and adjust its output for 1.000 on the UUT's display. Select the dB display mode and switch through the dBm REFERENCE selection switch, checking the reading at each position against Table 4-4. The readings should not differ by more than ± 1 digit from the numbers given in Table 4-4.

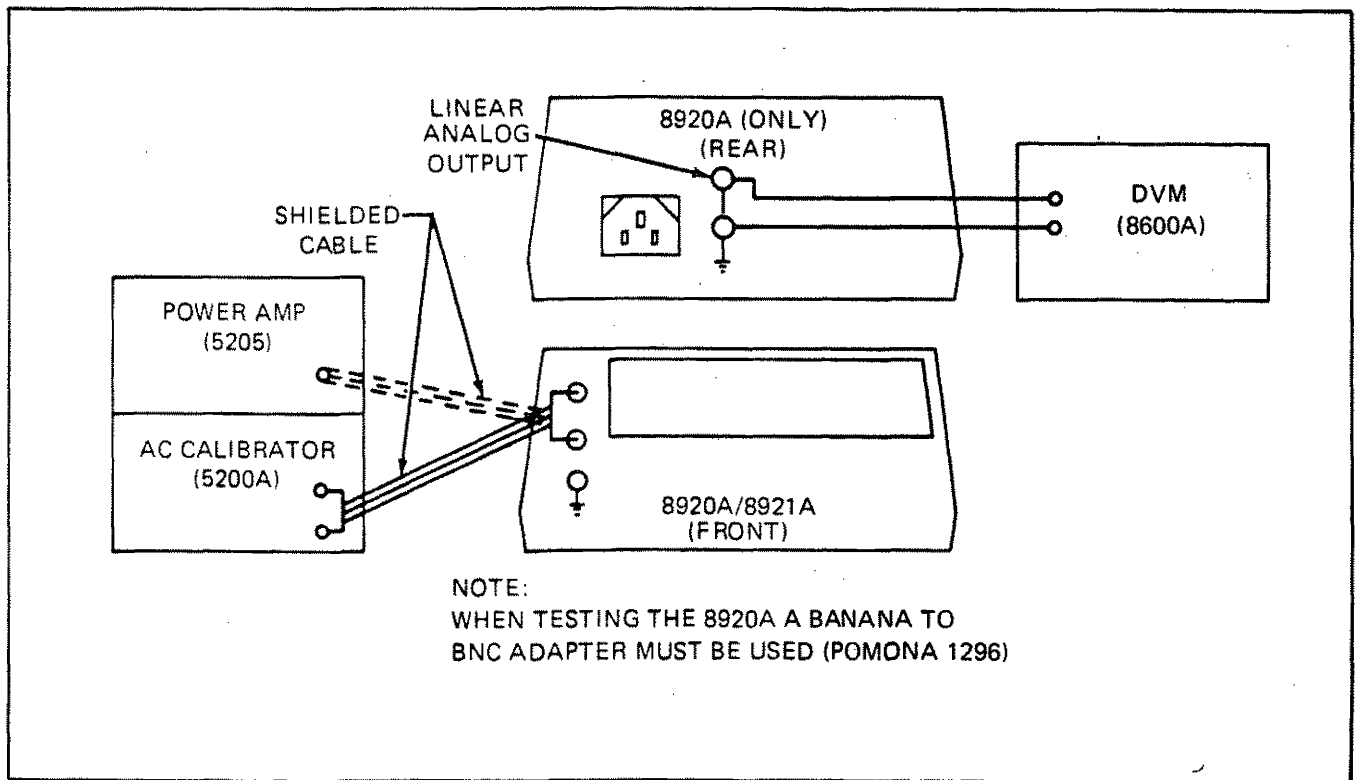

Figure 4-1. Low and Midband Performance Test Set-Up

Table 4-3. Low and Midband Performance Check (Volts Display Mode)

FUNCTION MODE	RANGE	INPUT		DISPLAY	LIMITS or COUNTS	COMMENTS
		LEVEL	F(Hz)			
AC, AUTORANGE	2 mV	1.9 mV	500	1.000	±38	Select the LO RANGE ENABLE and note that the mV and 2 MHz max annunciators are lit.
AC, AUTORANGE	20 mV	10 mV	500	10.00	±10	De-energize the LO RANGE ENABLE and note that the mV annunciator is lit.
AC, AUTORANGE	200 mV	100 mV	500	100.0	±5	Note that the mV annunciator remains lit.
AC, HOLD	2V	3V	500	1.999	n/a	Verify that display flashes 1.999 signifying overrange.
AC, HOLD	2V	1V	500	n/a	±.01V	Measure 1V on the linear analog output (8920A only). Note that the test instrument's reading is within ±.01V of UUT's displayed reading.
AC, HOLD	2V	.2V	500	n/a	±.002V	Measure 0.2V on linear analog output (8920A only). Note that the test instrument's reading is within ±.002V of UUT's displayed reading.
AC, HOLD	2V	.17V	500	.17	n/a	Verify that decimal flashes signifying below 9% of range.
AC, AUTORANGE	2V	1V	500	1.000	±5	Note that the V annunciator is lit.
AC, AUTORANGE	20V	10V	500	10.00	±5	Note that the V annunciator remains lit.
AC, AUTORANGE	200V	100V	500	100.0	±5	Note that the V annunciator remains lit.
AC, AUTORANGE	20 mV	10 mV	50K	10.00	±10	Note that the UUT auto-ranges down to the 20 mV range.
AC, AUTORANGE	200 mV	100 mV	50K	100.0	±5	
AC, AUTORANGE	2V	1V	50K	1.000	±5	

Table 4-3. Low and Midband Performance Check (Volts Display Mode) (cont)

FUNCTION MODE	RANGE	INPUT		DISPLAY	LIMITS or COUNTS	COMMENTS
		LEVEL	F(Hz)			
AC, AUTORANGE	20V	10V	50K	10.00	±5	
AC, AUTORANGE	200V	100V	50K	100.0	±5	
AC, AUTORANGE	700V	600V	500	600	±3	Use the 5205A for this test.

4-19. DC Low Level Check

4-20. This procedure will verify correct operation with low level DC inputs. Set up the test equipment as shown in Figure 4-2, and select the required function, range and input signal as indicated in Table 4-5. Note any deviation between the display of the UUT and the specified limits.

4-21. AC Low Level Check

4-22. This procedure will verify that the UUT's low level AC performance meets the specifications of Section 1. Set up the test equipment as shown in Figure 4-3 and complete the AC Low Level Calibration procedure. Replace steps 2-d and 2-e with the following:

2-d. Note that the UUT's display reads the same error as noted in step 1-f ± 38 digits.

2-e. Note that the UUT's display reads 0.1900 ± 4 digits.

4-23. High Frequency Response Check

4-24. This procedure will verify that the UUT's high frequency response meets the specifications of Section 1. Set up the test equipment as shown in Figure 4-4, and select the required input amplitude and frequency as indicated in Table 4-6. Note any discrepancies between the display reading and the limits given.

4-25. CALIBRATION

4-26. Under normal conditions the 8920A and 8921A should be calibrated every 90 days to maintain the specification given in Section 1 of this manual. If instrument repairs have been made or if the unit fails any of the performance checks, calibration is required. Use the test equipment as listed in Table 4-1.

4-27. Use the following procedures to calibrate the 8920A or 8921A. Access to all calibration and test points

(see Figure 4-5) may be obtained by removing the top cover (see Access and Removal). The UUT should be allowed to warm-up for 30 minutes before calibration.

4-28. Power Supply Calibration

WARNING

IN ALL PROCEDURES WITH THE TOP COVER REMOVED THE OPERATOR SHOULD BE AWARE THAT THE FOLLOWING POINTS ARE AT LINE POTENTIAL:

1. POWER LINE CONNECTOR.
2. ALL LAND PATTERNS NEAR POWER TRANSFORMER.
3. POWER SWITCH.
4. FUSE HOLDER.

4-29. Use the following procedure to calibrate the power supplies of the UUT.

1. Place all front panel switches to the out position.

CAUTION

Certain overload protection depends on the supply voltages. To avoid possibility of damage, do not adjust the $\pm 15V$ supplies with the UUT in overrange.

2. Monitor TP206, with a DVM using TP205 as a voltmeter common.
3. Adjust R229 for $+15V \pm 0.1V$ on TP206.
4. Check TP208 for $-15V \pm 0.2V$.
5. If TP208 does not comply, recheck TP206 and adjust R229 if necessary.
6. Check TP207 for $+5V \pm 0.25V$.

Table 4-4. dB Display Mode Check

MODE	REFERENCE OHM	SOURCE	DISPLAY READING	COMMENTS
dBm	50	1.000	+13.00	Note that the dB annunciator is lit.
dBm	75	1.000	+11.24	
dBm	93	1.000	+10.31	
dBm	110	1.000	+9.58	
dBm	124	1.000	+9.06	
dBm	135	1.000	+8.69	
dBm	150	1.000	+8.23	
dBm	300	1.000	+5.22	
dBm	600	1.000	+2.21	
dBm	900	1.000	+ .45	
dBm	1000	1.000	- .01	
dBm	1200	1.000	- .80	
REL		1.000	+0.00	Note that the dB and REL annunciators are lit.
REL		10.00	+20.00	Step up to the 20V range (note that the dB and REL annunciators remain lit).

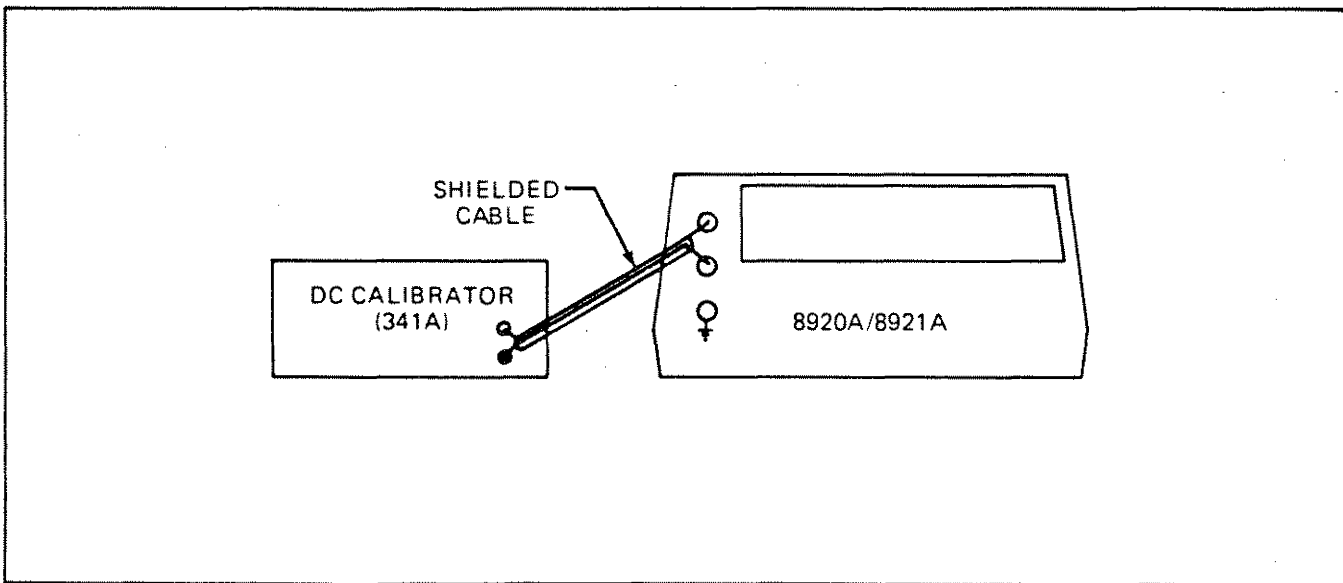

Figure 4-2. DC Low Level Check Test Set-Up

Table 4-5. DC Low Level Check

DC INPUT	RANGE	FUNCTION	UUT DISPLAY ±6 COUNTS	COMMENT
1V	2V	AC + DC	1.000 ±30 counts	UUT dc circuitry functioning.
2 mV	AUTO (depress LO RANGE ENABLE)	AC + DC	02.00 or mVrms (see comment) ±6 counts	The ac input component should be less than 0.2 mV. The mVac component can be measured by temporarily selecting the AC and LO RANGE ENABLE switches. If it is greater than 0.2 mV; $mV_{rms} = \sqrt{(2 mV_{dc})^2 + (mVac)^2}$

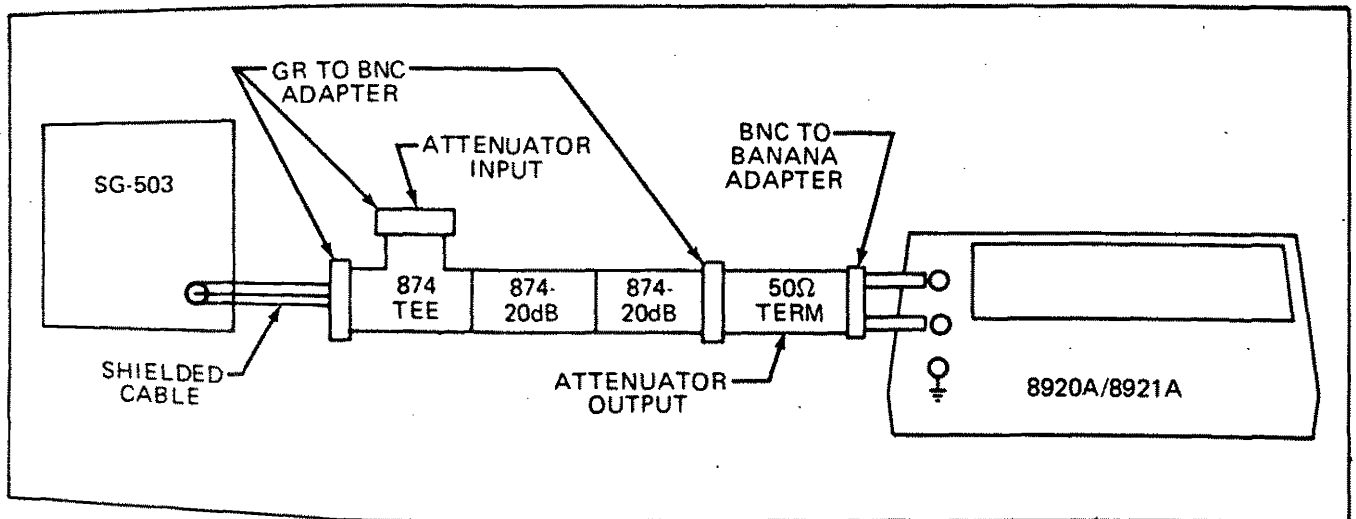

Figure 4-3. AC Low Level Check Test Set-Up

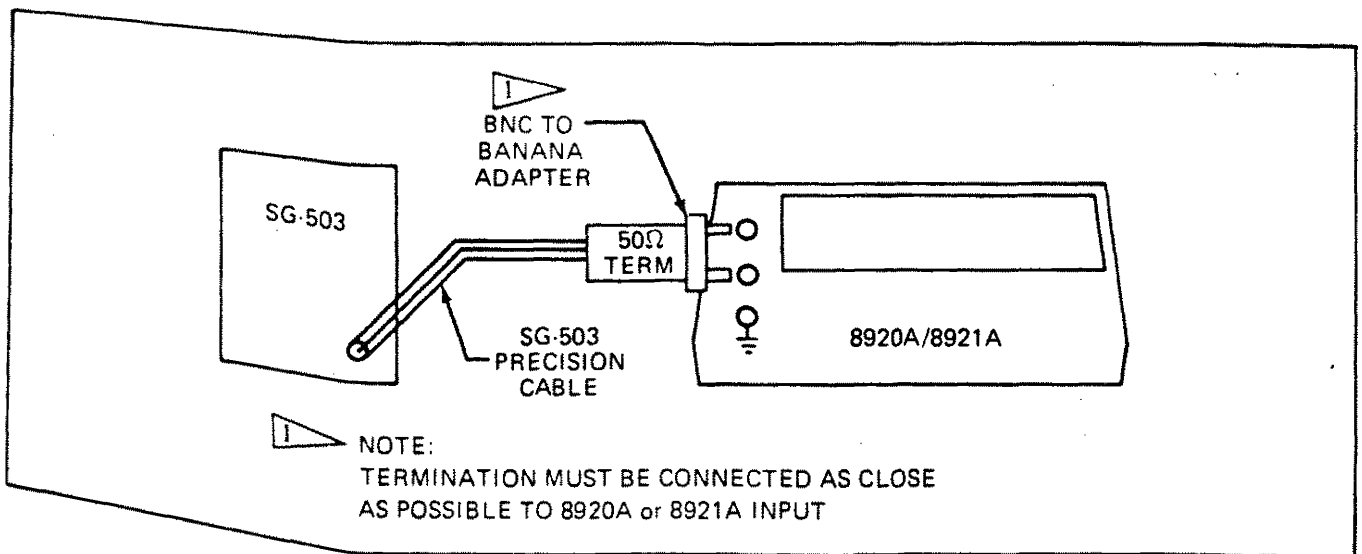
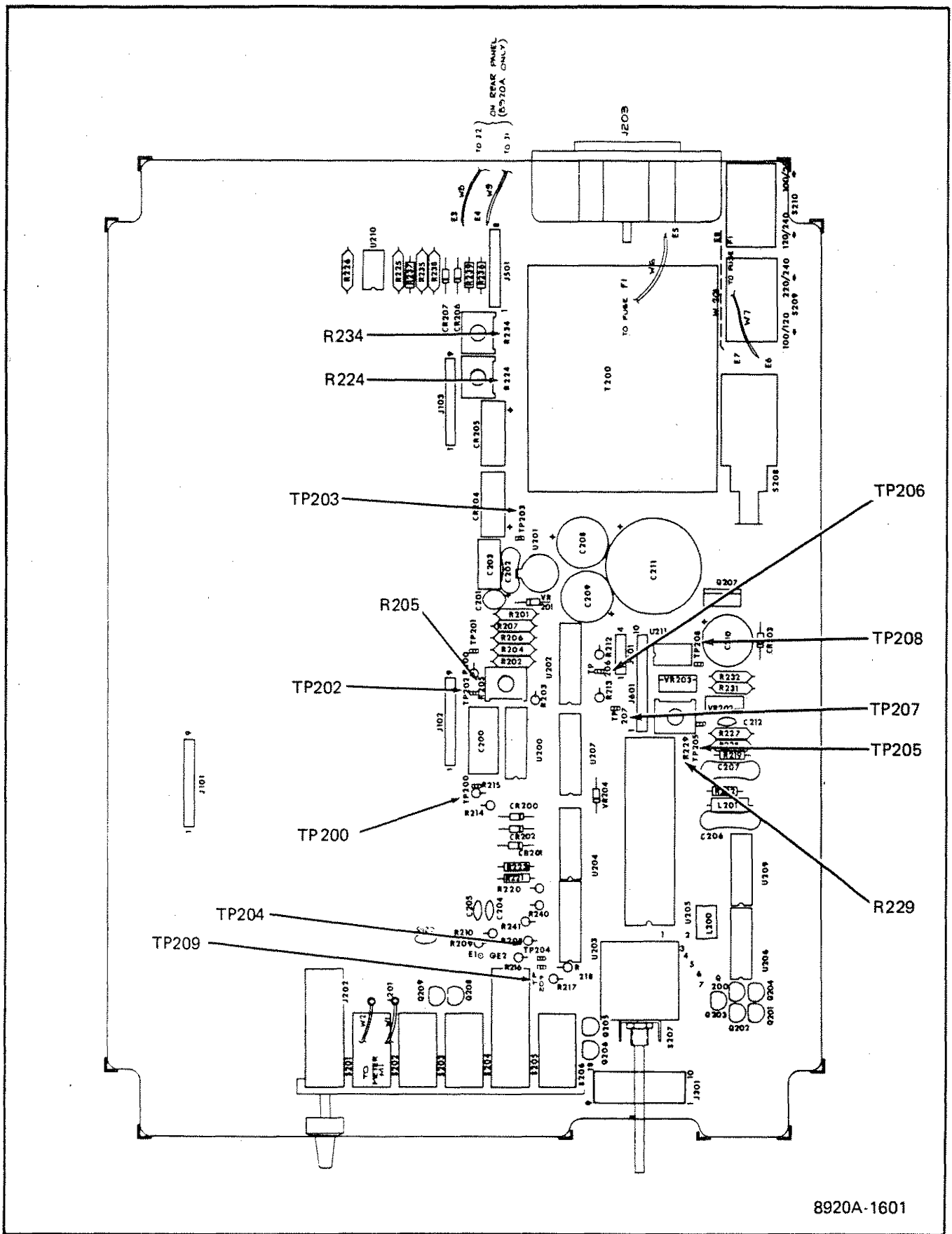

Figure 4-4. High Frequency Response Check Test Set-Up



8920A-1601

Figure 4-5. Calibration and Test Point Locations

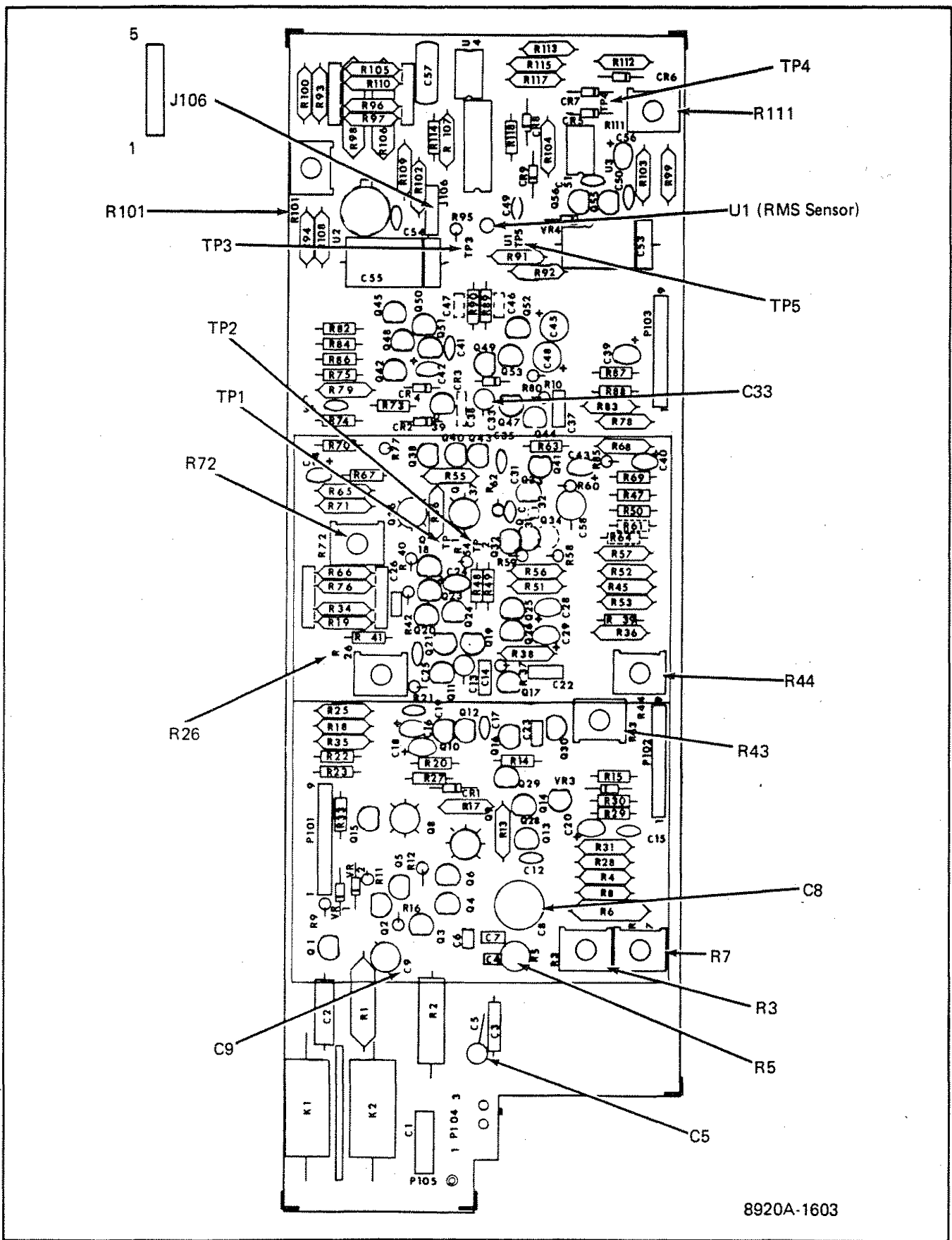

Figure 4-5. Calibration and Test Point Locations (cont)

Table 4-6. High Frequency Response Check

FUNCTION MODE	RANGE	INPUT		DISPLAY	LIMITS ±COUNTS	COMMENTS
		LEVEL	F(Hz)			
AC, AUTORANGE	20 mV	17 mV	50K	17.00		Adjust the SG503 amplitude so that the display reads 17.00.
AC, AUTORANGE	20 mV	17 mV	20M	17.00	±85	Readjust the input frequency without changing the amplitude.
AC, AUTORANGE	200 mV	170 mV	50K	170.0		Adjust the SG503 amplitude so the display reads 170.0.
AC, AUTORANGE	200 mV	170 mV	20M	170.0	±85	Readjust the input frequency without changing the amplitude.
AC, AUTORANGE	2V	1.7	50K	1.700		Adjust the SG503 amplitude so the display reads 1.700.
AC, AUTORANGE	2V	1.7	20M	1.700	±85	Readjust the input frequency without changing the amplitude.

4-30. Low and Midband Accuracy Adjustment

4-31. Use the following procedure to calibrate the low and midband accuracy of the UUT.

1. Place all the front panel switches in the out position, except LO RANGE ENABLE.
2. Short TP204 to TP209 to light the 4th display digit.
3. Apply the input voltages and frequencies as listed in Table 4-7, and adjust to the limits given. If any limit cannot be reached, see Troubleshooting, Table 4-9.

4-32. Linear Analog Output (8920A only)

4-33. Use the following procedure to calibrate the 8920A's Linear Analog Output.

1. Set up the calibration test equipment as shown in Figure 4-6.
2. Select AC and AUTORANGE.
3. Apply 1.000V, 500 Hz to the input and monitor the dc voltage at the rear panel linear analog output

(LAO). Adjust R224 for the same reading as the display ±2 mV.

4. Observe that the null/peak meter reads center of scale ±1.2 division.
5. Push RANGE HOLD and decrease the input to 0.1V, 500 Hz. The output voltage should read the same as the front panel display ±0.2mV. If it is not within this limit, adjust R234 and go back to step 3.
6. Increase the input to 0.5V. The voltage at the output should be the same as the front panel display ±0.001V.

4-34. AC Low Level Calibration

4-35. Use the following procedure to calibrate the UUT's AC low level performance.

1. Measure the 503 Attenuator Errors (leveled generator).
 - 1-a. Place all front panel switches out except LO RANGE ENABLE.
 - 1-b. Set up the test equipment as shown in Figure 4-3.

1-c. Set the leveled generator to 50 kHz, X1 and connect the 874-20 dB-GR attenuator input to the input of the UUT.

1-d. Adjust the leveled generator amplitude until a steady reading of 1.000V is obtained on the display of the UUT.

1-e. Switch the leveled generator to the X.1 setting, observe that the UUT autoranges down to the 100 mV range and note the reading error.

1-f. Switch the leveled generator to the X.01 setting and note that the reading error is less than 10 digits on the 20 mV range.

2. Calibrate the 2 mV range:

2-a. Connect the 50 ohm terminated attenuator output to the input of the UUT.

2-b. Switch the leveled generator to the X1 and adjust the amplitude such that a steady reading of 10.00 mV is obtained on the UUT.

2-c. Switch the leveled generator to the X.1 setting allowing the UUT to range down to the 2 mV range.

2-d. Adjust R44 so that the display of the UUT reads the same error as noted in step 1-e, ± 1 digit.

2-e. Depress the RANGE HOLD switch, readjust the leveled generator for a reading of 1.900 ± 1 digit and switch down to the X.01 setting. The UUT's display reading should be from 0.190 to 0.192 after settling.

Table 4-7. Low and Midband Accuracy Adjustments

STEP	INPUT V	RANGE (AC)	FREQ Hz	ADJUST	READ DISPLAY	LIMIT \pm of READING
1	1	2V (AC)	500	—	Note reading.	n/a
1a	Select RANGE HOLD.					
1b	0.1	2V	500	R101	1/10 of reading in step 3.	3 digits
1c	Return to step 1 if R101 was readjusted.					
1d	Select AUTORANGE.					
2	2.5V dc	20V (AC+DC)	n/a	R72	2.500	± 10 digits
2a	0.25 Vdc	2V (AC+DC)	n/a	R26	.2500	± 10 digits
3	Return to step 2 if R26 was readjusted.					
4	100 mV	200 mV	500	R205	100.00	5 digits
5	1.9 mV	2 mV	500	R44	1.9000	40 digits
5c	Return to step 4 if R44 was readjusted.					
6	100 mV	200 mV	50K	C9	100.00	5 digits
7	1	2V	500	R3	1.0000	5 digits
8	1	2V	500	R224	Meter (8921A only).	Mid-scale

Table 4-7. Low and Midband Accuracy Adjustments (cont)

STEP	INPUT V	RANGE (AC)	FREQ Hz	ADJUST	READ	LIMIT ± of READING
9	100	200V	500	R7	100.00	5 digits
10	1	2V	50K	C5	1.0000	5 digits
11	100	200V	50K	C8	100.00	10 digits
11c	Return to step 10 if C8 was readjusted.					
12	10 mV	20 mV	500	Chk	10.000	20 digits
13	10 mV	20 mV	10K	Chk	10.000	20 digits
14	10 mV	20 mV	50K	Chk	10.000	20 digits
15	10	20V	500	Chk	10.000	5 digits
16	10	20V	10K	Chk	10.000	20 digits
17	10	20V	50K	Chk	10.000	5 digits
18	10	20V	20K	Chk	10.000	0 to -70 digits
19	Remove the short between TP204 and TP209.					
20	Autorange into the 20 mV range and push RANGE HOLD.					
21	Monitor the DC voltage on TP4 with a DVM and apply 20.6 mV, 500 Hz to the input.					
22	Note the DVM reading.					
23	Increase the input to 206 mV and check the DVM for a reading .07 + .02V or -.01V smaller than the reading noted in the previous step. If the reading is outside these limits, refer to the calibration procedure of the rms sensor protection "RMS Protection Circuit Calibration".					

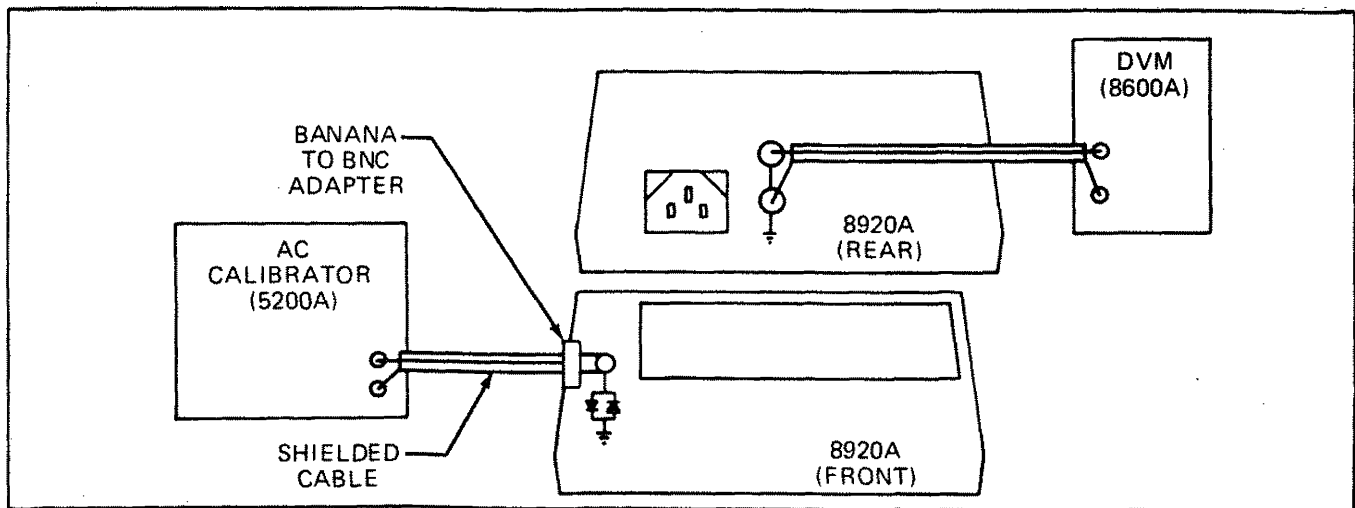

Figure 4-6. Linear Analog Output Test Set-Up (8920A only)

4-36. High Frequency Calibration

4-38. RMS Protection Circuit Calibration

4-37. Use the following procedure to calibrate the UUT's high frequency response.

1. For the ranges shown in Table 4-8, adjust the amplitude of the leveled generator at 50 kHz to establish a reference (refer to Figure 4-7, for the test setup). Use one 20 dB attenuator for 0.1V, two attenuators for 0.01V, and three attenuators for .001V terminated with 50 ohms. Take care not to overdrive the transfer standard.

2. Note the reading at the output of the A55 transfer standard and maintain this by readjusting the generator's level for other frequencies.

CAUTION

R111 controls the protection circuit for the RMS Sensor. DO NOT make any adjustments to R111 other than those listed below. Indiscriminate adjustments may cause component damage.

4-39. Use the following procedure to calibrate the protection circuit of the rms sensor. This procedure should be completed only if the rms sensor or any component in the protection circuit has been replaced or if the limit in step 22 of Table 4-9 cannot be met.

Table 4-8. High Frequency Calibration

STEP	SOURCE LEVEL	UUT RANGE	SOURCE FREQ.	ADJUST	UUT DISPLAY	LIMIT ± COUNTS
1	.001	2 mV	50K	source	1.000	±1
2	.001	2 mV	2M	R43	1.000	±2
3	.001	2 mV	.	Chk	1.013	±3
4	0.01	20 mV	50K	source	10.00	±1
5	0.01	20 mV	20M	C33	10.00	±3
6	0.01	20 mV	10M	Chk	10.00	0 to +20
7	0.01	20 mV	1M	Chk	10.00	±3
8	0.1	200 mV	50K	source	100.0	±1
9	0.1	200 mV	20M	C58	100.0	±10
10	1.	1.	50K	source	1.000	±1
11	1.	1.	20M	R5	1.000	±1
12	1.	1.	10M	Chk	1.000	0 to +10
13	1.	1.	1M	Chk	1.000	±3

*Reduce the frequency to the point between 1 and 2 MHz where the maximum reading on the display occurs. If too high, turn C13 clockwise a few turns. If it is too low, turn C13 counterclockwise. Then return to step 1 of this table.

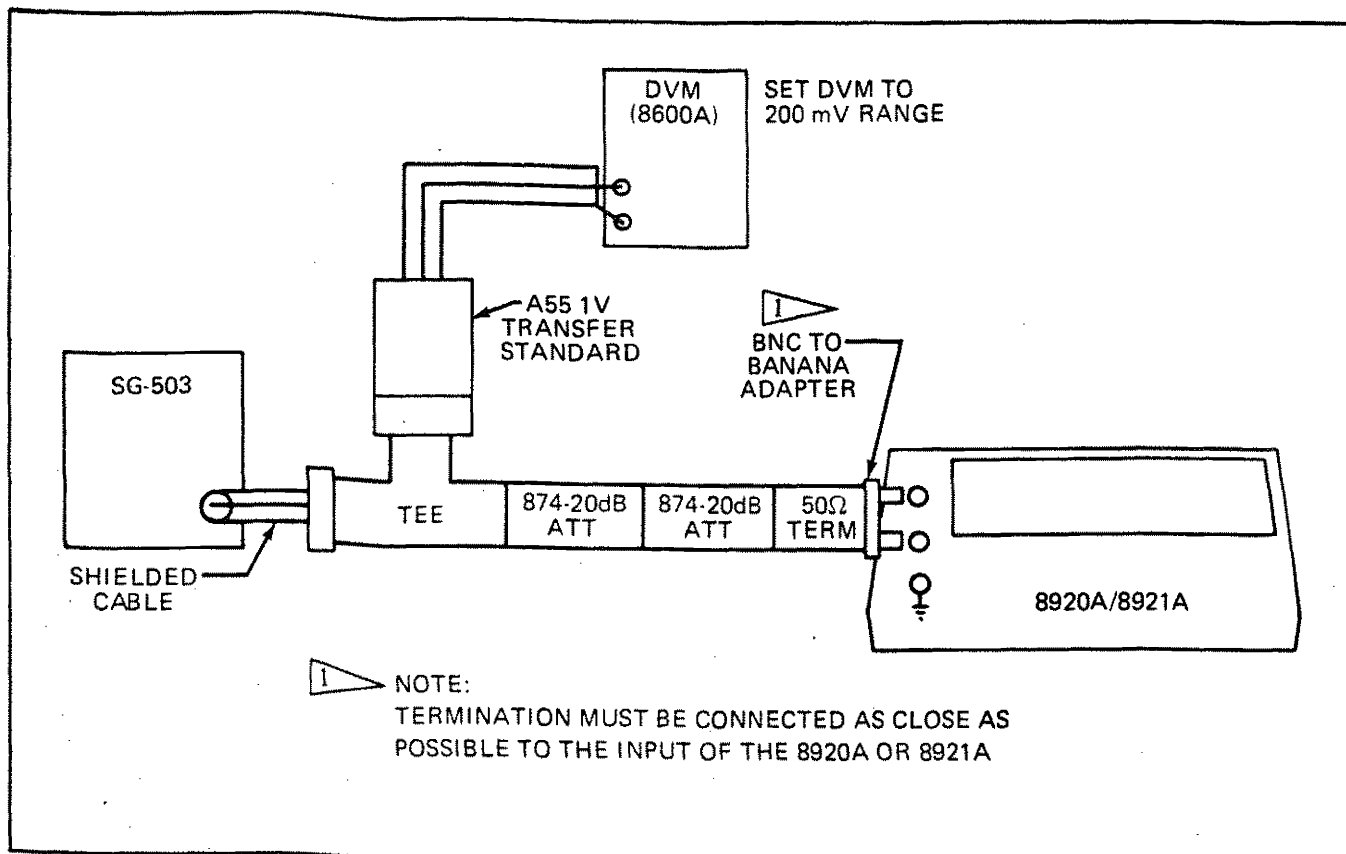

Figure 4-7. High Frequency Calibration Test Set-Up

NOTE

The ambient temperature must be $23^{\circ}\text{C} \pm 5^{\circ}\text{C}$ and the $\pm 15\text{V}$ supplies must be calibrated.

1. Remove the tape dot on R111 and turn R111 to its Max CCW position.
2. Select AC, AUTORANGE then HOLD to lock the UUT in the 20 mV range. Refer to Figure 4-5 for the calibration and test point locations. Monitor the voltage at TP4 with a DVM and apply 20.6 mV, 200 Hz to the input.
3. Turn R111 slowly clockwise until the DVM reading stops decreasing. Note the DVM reading and turn R111 back slightly CCW. Increase the input to 25.6 mV and CAREFULLY adjust R111 clockwise for a reading on the DVM $.07\text{V} \pm .002$ smaller than the noted reading. DO NOT ADJUST FURTHER OR THE SENSOR MAY FAIL. Now increase the input to 256 mV, 2 kHz. The voltage at TP4 should not change by more than 20 mV.
4. Replace the tape dot on R11 or use Glyptol.

4-40. TROUBLESHOOTING

4-41. This section contains information selected to assist in troubleshooting the Model 8920A/8921A. Before attempting to troubleshoot the instrument, however, it should be verified that the trouble is actually in the instrument and is not caused by faulty external equipment or improper control settings. For this reason, the Performance Check is suggested as a first step in troubleshooting. The Performance Check may also help to localize the trouble to a particular section of the instrument. If the Performance Check fails to localize the trouble, the following information may be helpful. Location of principal circuitry areas, test points and adjustment locations in the Model 8920A/8921A is shown in Figure 4-5.

4-42. When troubleshooting the UUT, the following points should be kept in mind.

1. Before any troubleshooting is begun, make a visual inspection of the interior of the instrument.
2. When troubleshooting the AC Amplifiers, isolate the DVM test lead with a 10 kΩ probe, otherwise capacitive loading may cause the AC Amplifiers to oscillate.

3. MOS type integrated circuits can be damaged by discharging static electricity through the device. All circuits of this type are designated on the schematic with this symbol \otimes . Use care and always use a grounded soldering iron when removing or installing MOS devices.

4-43. A troubleshooting guide for the 8920A and 8921A is presented in Table 4-9. This guide is in a tabular flow chart form and is recommended for use in isolating a problem to a functional circuit area. The initial steps in the troubleshooting guide refer to the Performance Checks made earlier in this section.

4-44. RMS Sensor Replacement

4-45. Use the following procedure when replacing the rms sensor. This procedure should be completed if the troubleshooting procedure indicates that the rms sensor must be replaced, refer to Figure 4-5.

1. Carefully unsolder the defective sensor from the AC PCB using a grounded soldering iron.
2. Install the new sensor (be sure that the sensor spacer pad is in place) and replace the AC Assembly and shield.
3. Remove R97 or R105, if installed, and replace with the buss wire from the sensor kit.
4. Remove R96 and R110, if installed.
5. Plug the protection diode fixture into J106. Note that the fixture is symmetrical.
6. Turn R111 to its maximum counterclockwise position.
7. Place all of the front panel switches to their out position and apply power to the instrument.
8. Select AC+DC, RANGE HOLD and up range to the 2V range. Monitor TP3 with a DVM, connect a DC Calibrator to the input and apply +1.8V dc. The sensor input should now be clamped by the protection circuit and TP3 should read about half the display reading.
9. Turn R111 slowly clockwise and observe that the DVM and instrument display readings increase.

The dc voltage at TP3 should stop increasing at around +0.8 to +1.0V. The instrument display should stop increasing around 1.5 to 1.99V, the point at which the protection diodes clamp the input. **DO NOT ALLOW THE INSTRUMENT TO GO INTO OVERLOAD.** Return R111 to its CCW stop and repeat the procedure with a negative dc input. Turn R111 CCW until TP3 reads about -.5V and remove the calibrator and the protection diode fixture.

10. Short the input, select AC, RANGE HOLD and step up range to the 2V range. Monitor TP3 and adjust R72 for 0 ± 1 mV dc.

11. Select AC+DC and adjust R26 for 0 ± 1 mV dc on TP3.

12. Go to the rms protection circuit calibration procedure, "RMS Protection Circuit Calibration", and complete the steps as listed. Return to step 13 below.

13. Perform calibration steps 1 through 1c, as listed in Table 4-7, Low and Midband Accuracy Adjustments. Should R101 not have enough adjustment range, substitute one of the kit resistors (15 k Ω , 30.1 k Ω , or 45.3 k Ω) for R105 if reading is too high, R97 if reading is too low or zero.

14. Monitor the ac voltage at TP5* with a DVM and apply 100 mV, 20 Hz to the input with the instrument in the 200 mV Range.

15. If the monitored ac voltage is 36.0 mV or greater, install the 402 k Ω resistors for R96 and R110.**

16. If the monitored ac voltage is still 36.0 mV or greater, install the 158 k Ω resistors for R96 and R110.**

17. If the UUT is operating correctly, repeat the entire CALIBRATION procedure, otherwise return to beginning of Table 4-9.

*For AC PCB Assembly, Rev A, monitor CR9 cathode or J501 pin 3.

**For AC PCB Assembly, Rev A, solder R96 and R110 piggyback on R107 and R108.

Table 4-9. 8920A/8921A Troubleshooting Procedure

STEP NO.	INSTRUCTION	YES	NO	GOTO
1	All front panel switches should be in the out position.			2
2	Connect the UUT (8920A/8921A) to appropriate line power and observe the display.		3	
3	Does display light correctly?	4	11	
4	Apply 1V ac input to UUT, select AC function, VOLTS display mode and AUTORANGE.			5
5	Does UUT respond to input?	6	17	
6	Does UUT pass the Low-Midband Check?	7	25	
7	Does UUT pass the Low Level DC Check?	8	26	
8	Does UUT pass the High Frequency Response Check?	9	28	
9	UUT operating properly.			10
10	Apply 1V ac to UUT in the 2V ac range.			17
11	Check appropriate display drivers, Q200-Q204.	12	23	
12	Correct power supply test point voltages are as follows: TP206 = +15V; TP207 = -5V; TP205 = power supply ground.			13
13	Is TP206 at +15V?	14	29	
14	Is TP208 at -15V?	15	31	
15	Is TP207 at +5V?	16	32	
16	Power supply is operating properly.			10
17	Check voltage between TP201 and TP202.			18
18	Is the voltage 0.5V, $\pm 10\%$?	19	33	
19	Does null/peak meter read approximately $\frac{1}{2}$ scale?	20	40	
20	Check A/D Converter, is it operating correctly?	24	21	
21	Check TP200, is it at +6.4V?	22	42	
22	Check the following for appropriate A/D Converter waveforms: U200-U202, U205 and TP203. Refer to Figure 4-8.			23
23	Replace defective component.			24
24	Repeat Performance Tests and Calibration.			1
25	Check attenuator logic levels using Table 4-10.	10	23	
26	Are S1 and Q33 switching properly?	27	23	
27	Check Amp A & B.			10
28	Check Amp A & B and attenuator network.			10
29	Remove AC PCB, is TP206 at +15V now?	30	43	

Table 4-9. 8920A/8921A Troubleshooting Procedure (cont)

STEP NO.	INSTRUCTION	YES	NO	GOTO
30	Troubleshoot AC pcb assembly.			23
31	Remove AC pcb, is TP208 at -15V?	30	44	
32	Check: VR203, U200-U202, U205, U206, U209, U210, U211, U4 and U302.			23
33	Check TP3.			34
34	Is voltage on TP3 at 0.5V ±10%?	35	45	
35	Turn UUT off, disconnect UUT from line power.			36
CAUTION				
To avoid damage to the RMS sensor, steps 37 and 38 must be performed with a multimeter whose output on the ohms function is no greater than 10 mA.				
37	Is the resistance of U1-6 to U1-7 (or J106-2 to J106-3) 90 ohms ±8%. (Out of circuit resistance = 100 ohms ±8%.)	38	50	1
38	Is the resistance of U1-8 to U1-9 (J106-4 to J106-3) = 100 ohms ±8%.	39	50	
39	Check U2, U4 and U5.			23
40	Check test point E3, is it at +1V ±5%?	41	51	
41	Check meter and U210B.			23
42	Check VR201.			23
43	Check VR202.			23
44	Check U203 through U207.			23
45	Check TP1.			46
46	Is TP1 at 0.045V ±10%?	47	52	
47	Check TP2.			48
48	Is voltage on TP2 at 0.045V ±10%?	49	54	
49	Check Amp B. Refer to the AC Amplifier schematic for voltage check points.			23
50	Replace rms sensor, refer to RMS Sensor Replacement Procedure.			1
51	Check U201A.			23
52	Check Q3, Q4, Q5 and Q6 (refer to Table 4-10) are they switching properly?	53	23	
53	Check Amp A. Refer to the AC Amplifier schematic for voltage check points.			23
54	Check Q31, Q32 and Q33.			23

A/D WAVEFORMS (GENERAL CONDITIONS)
 8920A/8921A READING 1000 COUNTS
 SCOPE TRIGGERED ON - SLOPE OF A2
 (PIN 38) X10 SCOPE PROBE (10 MΩ)

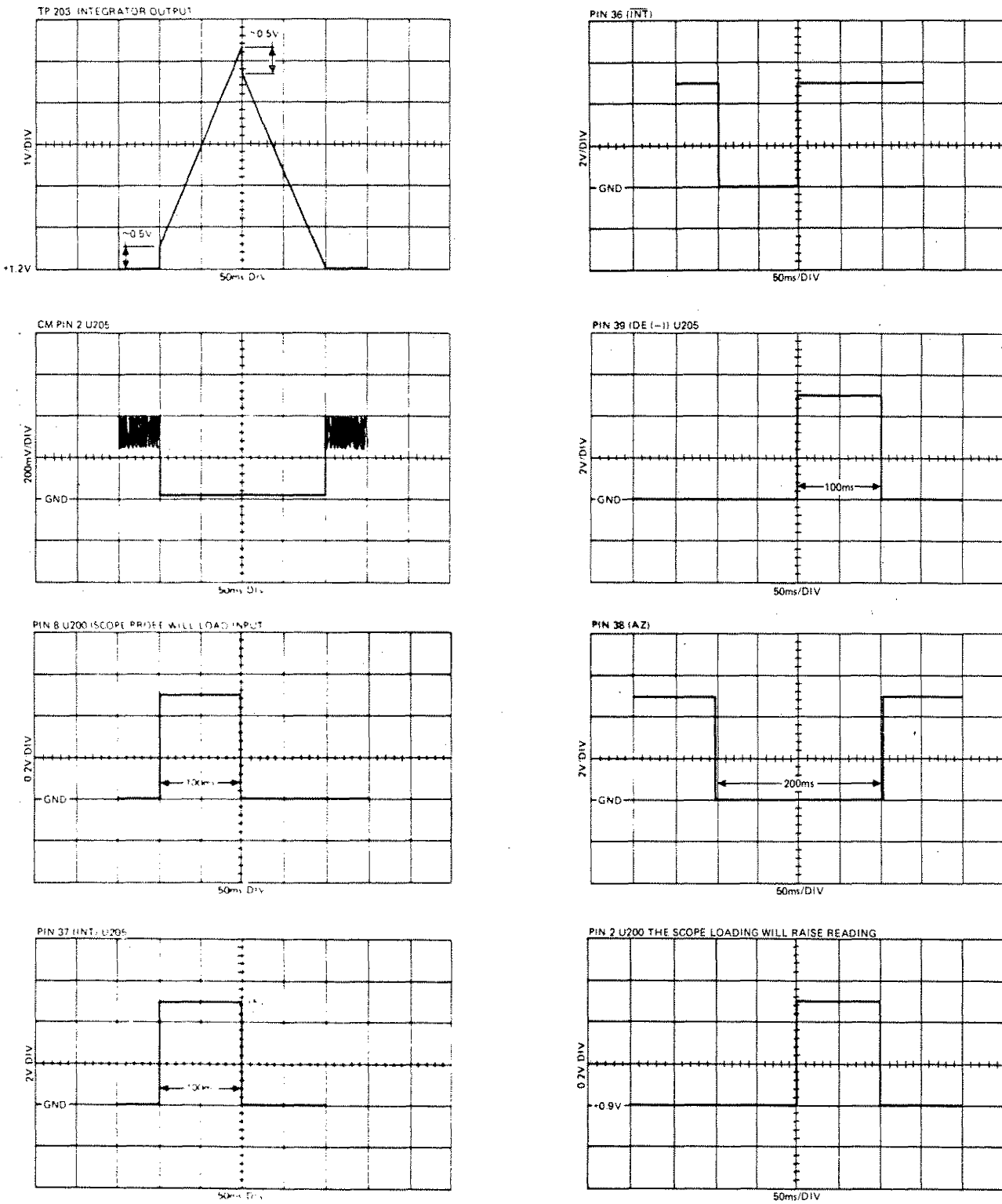

Figure 4-8. A/D Waveforms (General Condition)

Table 4-10. Attenuator Logic States

RANGE	K1	K2	Q3*	Q4*	Q5*	Q6	Q29*	Q28/Q30	Q31*	Q32
700V	0	1	0	1	1	0	1	0	1	0
200V	0	1	0	1	1	0	1	0	0	1
20V	0	1	1	0	1	0	1	0	1	0
2V	0	1	1	0	1	0	1	0	0	1
200 mV	1	0	0	0	0	1	1	0	1	0
20 mV	1	0	0	0	0	1	1	0	0	1
2 mV	1	0	0	0	0	1	0	1	0	1

LOGIC LEVELS

- 1 = 0V
- 0 = -15V
- *1 = -1.9V ±10%
- *0 = -14.8V ±10%

4-46. A/D Calibration Resistor Selection

4-47. This procedure is used to determine the correct A/D selected resistor, R204, and should be completed whenever VR201 is replaced or when R1205 does not have enough range to calibrate the A/D. All possible values for R204, listed in Table 4-11, may be obtained in a set by ordering Part #490722.

NOTE

The UUT may go into overrange with R204 removed.

1. Place all front panel switches in the out position and set T205 to the center of its adjustment range.
2. Apply 100.09 mV, 200 Hz to the input and select resistors R204 from Table 4-11, until the display reads closest to 100.0 mV.
3. Verify that R205 has adjustment range on both sides of the displayed 100.0 mV reading.
4. Perform the instrument calibration.

4-48. DC Offset Resistor Selection

4-49. Use this procedure to determine the correct DC offset selected resistors, R19 to R34 for amplifier A and or R66 or R76 for amplifier B. Use the procedure when the amplifier offset cannot be adjusted to 0V with R26 and or R72; usually because one or more of the following have been replaced:

- Amplifier A Q9/R17 (set), Q8, Q10, and Q12
- Amplifier B Q36, Q37/R46 (set), Q38, and Q40

All possible values for R19 or R34 (amplifier A) or R66 or R76 (amplifier B), listed in Table 4-12, may be obtained in a set by ordering Part #490730. Two sets will be necessary if both amplifiers require the same selected resistor value.

4-50. SET UP

1. Remove the cover shield of the AC Converter PCB.
2. Connect a short jumper between input low and the metal fence on the AC Converter PCB.

4-51. AMPLIFIER B
(must be done before Amplifier A)

3. Apply power, short the input, select AC, RANGE HOLD and step up to the 2V range.
4. Set R72 to the center of its adjustment range and monitor TP3 with a DVM.

5. Select resistors from Table 4-12, starting with the highest value until the DVM reads closest to 0 volts dc. Place the resistor in the socket for R66 if the DVM reads positive, R76 if the reading is negative. Adjust R72 for a DVM reading of less than 1 mV dc at TP3.

4-52. AMPLIFIER A

6. Select AC+DC, set R26 to the center of its adjustment range and monitor TP3 with a DVM.
7. Select resistors from Table 4-12, starting with the highest value until the DVM reads closest to 0V

Table 4-11. R204 Resistive Values (mF, $\pm 1\%$, 1/8W)

VALUE	VALUE
71.5K	39.2K
66.5K	33.2K
61.9K	26.7K
56.2K	20.5K
51.1K	14.0K
43.3K	7.15K

dc. Place the resistor in the socket for R19 if the DVM reads positive, R34 if the reading is negative

8. Adjust R26 for a DVM reading of less than 1 mV dc at TP3.
9. Perform the complete instrument calibration.

Table 4-12. R19/R34, R66/R76 Resistive Values (mF, $\pm 1\%$, 1/8W)

VALUE	VALUE
332K	48.7K
169K	43.2K
115K	38.3K
86.6K	34.8K
68.1K	31.6K
57.6K	

Section 5

List of Replaceable Parts

TABLE OF CONTENTS

TITLE	TABLE	PAGE	FIGURE	PAGE
8920A 8921A Final Assembly	5-1	5-3	5-1	5-4
A1 8920A Main PCB Assembly	5-2	5-5	5-2	5-9
A1 8921A Main PCB Assembly	5-3	5-11	5-3	5-15
A1A1 Display PCB Assembly	5-4	5-17	5-4	5-17
A2 8920A 8921A AC PCB Assembly	5-5	5-18	5-5	5-24

5-1. INTRODUCTION

5-2. This section contains an illustrated parts breakdown of the instrument (8920A/8921A). Components are listed alpha-numerically by assembly. Electrical components are listed by reference designation and mechanical components by item number. Each listed part is shown in an accompanying illustration.

5-3. Parts lists include the following information:

1. Reference Designation or Item number.
2. Description of each part.
3. Fluke Stock number.
4. Manufacturer's part number or type.
5. Total quantity per assembly or component.
6. Recommended quantity: this indicates the recommended number of spare parts necessary to support one to five instruments for a period of two years. This list presumes an availability of common electronic parts at the maintenance site. For maintenance for one year or more at an isolated site, it is recommended that at least one of each assembly in the instrument be stocked. In the case of optional subassemblies, plug-ins, etc. that are

not always part of the instrument, or are deviations from the basic instrument model, the REC QTY column lists the recommended quantity of the item in that particular assembly.

5-4. HOW TO OBTAIN PARTS

5-5. Components may be ordered from the nearest Fluke authorized service center listed at the rear of this manual. To ensure prompt and efficient handling of your order, include the following information:

1. Quantity.
2. FLUKE stock number.
3. Description.
4. Reference designation or Item number.
5. Printed circuit board part number and rev letter.
6. Instrument model and serial number.

CAUTION



The above symbol indicates devices are subject to damage by static discharge.

Table 5-1. 8920A/8921A Final Assembly

ITEM NO.	DESCRIPTION	FLUKE STOCK NO.	MFG SPLY CODE	MFG PART NO. OR TYPE	TOT QTY	REC QTY	USE CDE
A1	MODEL 8920A/8921A FINAL ASSEMBLY ⊗ MAIN PCB ASSEMBLY	ORDER	MODEL	8920A OR 8921A			
	8920A (8920A-4001) FIGURE 5-2	ORDER	MODEL	8920A	1		
	8921A (8921A-4011) FIGURE 5-3	ORDER	MODEL	8921A			
A2	AC PCB ASSY.(8920A/8921A)FIG. 5-5	489369	89526	489369	1		
H1	SCREW,FHP,6-32 X 3/4	114504	89536	114504	4		
H2	SCREW, PHP, 2-56 X 1/4	149534	73734	19002	2		
H3	SCREW 4-40 X 1/4 PHP	256156	73734	23022	14		
H4	SCREW 6-32 X 5/8 FHP	335158	89536	335158	2		
MP1	GUARD COVER, C SIZE	464115	89536	464115	1		
MP2	COVER, PLATE DOU	456764	89536	456764	1		
MP3	BAIL	467555	89536	467555	1		
MP4	RETAINER, HANDLE	467563	89536	467563	1		
MP5	DECAL, RETAINER	473645	89536	473645	1		
MP6	COVER, C SIZE	454736	89536	454736	1		
MP7	HANDLE	454751	89536	454751	1		
MP8	COVER, AC SHIELD	456848	89536	456848	1		
MP9	LINE CORD (NOT SHOWN)	343723	89536	343723	1		
MP10	SOLDER LUG,11/16 LG,#9(8921A ONLY)	101055	79963	9	1		
MP11	SOLDER LUG,7/8 LG,#141(8920A ONLY)	104091	79963	141	1		
R1	SEE "RMS SENSOR REPLACEMENT"PROCEDURE.			SECTION 4	1		1
R204	SEE "A/D CALIBRATION RESISTOR SELECTION"			SECTION 4	1		
R3	SEE "DC OFFSET RESISTOR SELECTION".			SECTION 4	1		2

1 R1 IS A RESISTOR SET,(R97,R105,R96/R110

2 R3 IS A RESISTOR SET,(R19/R34, R66/R76

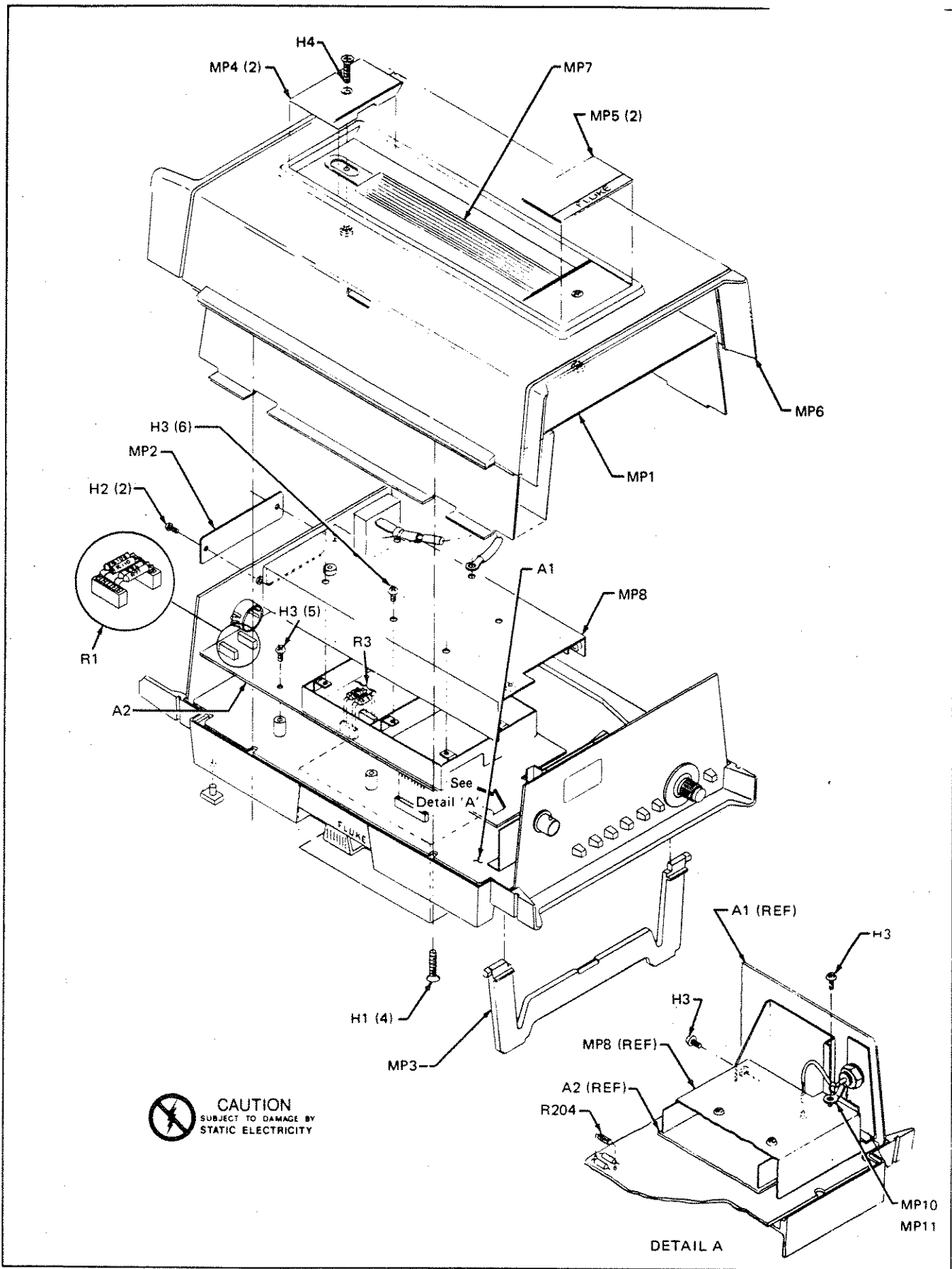

Figure 5-1. 8920A/8921A Final Assembly

Table 5-2. A1 8920A Main PCB Assembly

ITEM NO.	DESCRIPTION	FLUKE STOCK NO.	MFG SPLY CODE	MFG PART NO. OR TYPE	TOT QTY	REC QTY	USE CODE
A1	⊗ MAIN PCB ASSEMBLY(8920A-4001)FIG.5-2	ORDER	MODEL	8920A	1		
A1A1	DISPLAY PCB ASSEMBLY(8920A/8921A)FIG.5-4	ORDER	MODEL	8920A OR 8921A	1		
C200	CAP,PLYPRP,0.47 UF +/-10%,100V	446807	89536	446807	1		
C201	CAP,TA,0.47 UF +/-20%,35V	161349	56289	196D474X0035HA1	1		
C202	CAP,MICA,150 PF +/-5%,500V	148478	72136	DMF15151J	1		
C203	CAP,PLYSTR,0.22 UF +/-10%,100V	436113	73445	C280MAH/220K	1		
C204	CAP,CER,10,000 PF +/-20%,100V	149153	56289	C023B10F103M	4		
C205	CAP,CER,10,000 PF +/-20%,100V	149153	56289	C023B10F103M	REF		
C206	CAP, MICA, 470 PF +/-5%,500V	148429	72136	DMF19471J	1		
C207	CAP,MICA,3000 PF +/-5%,500V	161786	72136	DMF19302J	1		
C208	CAP,ELECT,220 UF -10/+75%,35V	460279	89536	460279	3	1	
C209	CAP,ELECT,220 UF -10/+75%,35V	460279	89536	460279	REF		
C210	CAP,ELECT,220 UF -10/+75%,35V	460279	89536	460279	REF		
C211	CAP,ELECT,4700 UF -10/+100%,15V	460261	80031	3143TS502V015	1	1	
C212	CAP,CER,10,000 PF +/-20%,100V	149153	56289	C023B10F103M	REF		
C213	CAP,CER,10,000 PF +/-20%,100V	149153	56289	C023B10F103M	REF		
CR1	RECTIFIER BRIDGE, 50V, 25A	473520	21845	J775-OLP	1		
CR200	DIODE,MULTI-PELLET	375477	09214	MPD200	1	1	
CR201	DIODE,HI-SPEED SW	203323	07910	IN4448	5	1	
CR202	DIODE,HI-SPEED SW	203323	07910	IN4448	REF		
CR203	DIODE,HI-SPEED SW	203323	07910	IN4448	REF		
CR204	RECTIFIER BRIDGE	296509	21845	F903C-22	2	1	
CR205	RECTIFIER BRIDGE	296509	21845	F903C-22	REF		
CR206	DIODE,HI-SPEED SW	203323	07910	IN4448	REF		
CR207	DIODE,HI-SPEED SW	203323	07910	IN4448	REF		
F1	FUSE, SLO-BLO	166488	71400	MDL1-8	1		
H200	SCREW, ST. RHP, 4-40 X 1/4	256156	73734	22022	10		
H201	WASHER, LOCK, STEEL F/#4	110395	73734	1355	2		
H202	NUT, 4-40 HEX, STEEL	184044	73734	8002A-NP	2		
H203	SCREW,PHP 6-32,THD 5/8 L	152181	73734	19047	1		
H204	NUT,6-32 LOCKING HEX STEEL	152819	78199	511-061800-00	1		
J1	CONNECTOR BANANA JACK BLACK	162073	74970	108-0903-001	1		
J2	CONNECTOR BANANA JACK, RED	162065	74970	108-0902-001	1		
J6	CONNECTOR,FEMALE BNC,8920A ONLY	414201	02660	31-010	1		
J101	SOCKET,IN-LINE	436774	60065	SS-109-1-04	3		
J102	SOCKET,IN-LINE	436774	60065	SS-109-1-04	REF		
J103	SOCKET,IN-LINE	436774	60065	SS-109-1-04	REF		
J203	CONN,AC,PWR	461806	89536	461806	1		
J301	CONN,MATING	461095	00779	87406-1	1		
J401	POST,CNTACT	417329	22526	65500-104	1		
J501	POST,CNTACT	474213	22526	65500-1081	1		
J601	POST,CNTACT	478693	22526	65500-110	1		
L200	CHOKE,6 TURN	320911	89536	320911	1		
L201	CHOKE,RF	186288	72259	WEE390	1		
M1	METER,ANALOG PANEL	478685	32171	OMC-DMA-001-CP2	1		
MP1	BRACKET, SWITCH MOUNTING	475392	89536	475392	1		
MP203	BRACKET, METER MOUNTING	468868	89536	468868	1		
MP204	BRACKET,PUSH RCD	456749	89536	456749	1		
MP205	KNOB,SKIRTED	463224	89536	463224	1		
MP206	SHIELD, TRANSFORMER	467696	89536	467696	1		

Table 5-2. A1 8920A Main PCB Assembly (cont)

ITEM NO.	DESCRIPTION	FLUKE STOCK NO.	MFG SPLY CODE	MFG PART NO. OR TYPE	TOT QTY	REC QTY	USE CDE
MP207	BRACKET, FRONT PANEL	467704	89536	467704	1		
MP208	PANEL, REAR	456780	89536	456780	1		
MP209	PUSH ROD, POWER SWITCH	456731	89536	456731	1		
MP210	COVER, AC SWITCH	475681	89536	475681	1		
MP228	GUARD, BASE	464404	89536	464404	1		
MP229	LATCH, PTI	467548	89536	467548	2		
MP231	DECAL, KNOB	473546	89536	473546	1		
MP232	SPECIFICATION DECAL	473611	89536	473611	1		
MP233	PANEL, FRONT	453175	89536	453175	1		
MP234	DECAL, BASE SIDES	473652	89536	473652	2		
MP235	BASE, STANDARD	454702	89536	454702	1		
MP236	HOLE, PLUG	407502	89536	407502	1		
Q200	XSTR, SI, PNP	340026	89536	340026	5	1	
Q201	XSTR, SI, PNP	340026	89536	340026	REF		
Q202	XSTR, SI, PNP	340026	89536	340026	REF		
Q203	XSTR, SI, PNP	340026	89536	340026	REF		
Q204	XSTR, SI, PNP	340026	89536	340026	REF		
Q205	XSTR, SI, NPN	218396	04713	2N3904	2	1	
Q206	XSTR, SI, NPN	218396	04713	2N3904	REF		
Q207	XSTR, SI, PNP PWR	325753	03508	D45C5	1	1	
Q208	XSTR, FET, GRP N-CHANNEL	261388	89536	261388	2	1	
Q209	XSTR, FET, GRP N-CHANNEL	261388	89536	261388	REF		
R200	RES, COMP, 100K +/-5%, 1/4W	148189	01121	CB1045	3	1	
R201	RES, MTLFLM, 2.15K +/-1%, 1/8W	293712	91637	CMF552151F	1		
R202	RES, MTLFLM, 301K +/-1%, 1/8W	379156	91637	CMF553013F	1		
R203	RES, COMP, 1M +/-5%, 1/4W	182204	01121	CB1055	3		
R205	RES, VAR, CER, 10K +/-10%, 1/2W	309674	89536	309674	2	1	
R206	RES, MTLFLM, 499K +/-1%, 1/8W	349191	91637	CMF554993F	1		
R207	RES, MTLFLM, 47.5K +/-1%, 1/8W	474585	91637	CMF554752F	1		
R208	RES, COMP 10K +/-5%, 1/4W	148106	01121	CB1035	3		
R209	RES, COMP 68K +/-5%, 1/4W	148171	01121	CB6835	1		
R210	RES, COMP, 150 +/-5%, 1/4W	147934	01121	CB1515	2		
R212	RES, COMP, 22K +/-5%, 1/4W	148130	01121	CB2235	1		
R213	RES, COMP 10K +/-5%, 1/4W	148106	01121	CB1035	REF		
R214	RES, COMP, 330K +/-5%, 1/4W	192948	01121	CB3345	1		
R215	RES, COMP 10K +/-5%, 1/4W	148106	01121	CB1035	REF		
R216	RES, COMP, 6.8K +/-5%, 1/4W	148098	01121	CB62825	1		
R217	RES, COMP, 22K +/-5%, 1/4W	148130	01121	CB2235	1		
R218	RES, COMP, 100K +/-5%, 1/4W	148189	01121	CB1045	REF		
R219	RES, COMP, 1K, +/-5%, 1/4W	148023	01121	CB1025	2		
R220	RES, COMP, 20K +/-5%, 1/4W	221614	01121	CB2035	3		
R221	RES, COMP, 20K +/-5%, 1/4W	221614	01121	CB2035	REF		
R222	RES, COMP, 1K, +/-5%, 1/4W	148023	01121	CB1025	REF		
R223	RES, COMP, 20K +/-5%, 1/4W	221614	01121	CB2035	REF		
R224	RES, VAR, CER, 10K +/-10%, 1/2W	309674	89536	309674	REF		
R225	RES, MTLFLM, 90.9K +/-1%, 1/8W	223537	91637	CMF559092F	1		
R226	RES, MTLFLM, 953 +/-1%, 1/8W	288555	91637	CMF559530F	1		
R227	RES, MTLFLM, 909 +/-1%, 1/8W	312629	91637	CMF559090F	1		
R228	RES, MTLFLM, 8.66K +/-1%, 1/8W	260364	91637	CMF558661F	1		
R229	RES, VAR, CER, 2K +/-10%, 1/2W	309666	89536	309666	1	1	

Table 5-2. A1 8920A Main PCB Assembly (cont)

ITEM NO.	DESCRIPTION	FLUKE STOCK NO.	MFG SPLY CODE	MFG PART NO. OR TYPE	TOT QTY	REC QTY	USE CDE
R230	RES,COMP,1M +/-5%,1/4W	182204	01121	CB1055	REF		
R231	RES,MTLFLM,11.8K +/-0.25%,1/8W	325688	91637	CMF551182F	2		
R232	RES,MTLFLM,11.8K +/-0.25%,1/8W	325688	91637	CMF551182F	REF		
R234	RES,VAR,CER,100K +/-10%,1/2W	369520	89536	369520	1	1	
R235	RES,MTLFLM,110K +/-1%,1/8W	234708	91637	CMF551103F	1		
R236	RES,COMP,82K +/-5%,1/4W	188458	01121	CB8235	1		
R237	RES,COMP,100K +/-5%,1/4W	148189	01121	CB1045	REF		
R238	RES,MTLFLM,100K +/-1%,1/8W	248807	91637	CMF551003F	1		
R239	RES,COMP,150 +/-5%,1/4W	147934	01121	CB1515	REF		
R240	RES,COMP,1M +/-5%,1/4W	182204	01121	CB1055	REF		
R241	RES,COMP,1M +/-5%,1/4W	182204	01121	CB1055	REF		
S201-1	BUTTON,RANGE	426759	89536	426759	3		
S201-206	SWITCH, SET	453662	89536	453662	1		
S202-1	BUTTON,FUNCTION	425900	89536	425900	3		
S203-1	BUTTON,FUNCTION	425900	89536	425900	REF		
S204-1	BUTTON,FUNCTION	425900	89536	425900	REF		
S205-1	BUTTON,RANGE	426759	89536	426759	REF		
S206-1	BUTTON,RANGE	426759	89536	426759	REF		
S207	SWITCH, ROTARY	453670	89536	453670	1		
S208	SWITCH, POWER	453605	89536	453605	1		
S208-1	BUTTON SWITCH, GREEN	445197	89536	445197	1		
S209	SWITCH SLIDE	234278	82389	XW1659	2		
S210	SWITCH SLIDE	234278	82389	XW1659	REF		
T200	POWER TRANSFORMER	458349	89536	458349	1		
U200	⊗ IC, C-MOS, QUAD BI-LATERAL SW.	363838	02735	CD4016AE	1		
U201	IC, LIN, OP-AMP	428862	02735	CA3130	1	1	
U202	IC, LIN, 5 XSTR,ARRAY 2-PNP,3NPN	418954	02735	CA30963E	1	1	
U203	⊗ IC,C-MOS,HEX BUFFER/	381848	02735	CD4049AE	2	1	
U204	⊗ IC,C-MOS,QUAD 2-INPUT NAND GATE	355198	02735	CD4011AE	1	1	
U205	8920 CUSTOM LSI	458463	89536	458463	1		
U206	IC,LIN,NPN XSTR.ARRAY	419002	02735	CA3086E	1	1	
U207	⊗ IC,C-MOS,HEX BUFFER/	381848	02735	CD4049AE	REF		
U209	⊗ IC,C-MOS,HEX INVERTER	404681	02735	CD4069UBE	1	1	
U210	IC,LIN,OP-AMP	418566	18324	LM358/CR999	1	1	
U211	IC,LIN,OP-AMP	413740	18324	LM307N	1	1	
VR201	DIODE,ZENER,6.4V	381988	04713	SZG20120	1	1	
VR202	IC,LIN,ADJ-REG	460410	12040	LM317T	1	1	
VR203	IC,LINEAR,VOL-REG	355107	07236	F78050C	1	1	
VR204	DIODE, ZENER	159798	07910	IN751A	1	1	
W1	WIRE ASSY, FRONT PANEL	486654	89536	486654	1		
W2	WIRE ASSY, FRONT PANEL	486662	89536	476662	1		
W5	WIRE ASSY, FRONT PANEL	486605	89536	486605	1		
W6	WIRE ASSY,FUSE	486621	89536	486621	2		
W7	WIRE ASSY, FUSE	486621	89536	486621	REF		
W10	GROUND STRAP ASSY, BRIDGE RECTIFIER	486647	89536	486647	1		
W11	WIRE ASSY, BRIDGE RECTIFIER	486639	89536	486639	1		
W201	WIRE ASSY, JUMPER	486613	89536	486613	1		
XF1	HOLDER, FUSE	375188	89536	375188	1		
XF1-1	FUSEHOLDER CAP, GREY, 1/4" X 1-1/4"	460238	89536	460238	1		
XR204	SOCKET, RESISTOR	343285	0779	2-33127-6	2		

Table 5-2. A1 8920A Main PCB Assembly (cont)

ITEM NO.	DESCRIPTION	FLUKE STOCK NO.	MFG SPLY CODE	MFG PART NO. OR TYPE	TOT QTY	REC QTY	USE CDE
XU200	SOCKET,IC 14 PINS(NOT SHOWN)	370304	01295	C931402			
XU202	SOCKET,IC(NOT SHOWN)	343285	00779	2-331271-6	1		
XU203	SOCKET,IC(NOT SHOWN)	343285	00779	2-331271-6	2		
XU205	SOCKET,IC,40 PINS	429282	09922	DILB40P-108	REF		
					1		

 IF VR201 IS REPLACED THE A/D CALIBRATION RESISTOR (R204) MAY HAVE TO BE RESELECTED,SEE SECTION 4 "A/D CALIBRATION RESISTOR SELECTION".

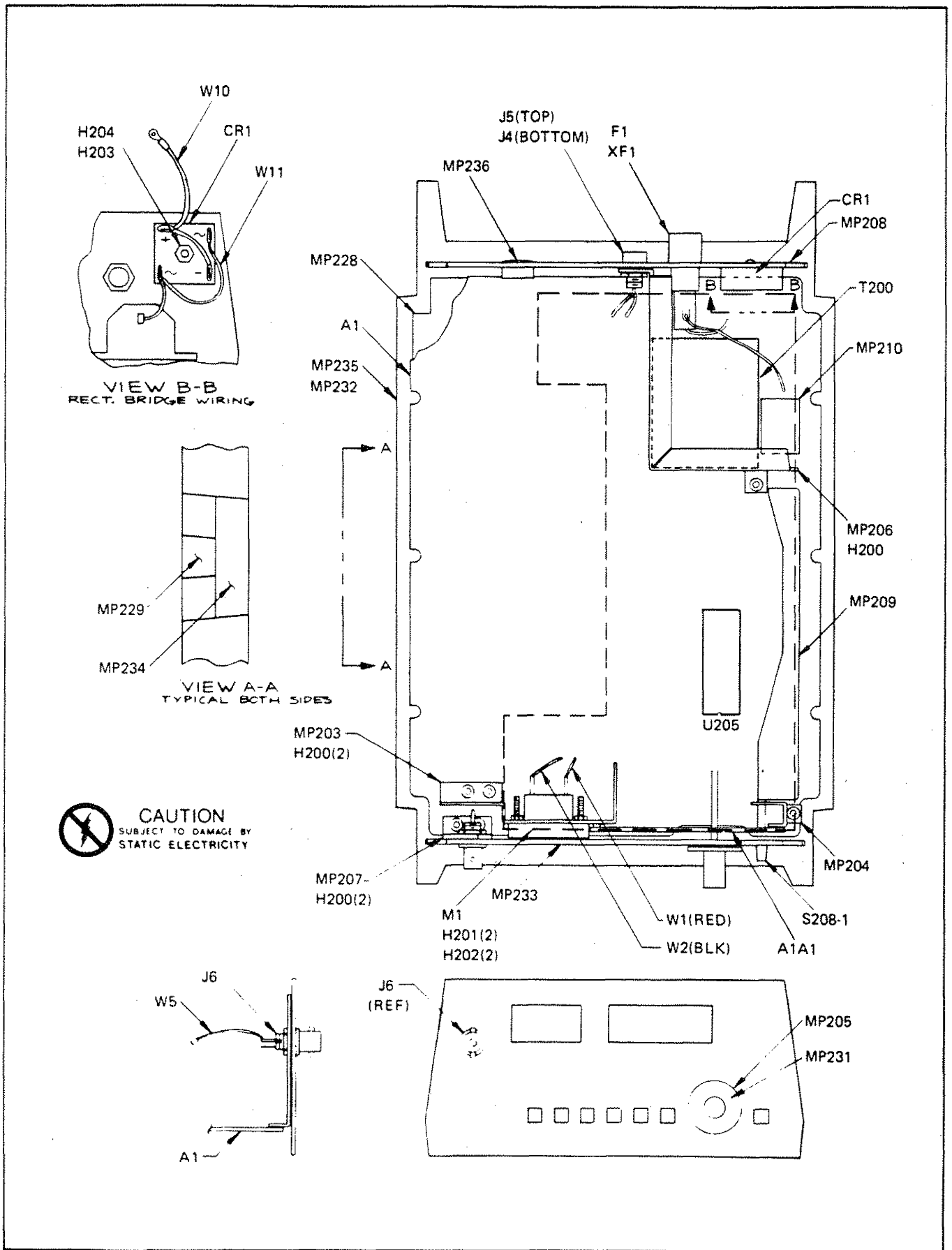

Figure 5-2. A1 8920A Main PCB Assembly

Table 5-3. A1 8921A Main PCB Assembly (cont)

ITEM NO.	DESCRIPTION	FLUKE STOCK NO.	MFG SPLY CODE	MFG PART NO. OR TYPE	TOT QTY	REC QTY	USE CDE
R227	RES,MTLFLM ,909 +/-1%,1/8W	312629	91637	CMF559090F	1		
R228	RES,MTLFLM,8.66K +/-1%,1/8W	260364	91637	CMF558661F	1		
R229	RES,VAR,CER,2K +/-10%,1/2W	309666	89536	309666	1	1	
R230	RES,COMP,1M +/-5%,1/4W	182204	01121	CB1055	REF		
R231	RES,MTLFLM,11.8K +/-0.25%,1/8W	325688	91637	CMF551182F	2		
R232	RES,MTLFLM,11.8K +/-0.25%,1/8W	325688	91637	CMF551182F	REF		
R234	RES,VAR,CER,100K +/-10%,1/2W	369520	89536	369520	1	1	
R235	RES,MTLFLM,110K +/-1%,1/8W	234708	91637	CMF551103F	1		
R236	RES,COMP,82K +/-5%,1/4W	188458	01121	CB8235	1		
R237	RES,COMP,100K +/-5%,1/4W	148189	01121	CB1045	REF		
R238	RES,MTLFLM,100K +/-1%,1/8W	248807	91637	CMF551003F	1		
R239	RES,COMP,150 +/-5%,1/4W	147934	01121	CB1515	REF		
R240	RES,COMP,1M +/-5%,1/4W	182204	01121	CB1055	REF		
R241	RES,COMP,1M +/-5%,1/4W	182204	01121	CB1055	REF		
S201-1	BUTTON,RANGE	426759	89536	426759	3		
S201-206	SWITCH, SET	453662	89536	453662	1		
S202-1	BUTTON,FUNCTION	425900	89536	425900	3		
S203-1	BUTTON,FUNCTION	425900	89536	425900	REF		
S204-1	BUTTON,FUNCTION	425900	89536	425900	REF		
S205-1	BUTTON,RANGE	426759	89536	426759	REF		
S206-1	BUTTON,RANGE	426759	89536	426759	REF		
S207	SWITCH, ROTARY	453670	89536	453670	1		
S208	SWITCH, POWER	453605	89536	453605	1		
S208-1	BUTTON SWITCH, GREEN	445197	89536	445197	1		
S209	SWITCH SLIDE	234278	82389	XW1659	2		
S210	SWITCH SLIDE	234278	82389	XW1659	REF		
T200	POWER TRANSFORMER	458349	89536	458349	1		
U200	⊗ IC, C-MOS, QUAD BI-LATERAL SW.	363838	02735	CD4016AE	1		
U201	IC, LIN, OP-AMP	428862	02735	CA3130	1	1	
U202	IC, LIN, 5 XSTR,ARRAY 2-PNP,3NPN	418954	02735	CA30963E	1	1	
U203	⊗ IC,C-MOS,HEX BUFFER/	381848	02735	CD4049AE	2	1	
U204	⊗ IC,C-MOS,QUAD 2-INPUT NAND GATE	355198	02735	CD4011AE	1	1	
U205	8920 CUSTOM LSI	458463	89536	458463	1		
U206	IC,LIN,NPN XSTR.ARRAY	419002	02735	CA3086E	1	1	
U207	⊗ IC,C-MOS,HEX BUFFER/	381848	02735	CD4049AE	REF		
U209	⊗ IC,C-MOS,HEX INVERTER	404681	02735	CD4069UBE	1	1	
U210	IC,LIN,OP-AMP	418566	18324	LM358/CR999	1	1	
U211	IC,LIN,OP-AMP	413740	18324	LM307N	1	1	
VR201	DIODE,ZENER,6.4V	381988	04713	SZG20120	1	1	
VR202	IC,LIN,ADJ-REG	460410	12040	LM317T	1	1	
VR203	IC.LINEAR,VOL-REG	355107	07236	F78050C	1	1	
VR204	DIODE, ZENER	159798	07910	IN751A	1	1	
W1	WIRE ASSY, FRONT PANEL	486654	89536	486654	1		
W2	WIRE ASSY, FRONT PANEL	486662	89536	476662	1		
W5	WIRE ASSY, FRONT PANEL	486605	89536	486605	1		
W6	WIRE ASSY,FUSE	486621	89536	486621	2		
W7	WIRE ASSY, FUSE	486621	89536	486621	REF		
W201	WIRE ASSY, JUMPER	486613	89536	486613	1		
XF1	HOLDER, FUSE	375188	89536	375188	1		
XF1-1	FUSEHOLDER CAP, GREY 1/4" X 1-1/4"	460238	89536	460238	1		

Table 5-3. A1 8921A Main PCB Assembly (cont)

ITEM NO.	DESCRIPTION	FLUKE STOCK NO.	MFG SPLY CODE	MFG PART NO. OR TYPE	TOT QTY	REC QTY	USE CDE
XR204	SOCKET,RESISTOR	343285	0779	2-33127-6	2		
XU200	SOCKET, IC 14 PINS(NOT SHOWN)	370304	01295	C931402	1		
XU202	SOCKET,IC(NOT SHOWN)	343285	00779	2-331271-6	2		
XU203	SOCKET,IC(NOT SHOWN)	343285	00779	2-331271-6	REF		
XU205	SOCKET,IC,40 PINS(NOT SHOWN)	429282	09922	DILB40P-108	1		

1 IF VR201 IS REPLACED THE A/D CALIBRATION RESISTOR (R204) MAY HAVE TO BE RESELECTED,SEE SECTION 4 "A/D CALABRATION RESISTOR SELECTION".

Table 5-3. A1 8921A Main PCB Assembly

ITEM NO.	DESCRIPTION	FLUKE STOCK NO.	MFG SPLY CODE	MFG PART NO. OR TYPE	TOT QTY	REC QTY	USE CODE
A1	② MAIN PCB ASSY, (8921A-4011) FIG. 5-3	ORDER	MODEL	8921A	1		
A1A1	DISPLAY PCB ASSEMBLY (8920A/8921A) FIG. 5-4	ORDER	MODEL	8920A OR 8921A	1		
C200	CAP, PLYPRP, 0.47 UF +/-10%, 100V	446807	89536	446807	1		
C201	CAP, TA, 0.47 UF +/-20%, 35V	161349	56289	196D474X0035HA1	1		
C202	CAP, MICA, 150 PF +/-5%, 500V	148478	72136	DMF15151J	1		
C203	CAP, PLYSTR, 0.22 UF +/-10%, 100V	436113	73445	C280MAH/220K	1		
C204	CAP, CER, 10,000 PF +/-20%, 100V	149153	56289	C023B10F103M	3		
C205	CAP, CER, 10,000 PF +/-20%, 100V	149153	56289	C023B10F103M	REF		
C206	CAP, MICA, 470 PF +/-5%, 500V	148429	72136	DMF19471J	1		
C207	CAP, MICA, 3000 PF +/-5%, 500V	161786	72136	DMF19302J	1		
C208	CAP, ELECT, 220 UF -10/+75%, 35V	460279	89536	460279	3	1	
C209	CAP, ELECT, 220 UF -10/+75%, 35V	460279	89536	460279	REF		
C210	CAP, ELECT, 220 UF -10/+75%, 35V	460279	89536	460279	REF		
C211	CAP, ELECT, 4700 UF -10/+100%, 15V	460261	80031	3143TS502V015	1	1	
C212	CAP, CER, 10,000 PF +/-20%, 100V	149153	56289	C023B10F103M	REF		
CR200	DIODE, MULTI-PELLET	375477	09214	MPD200	1	1	
CR201	DIODE, HI-SPEED SW	203323	07910	IN4448	5	1	
CR202	DIODE, HI-SPEED SW	203323	07910	IN4448	REF		
CR203	DIODE, HI-SPEED SW	203323	07910	IN4448	REF		
CR204	RECTIFIER BRIDGE	296509	21845	F903C-22	2	1	
CR205	RECTIFIER BRIDGE	296509	21845	F903C-22	REF		
CR206	DIODE, HI-SPEED SW	203323	07910	IN4448	REF		
CR207	DIODE, HI-SPEED SW	203323	07910	IN4448	REF		
F1	FUSE, SLO-BLO	166488	71400	MDL1-8	1		
H200	SCREW, ST. RHP, 4-40 X 1/4	256156	73734	22022	10		
H201	WASHER, LOCK, STEEL F/#4	110395	73734	1355	2		
H202	NUT, 4-40 HEX, STEEL	184044	73734	8002A-NP	2		
H205	SCREW, PHP, 4-40 X 5/16 (NOT SHOWN)	152116	73734	19023	2		
H206	SCREW, PHP, 4-40 X 5/16 (NOT SHOWN)	152116	73734	19023	REF		
H207	NUT, HEX DBL CHMF (NOT SHOWN)	110635	73734	8003-NP	2		
H208	NUT, HEX DBL CHMF (NOT SHOWN)	110635	73734	8003-NP	REF		
J3	CONNECTOR BANANA JACK, GREEN	479329	74970	479329	1		
J4	CONNECTOR BANANA JACK, BLACK	162073	74970	108-0903-001	1		
J5	CONNECTOR BANANA JACK, RED	162065	74970	108-0902-001	1		
J6	BLANK JACK, BANANA, BLACK	484329	89536	484329	2		
J7	BLANK JACK, BANANA, BLACK	484329	89536	484329	REF		
J101	SOCKET, IN-LINE	436774	60065	SS-109-1-04	3		
J102	SOCKET, IN-LINE	436774	60065	SS-109-1-04	REF		
J103	SOCKET, IN-LINE	436774	60065	SS-109-1-04	REF		
J203	CONN, AC, PWR	461806	89536	461806	1		
J301	CONN, MATING	461095	00779	87406-1	1		
J401	POST, CONTACT	417329	22526	65500-104	1		
J501	POST, CONTACT	474213	22526	65500-1081	1		
J601	POST, CONTACT	478693	22526	65500-110	1		
L200	CHOKE, 6 TURN	320911	89536	320911	1		
L201	CHOKE, RF	186288	72259	WEE390	1		
M1	METER, ANALOG PANEL	478685	32171	OMC-DMA-001-CP2	1		
MP1	BRACKET, SWITCH MOUNTING	475392	89536	475392	1		
MP203	BRACKET, METER MOUNTING	468868	89536	468868	1		
MP204	BRACKET, PUSH ROD	456749	89536	456749	1		

Table 5-3. A1 8921A Main PCB Assembly (cont)

ITEM NO.	DESCRIPTION	FLUKE STOCK NO.	MFG SPLY CODE	MFG PART NO. OR TYPE	TOT QTY	REC QTY	USE CDE
MP205	KNOB, SKIRTED	463224	89536	463224	1		
MP206	SHIELD, TRANSFORMER	467696	89536	467696	1		
MP207	BRACKET, FRONT PANEL	467704	89536	467704	1		
MP208	PANEL, REAR	456756	89536	456756	1		
MP209	PUSH ROD, POWER SWITCH	456731	89536	456731	1		
MP210	COVER, AC SWITCH	475681	89536	475681	1		
MP228	GUARD, BASE	464404	89536	464404	1		
MP229	LATCH, PTI	467548	89536	467548	2		
MP230	DECAL, 8921A ONLY	483107	89536	483107	1		
MP231	DECAL, KNOB	473546	89536	473546	1		
MP232	SPECIFICATION DECAL	473611	89536	473611	1		
MP233	PANEL, FRONT	473173	89536	473173	1		
MP234	DECAL, BASE SIDES	473652	89536	473652	2		
MP235	BASE, STANDARD	454702	89536	454702	1		
MP236	HOLE, PLUG	407502	89536	407502	1		
Q200	XSTR, SI, PNP	340026	89536	340026	5	1	
Q201	XSTR, SI, PNP	340026	89536	340026	REF		
Q202	XSTR, SI, PNP	340026	89536	340026	REF		
Q203	XSTR, SI, PNP	340026	89536	340026	REF		
Q204	XSTR, SI, PNP	340026	89536	340026	REF		
Q205	XSTR, SI, NPN	218396	04713	2N3904	2	1	
Q206	XSTR, SI, NPN	218396	04713	2N3904	REF		
Q207	XSTR, SI, PNP PWR	325753	03508	D45C5	1	1	
Q208	XSTR, FET, GRP N-CHANNEL	261388	89536	261388	2	1	
Q209	XSTR, FET, GRP N-CHANNEL	261388	89536	261388	REF		
R200	RES, COMP, 100K +/-5%, 1/4W	148189	01121	CB1045	3	1	
R201	RES, MTLFLM, 2.15K +/-1%, 1/8W	293712	91637	CMF552151F	1		
R202	RES, MTLFLM, 301K +/-1%, 1/8W	379156	91637	CMF553013F	1		
R203	RES, COMP, 1M +/-5%, 1/4W	182204	01121	CB1055	3		
R205	RES, VAR, CER, 10K +/-10%, 1/2W	309674	89536	309674	2	1	
R206	RES, MTLFLM, 499K +/-1%, 1/8W	349191	91637	CMF554993F	1		
R207	RES, MTLFLM, 47.5K +/-1%, 1/8W	474585	91637	CMF554752F	1		
R208	RES, COMP 10K +/-5%, 1/4W	148106	01121	CB1035	3		
R209	RES, COMP 68K +/-5%, 1/4W	148171	01121	CB6835		1	
R210	RES, COMP, 150 +/-5%, 1/4W	147934	01121	CB1515	2		
R212	RES, COMP, 22K +/-5%, 1/4W	148130	01121	CB2235	1		
R213	RES, COMP 10K +/-5%, 1/4W	148106	01121	CB1035	REF		
R214	RES, COMP, 330K +/-5%, 1/4W	192948	01121	CB3345	1		
R215	RES, COMP 10K +/-5%, 1/4W	148106	01121	CB1035	REF		
R216	RES, COMP, 6.8K +/-5%, 1/4W	148098	01121	CB62825	1		
R217	RES, COMP, 22K +/-5%, 1/4W	148130	01121	CB2235	1		
R218	RES, COMP, 100K +/-5%, 1/4W	148189	01121	CB1045	REF		
R219	RES, COMP, 1K, +/-5%, 1/4W	148023	01121	CB1025	2		
R220	RES, COMP, 20K +/-5%, 1/4W	221614	01121	CB2035	3		
R221	RES, COMP, 20K +/-5%, 1/4W	221614	01121	CB2035	REF		
R222	RES, COMP, 1K, +/-5%, 1/4W	148023	01121	CB1025	REF		
R223	RES, COMP, 20K +/-5%, 1/4W	221614	01121	CB2035	REF		
R224	RES, VAR, CER, 10K +/-10%, 1/2W	309674	89536	309674	REF		
R225	RES, MTLFLM, 90.9K +/-1%, 1/8W	223537	91637	CMF559092F	1		
R226	RES, MTLFLM, 953 +/-1%, 1/8W	288555	91637	CMF559530F	1		

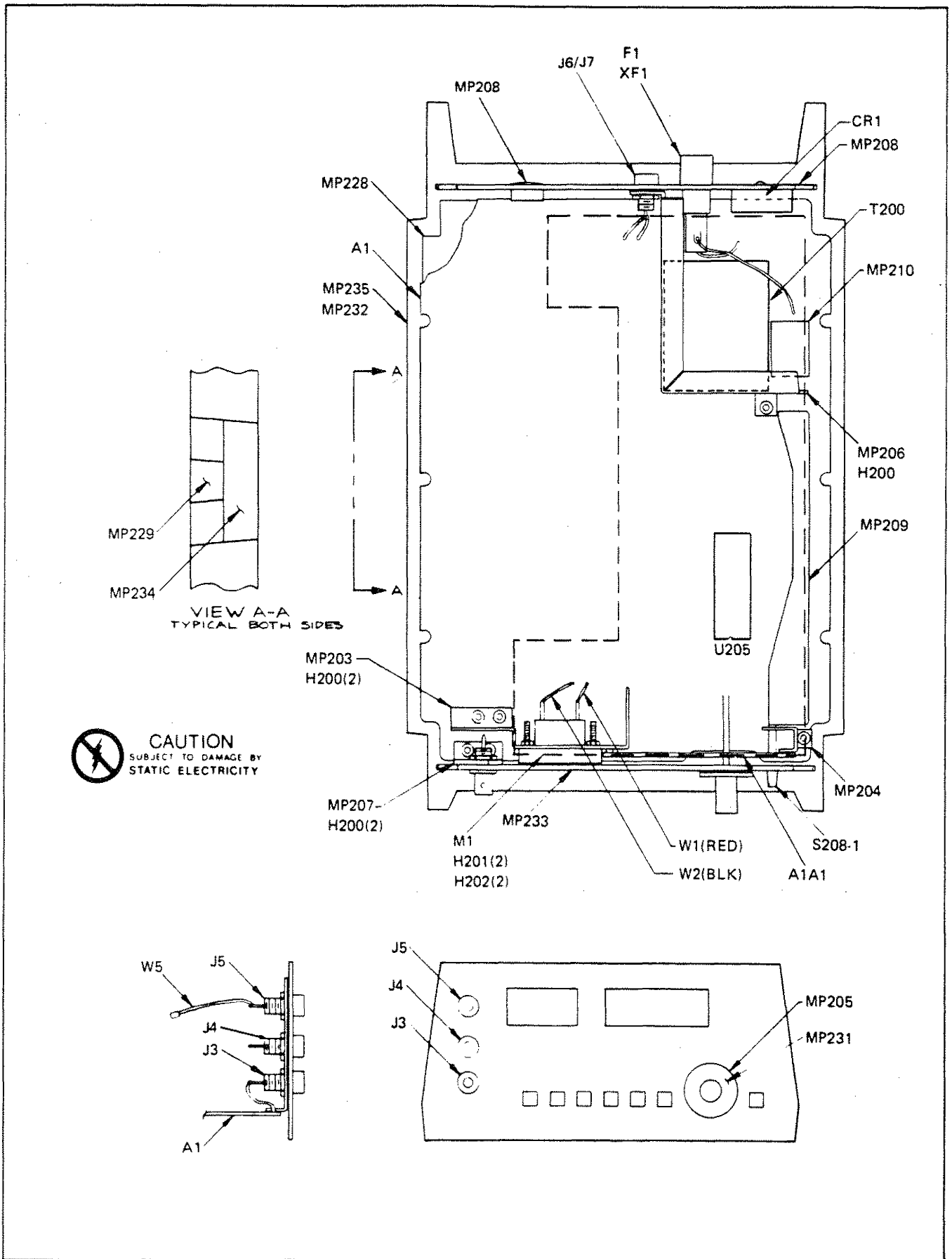

Figure 5-3. A1 8921A Main PCB Assembly

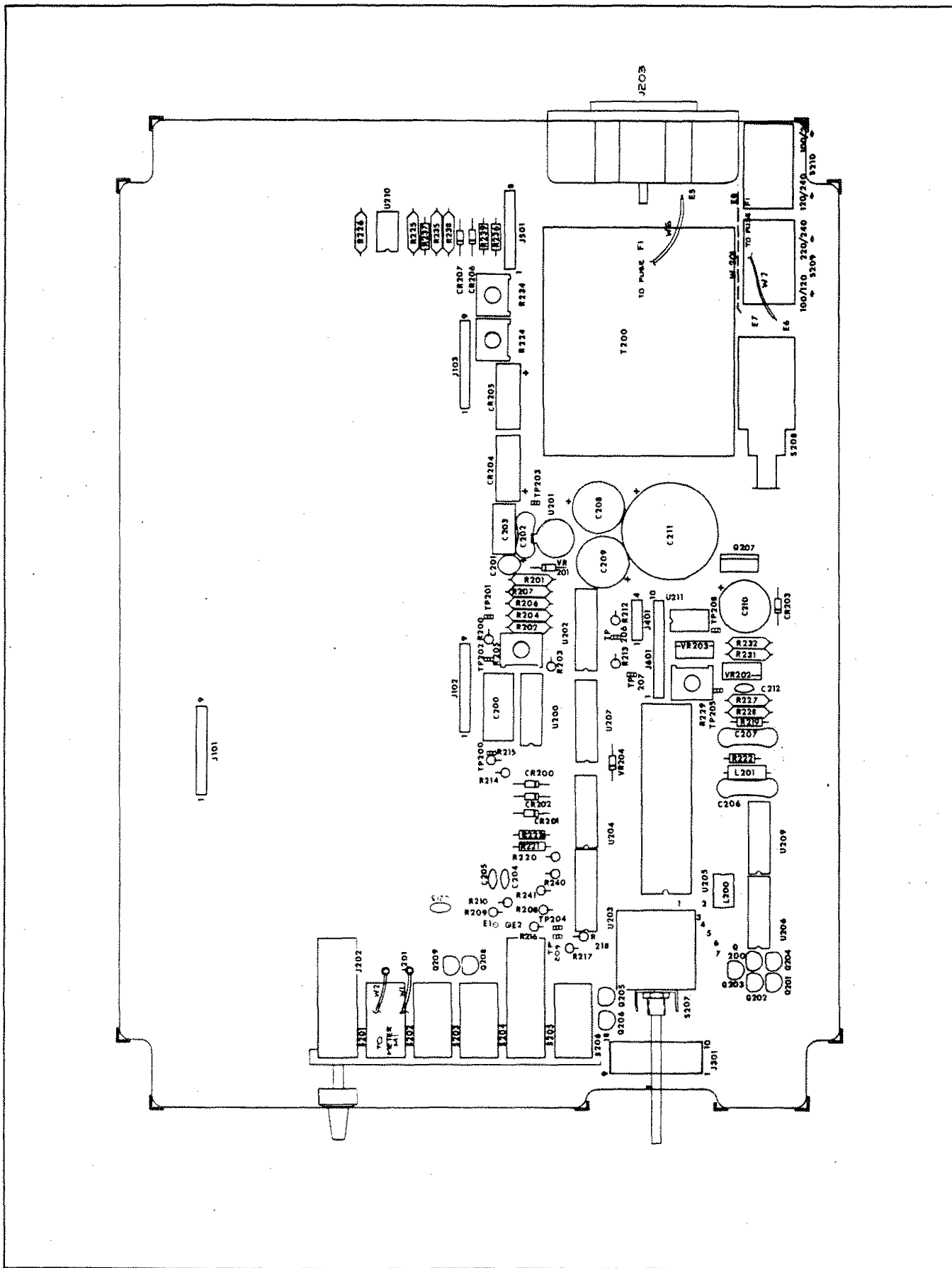

Figure 5-3. A1 8921A Main PCB Assembly (cont)

Table 5-4. A1A1 Display PCB Assembly

ITEM NO.	DESCRIPTION	FLUKE STOCK NO.	MFG SPLY CODE	MFG PART NO. OR TYPE	TOT QTY	REC QTY	USE CDE
A1A1	DISPLAY PCB ASSY (20A/21A-4002T) FIG.5-4	ORDER	MODEL	8920A OR 8921A	1		
C301	CAP,TA,1UF +/-20%,35V	161919	56289	196D105X0035JA1	1		
CR301	DIODE,HI-SPEED SWITCH	203323	07910	1N4448	1	1	
DS301	DISPLAY,LED	495457	29083	QDSP3507	1		
DS302	DISPLAY,LED	495440	28480	QDSP3515	4		
DS303	DISPLAY,LED	495440	28480	QDSP3515	REF		
DS304	DISPLAY,LED	495440	28480	QDSP3515	REF		
DS305	DISPLAY,LED	495440	28480	QDSP3515	REF		
DS306	DIODE,LIGHT EMMITING	385898	28480	5082-4887	5		
DS307	DIODE,LIGHT EMMITING	385898	28480	5082-4887	REF		
DS308	DIODE,LIGHT EMMITING	385898	28480	5082-4887	REF		
DS309	DIODE,LIGHT EMMITING	385898	28480	5082-4887	REF		
DS310	DIODE,LIGHT EMMITING	385898	28480	5082-4887	REF		
P301	CONN,POST	376574	00779	3-87022-1	18		
Q301	XSTR,SI,PNP	340026	89536	340026	1	1	
R301	RES,COMP,150 +/-5%,1/4W	147934	01121	CB1515	3		
R302	RES,COMP,12.7K +/-5% 1/4 W	170720	01121	CB2725	1		
R303	RES,COMP,150 +/-5%,1/4W	147934	01121	CB1515	REF		
R304	RES,COMP 15K +/-5%, 1/4W	148114	01121	CB1535	1		
R305	RES,COMP,150 +/-5%,1/4W	147934	01121	CB1515	REF		
U301	RES,NETWORK	461442	89536	461442	1	1	
U302	IC,TTL,LO-POWER,DECODER DRIVER	418632	01295	SN74L47N	1	1	

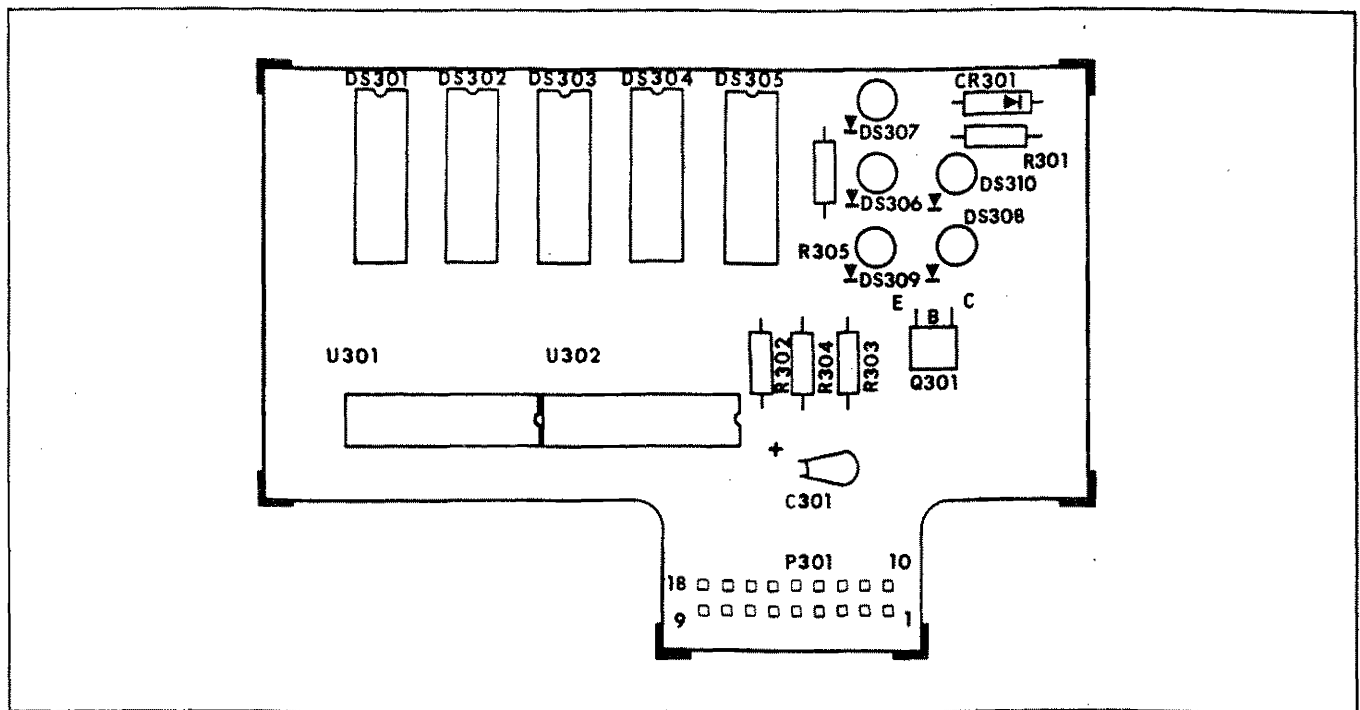

Figure 5-4. A1A1 Display PCB Assembly

Table 5-5. A2 8920A/8921A AC PCB Assembly

ITEM NO.	DESCRIPTION	FLUKE STOCK NO.	MFG SPLY CODE	MFG PART NO. OR TYPE	TOT QTY	REC QTY	USE CDE
A2	AC PCB ASSY(20A/21A-4003T)FIG.5-5	489369	89536	489369	1		
C1	CAP, FIXED, 0.022UF +/-10%, 630V	479519	73445	C280MAG/A22K	1		
C2	CAP, PORC, 180PF +/-5%, 1KV	474551	95275	VY15CA181JA	1		
C3	CAP, PORC, 4.3PF +/-0.25PF, 1.7KV	479253	95275	VY10CA4R3	1		
C4	CAP, CER, 510PF +/-5%, 100V	460832	95275	VK20BA511J	1		
C5	CAP, VAR, 1-5-0.25PF, 2000V	218206	72982	530-000	1		
C6	CAP, CER, 39PF +/-5%, 100V	460824	95275	VK20BA390J	3		
C7	CAP, CER, 5100PF +/-5%, 100V	460840	95275	VK20BA512J	1		
C8	CAP, VAR, 5.5-18PF, 350V	460170	72982	538-002	1		
C9	CAP, VAR, 1.7-6PF, 250V	460147	91293	9300	1	1	
C12	CAP, CER, 10,000 +/-20%, 100V	149153	56289	C023B101F103M	1	1	
C13	CAP, VAR, 1-5-0.25PF, 2000V	218206	72982	530-000	8		
C14	CAP, MINI CER, 1.8PF +/-0.25PF, 100V	474940	80031	2222-638-03188	2	1	
C15	CAP, CER, 50000PF -20/+80%, 25V	148924	72892	5855-000-Y5UD-503Z	1		
					2		
C16	CAP, TA, 10UF +/-20%, 20V	330662	56289	196D106X0020KA1	11		
C17	CAP, CER, 10,000 +/-20%, 100V	149153	56289	C023B101F103M	REF		
C18	CAP, TA, 1.0UF +/-20%, 35A	161919	56289	196D105X0035JA1	1		
C19	CAP, CER, 10,000 +/-20%, 100V	149153	56289	C023B101F103M	REF		
C20	CAP, TA, 10UF +/-20%, 20V	330662	56289	196D106X0020KA1	REF		
					REF		
C22	CAP, MINI-CER, 33PF +/-2%, 100V	354852	80031	2222-638-10399	2		
C23	CAP MINI-CER, 100PF +/-2%, 100V	369173	80031	2222-638-10101	1		
C24	CAP, TA, 10UF +/-20%, 20V	330662	56289	196D106X0020KA1	REF		
C25	CAP, CER, 10,000 +/-20%, 100V	149153	56289	C023B101F103M	REF		
C26	CAP, MINI-CER, 68PF +/-2%, 100V	362756	80031	2222-631-10689	1		
C28	CAP, TA, 10UF +/-20%, 20V	330662	56289	196D106X0020KA1	REF		
C29	CAP, TA, 10UF +/-20%, 20V	330662	56289	196D106X0020KA1	REF		
C31	CAP, CER, 22UF +/-20%, 50V	190314	51642	200-050-601-502M	1		
C33	CAP, VAR, 1-5-0.25PF, 2000V	218206	72982	530-000	1		
C34	CAP, TA, 10UF +/-20%, 20V	330662	56289	196D106X0020KA1	REF		
					REF		
C35	CAP, CER, 50000PF -20/+80%, 25V	148924	72892	5855-000-Y5UD-503Z	REF		
C36	CAP, CER, 10,000 +/-20%, 100V	149153	56289	C023B101F103M	REF		
C37	CAP, MINI-CER, 33PF +/-2%, 100V	354852	80031	2222-638-10399	REF		
C39	CAP, TA, 10UF +/-20%, 20V	330662	56289	196D106X0020KA1	REF		
C40	CAP, TA, 10UF +/-20%, 20V	330662	56289	196D106X0020KA1	REF		
					REF		
C41	CAP, CER, 10,000 +/-20%, 100V	149153	56289	C023B101F103M	REF		
C42	CAP, TA, 10UF +/-20%, 20V	330662	56289	196D106X0020KA1	REF		
C43	CAP, TA, 10UF +/-20%, 20V	330662	56289	196D106X0020KA1	REF		
C45	CAP, TA, 39UF +/-20%, 20V	358234	56289	196D396X0020PE4	REF		
C48	CAP, TA, 39UF +/-20%, 20V	358234	56289	196D396X0020PE4	2		
					REF		
C49	CAP, CER, 1000PF +/-10%, 500V	357806	56289	C016B102G-102K	2		
C50	CAP, CER, 10,000 +/-20%, 100V	149153	56289	C023B101F103M	REF		
C51	CAP, CER, 10,000 +/-20%, 100V	149153	56289	C023B101F103M	REF		
C53	CAP PAIR (C53 & C55)	463208	89536	463208	2		
C54	CAP, CER, 1000PF +/-10%, 500V	357806	56289	C016B102G-102K	REF		
C55	CAP PAIR (C53 & C55)	463208	89536	463208	REF		
C56	CAP, TA, 10UF +/-20%, 20V	330662	56289	196D106X0020KA1	REF		
C57	CAP, MYLAR, 0.027UF +/-10%, 250V	267120	73445	C280MAE/A47K	REF		
C58	CAP, VAR, 1.7-10, 250V	321109	91293	9301	1		
CR1	DIODE, HI-SPEED SWITCH	203323	07910	IN4448	1	1	
					7	2	

Table 5-5. A2 8920A/8921A AC PCB Assembly (cont)

ITEM NO.	DESCRIPTION	FLUKE STOCK NO.	MFG SPLY CODE	MFG PART NO. OR TYPE	TOT QTY	REC QTY	USE CDE
CR2	DIODE,HI-SPEED SWITCH	203323	07910	IN4448	REF		
CR3	DIODE,SI,LO-CAP LO-LEAK	348177	07263	FD7223	2	1	
CR4	DIODE,SI,LO-CAP LO-LEAK	348177	07263	FD7223	REF		
CR5	DIODE,HI-SPEED SWITCH	203323	07910	IN4448	REF		
CR6	DIODE,HI-SPEED SWITCH	203323	07910	IN4448	REF		
CR7	DIODE,HI-SPEED SWITCH	203323	07910	IN4448	REF		
CR8	DIODE,HI-SPEED SWITCH	203323	07910	IN4448	REF		
CR9	DIODE,HI-SPEED SWITCH	203323	07910	IN4448	REF		
J106	SOCKET,SINGLE IN-LINE,4 POST CONTACT	417311	30035	SS-109-1-04	1		
K1	COIL,REED RELAY	446898	71707	U20134	2		
K1-1	REED SWITCH	284091	95348	MR138	2		
K2	COIL,REED RELAY	446898	71707	U20134	REF		
K2-1	REED SWITCH	284091	95348	MR138	REF		
MP1	SHIELD,AC	456830	89536	456830	1		
MP183	SPACER,XSTR MNTG	472969	13103	7717-30	1		
MP202	SHIELD	456830	89536	456830	1		
MP208	THERMAL EQUALIZER	489179	89536	489179	1		
P101	POST,CONTACT	474742	22526	65500-109	3		
P102	POST,CONTACT	474742	22526	65500-109	REF		
P103	POST,CONTACT	474742	22526	65500-109	REF		
P104	CONNECTOR	485169	89536	485169	1		
Q1	XSTR,SI,NPN SELECTED	471565	89536	471565	2	1	
Q2	XSTR,SI,NPN SELECTED	471565	89536	471565	REF		
Q3	XSTR,FET,JCT,N-CHANNEL	477448	89536	477448	1	1	
Q4	XSTR,FET,JCT,N-CHANNEL	376475	89536	376475	6	2	
Q5	XSTR,FET,JCT,N-CHANNEL	376475	89536	376475	REF		
Q6	XSTR,FET,JCT,N-CHANNEL	376475	89536	376475	REF		
Q8	XSTR,SI,PNP	453829	24355	AD821	2	1	
Q9	DUAL FET/RESISTOR SET	476788	89536	476788	1	1	
Q10	XSTR, MATCHED SET	463133	89536	463133	1	1	
Q11	XSTR,SI,PNP	454066	04713	SP7755	10	2	
Q12	XSTR, MATCHED SET	463133	89536	463133	REF		
Q13	XSTR,SI NPN	333898	89536	333898	7	1	
Q14	XSTR,SI NPN	333898	89536	333898	REF		
Q15	XSTR,SI,PNP	225599	12040	PN4250	2	1	
Q16	XSTR,SI,PNP	454066	04713	SP7755	REF		
Q17	XSTR,SI NPN	333898	89536	333898	REF		
Q18	XSTR,SI,PNP	454066	04713	SP7755	REF		
Q19	XSTR,SI NPN	333898	89536	333898	REF		
Q20	XSTR,SI,PNP	454066	04713	SP7755	REF		
Q21	XSTR,SI,PNP	454066	04713	SP7755	REF		
Q23	XSTR,SI,NPN	218081	89536	218081	4	1	
Q24	XSTR,SI,PNP	229898	89536	229898	4	1	
Q25	XSTR,SI,NPN	218081	89536	218081	REF		
Q26	XSTR,SI,PNP	229898	89536	229898	REF		
Q28	XSTR,FET,JCT,N-CHANNEL	376475	89536	376475	REF		
Q29	XSTR,FET,N-CHANNEL	261578	89536	261578	3	1	
Q30	XSTR,FET,N-CHANNEL	261578	89536	261578	REF		
Q31	XSTR,FET,N-CHANNEL	261578	89536	261578	REF		
Q32	XSTR,FET,JCT,N-CHANNEL	376475	89536	376475	REF		

Table 5-5. A2 8920A/8921A AC PCB Assembly (cont)



ITEM NO.	DESCRIPTION	FLUKE STOCK NO.	MFG SPLY CODE	MFG PART NO. OR TYPE	TOT QTY	REC QTY	USE CDE
Q33	XSTR,FET,JCT,N-CHANNEL	376475	89536	376475	REF		
Q36	XSTR,SI,PNP	453829	24355	AD821	REF		
Q37	DUAL FET/RESISTOR SET	476788	89536	476788	REF		
Q38	XSTR, MATCHED SET	463133	89536	463133	REF		
Q39	XSTR,SI,PNP	454066	04713	SP7755	REF		
Q40	XSTR, MATCHED SET	463133	89536	463133	REF		
Q41	XSTR,SI,NPN	333898	89536	333898	REF		
Q42	XSTR,SI,PNP	225599	12040	PN4250	REF		
Q43	XSTR,SI,PNP	454066	04713	SP7755	REF		
Q44	XSTR,SI,NPN	333898	89536	333898	REF		
Q45	XSTR,SI,PNP	454066	04713	SP7755	REF		
Q47	XSTR,SI,NPN	333898	89536	333898	REF		
Q48	XSTR,SI,PNP	454066	04713	SP7755	REF		
Q49	XSTR,SI,PNP	454066	04713	SP7755	REF		
Q50	XSTR,SI,NPN	218081	89536	218081	REF		
Q51	XSTR,SI,PNP	229898	89536	229898	REF		
Q52	XSTR,SI,NPN	218081	89536	218081	REF		
Q53	XSTR,SI,PNP	229898	89536	229898	REF		
Q55	XSTR,SI,NPN	330803	89536	330803	1	1	
Q56	XSTR,SI,PNP	418707	07910	MPS6562	1	1	
R1	RES,MF,1M +/-1%,1/2W	161075	91637	CMF651004F	1		
R2	RES,FXD,9.91M +/-1%,1/2W	460121	91637	HFF1-9914F	1		
R3	RES,VAR,CER,5K +/-10%,1/2W	327569	89536	327569	2	1	
R4	RES,MF,96.5K +/-1%,1/8W	474478	91637	CMF559652F	1		
R5	RES,VAR,10 +/-20%,1/2W	479311	80031	ET50W100	1	1	
R6	RES,MF,1M +/-1%,1/4W	474486	91637	CMF601004F	1		
R7	RES,VAR,CER,500 +/-10%,1/2W	325613	89536	325613	2	1	
R8	RES,MF,9.76K +/-0.5%,1/8W	474460	91637	CMF559761D	1		
R9	RES,COMP,15K +/-5%,1/4W	148114	01121	CB1535	2		
R10	RES,COMP,100 +/-5%,1/4W	147926	01121	CB105	6		
R11	RES,COMP,15K +/-5%,1/4W	148114	01121	CB1535	REF		
R12	RES,CERMET,9.09M +/-1%,1/4W	459875	89536	459875	1		
R13	RES,MF,20 +/-0.5%,1/8W	494302	91637	CMF55R200D	2		
R14	RES,COMP,1M +/-5%,1/4W	182204	01121	CB1055	5		
R15	RES,COMP,6.2M +/-5%,1/4W	221960	01121	CB6255	2		
R16	RES,COMP,22M +/-5%,1/4W	221986	01121	CB2265	1		
R17	RESISTOR/DUAL FET SET	476788	89536	476788	1		
R18	RES SET (R18,R35,R65,R79)	463182	89536	463133	1		
R19	SELECTED IN TEST						
R20	RES,COMP,510 +/-5%,1/4W	218032	01121	CB5115	3		
R21	RES,COMP,390 +/-5%,1/4W	147975	01121	CB3915	4		
R22	RES,COMP,8.2K +/-5%,1/4	160796	01121	CB8225	2		
R23	RES,COMP,10K +/-5%,1/4W	148106	01121	CB1035	2		
R25	RES,MF,499K +/-1%,1/8W	268813	91637	CMF554993F	3		
R26	RES,VAR,CER,100K +/-10%,1/2W	369520	89536	369520	2	1	
R27	RES,COMP,390 +/-5%,1/4W	147975	01121	CB3915	REF		
R28	RES,MF,1.58K +/-1%,1/8W	385344	91637	CMF551581F	1		
R29	RES,COMP,100 +/-5%,1/4W	147926	01121	CB105	REF		
R30	RES,COMP,100 +/-5%,1/4W	147926	01121	CB105	REF		
R31	RES,MF,8.06K +/-1%,1/8W	294942	91637	CMF558061F	1		

Table 5-5. A2 8920A/8921A AC PCB Assembly (cont)

ITEM NO.	DESCRIPTION	FLUKE STOCK NO.	MFG SPLY CODE	MFG PART NO. OR TYPE	TOT QTY	REC QTY	USE CDE
2	<p>IF ANY ONE OF THE FOUR MATCHED XISTORS ARE DAMAGED ALL FOUR WILL HAVE TO BE REPLACED AND THE DC OFFSET RESISTORS FOR AMP-A AND AMP-B WILL HAVE TO BE RESELECTED. THEREFORE IT WILL BE NECESSARY TO ORDER TWO RESISTOR SETS SEE SECT.4"DC OFFSET RESISTOR SELECTION"</p>						
3	<p>IF THIS PART IS REPLACED THE DC OFFSET RESISTOR FOR THE CORRESPONDING AMPLIFIER (AMP-A,AMP-B)MAY HAVE TO BE RESELECTED SEE SECT.4"DC OFFSET RESISTOR SELECTION"</p>						

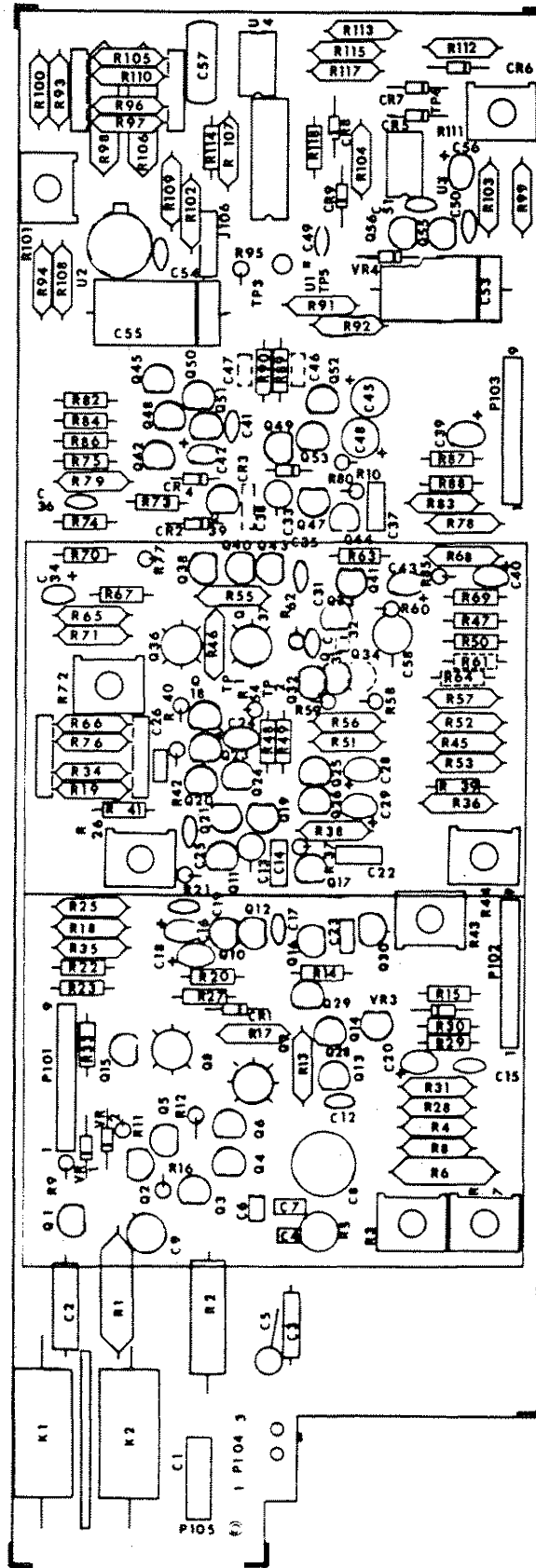



Figure 5-5. A2 8920A/8921A AC PCB Assembly

Table 5-5. A2 8920A/8921A AC PCB Assembly (cont)

ITEM NO.	DESCRIPTION	FLUKE STOCK NO.	MFG SPLY CODE	MFG PART NO. OR TYPE	TOT QTY	REC QTY	USE CDE
R33	RES,COMP,33 +/-5%,1/4W	175034	01121	CB3305	4		
R34	SELECTED IN TEST				REF		2
R35	RES SET (R18,R35,R65,R79)	463182	89536	463133	REF		
R36	RES,MF,619 +/-1%,1/8W	313072	91637	CMF556190F	4		
R37	RES,COMP,100 +/-5%,1/4W	147926	01121	CB105	REF		
R38	RES,MF,619 +/-1%,1/8W	313072	91637	CMF556190F	REF		
R39	RES,COMP,33 +/-5%,1/4W	175034	01121	CB3305	REF		
R40	RES,COMP,820 +/-5%,1/4W	148015	01121	CB8215	2		
R41	RES,COMP,22K +/-5%,1/4W	148130	01121	CB2235	2		
R42	RES,COMP,160 +/-5%,1/4W	261859	01121	CB1615	2		
R43	RES,VAR,CER,500 +/-10%,1/2W	325613	89536	325613	REF		
R44	RES,VAR,CER,50 +/-10%,1/2W	447862	89569	447862	1	1	
R45	RES,MF,121 +/-1%,1/8W	343160	91637	CMF551210F	2		
R46	RESISTOR/DUAL FET SET	476788	89536	476788	REF		2
R47	RES,COMP,300 +/-5%,1/4W	348276	01121	CB3015	4		
R48	RES,COMP,18 +/-5%,1/4W	219022	01121	CB1805	4		
R49	RES,COMP,18 +/-5%,1/4W	219022	01121	CB1805	REF		
R50	RES,COMP,300 +/-5%,1/4W	348276	01121	CB3015	REF		
R51	RES,MF,442 +/-1%,1/8W	474452	91637	CMF554420F	1		
R52	RES,MF,100 +/-1%,1/8W	474437	91637	CMF551000F	2		
R53	RES,MF,12.1 +/-1%,1/8W	296608	91637	CMF5512R1F	1		
R54	RES,COMP,1K +/-5%,1/4W	148023	01121	CB1025	2		
R55	RES,MF,20 +/-0.5%,1/8W	494302	91637	CMF55R200D	REF		2
R56	RES PAIR (R56 & R57)	467662	89536	467662	1	1	
R57	RES PAIR (R56 & R57)	467662	89536	467662	REF		
R58	RES,COMP,1M +/-5%,1/4W	182204	01121	CB1055	REF		
R59	RES,COMP,1M +/-5%,1/4W	182204	01121	CB1055	REF		
R60	RES,COMP,1M +/-5%,1/4W	182204	01121	CB1055	REF		
R62	RES,COMP,1M +/-5%,1/4W	182204	01121	CB1055	REF		
R63	RES,COMP,6.2M +/-5%,1/4W	221960	01121	CB6255	REF		
R65	RES SET (R18,R35,R65,R79)	463182	89536	463133	REF		
R66	SELECTED IN TEST				REF		2
R67	RES,COMP,510 +/-5%,1/4W	218032	01121	CB5115	REF		
R68	RES,MF,3.57K +/-1%,1/8W	226217	91637	CMF553571F	1		
R69	RES,COMP,100 +/-5%,1/4W	147926	01121	CB105	REF		
R70	RES,COMP,33 +/-5%,1/4W	175034	01121	CB3305	REF		
R71	RES,MF,499K +/-1%,1/8W	268813	91637	CMF554993F	REF		
R72	RES,VAR,CER,100K +/-10%,1/2W	369520	89536	369520	REF		
R73	RES,COMP,390 +/-5%,1/4W	147975	01121	CB3915	REF		
R74	RES,COMP,8.2K +/-5%,1/4	160796	01121	CB8225	REF		
R75	RES,COMP,10K +/-5%,1/4W	148106	01121	CB1035	REF		
R76	SELECTED IN TEST				REF		2
R77	RES,COMP,390 +/-5%,1/4W	147975	01121	CB3915	REF		
R78	RES,MF,619 +/-1%,1/8W	313072	91637	CMF556190F	REF		
R79	RES SET (R18,R35,R65,R79)	463182	89536	463133	REF		
R80	RES,COMP,100 +/-5%,1/4W	147926	01121	CB105	REF		
R82	RES,COMP,820 +/-5%,1/4W	148015	01121	CB8215	REF		
R83	RES,MF,619 +/-1%,1/8W	313072	91637	CMF556190F	REF		
R84	RES,COMP,22K +/-5%,1/4W	148130	01121	CB2235	REF		
R85	RES,COMP,33 +/-5%,1/4W	175034	01121	CB3305	REF		

Table 5-5. A2 8920A/8921A AC PCB Assembly (cont)

ITEM NO.	DESCRIPTION	FLUKE STOCK NO.	MFG SPLY CODE	MFG PART NO. OR TYPE	TOT QTY	REC QTY	USE CDE
R86	RES,COMP,160 +/-5%,1/4W	261859	01121	CB1615	REF		
R87	RES,COMP,300 +/-5%,1/4W	348276	01121	CB3015	REF		
R88	RES,COMP,300 +/-5%,1/4W	348276	01121	CB3015	REF		
R89	RES,COMP,18 +/-5%,1/4W	219022	01121	CB1805	REF		
R90	RES,COMP,18 +/-5%,1/4W	219022	01121	CB1805	REF		
R91	RES,MF,1K +/-1%,1/8W	474445	91637	CMF551001F	1		
R92	RES,MF,100 +/-1%,1/8W	474437	91637	CMF551000F	REF		
R93	RES,MF,7.50K +/-1%,1/8W	223529	91637	CMF557501F	1		
R94	RES,MF,51.1K +/-1%,1/8W	289553	91637	CMF555112F	1		
R95	RES,COMP,1K +/-5%,1/4W	148023	01121	CB1025	REF		
R96	SELECTED IN TEST				REF		
R97	SELECTED IN TEST						
R98	RES,MATCHED SET	458299	89536	458299	2	1	1
R99	RES,MF,20.5K +/-1%,1/8W	261669	91637	CMF552052F	REF		
R100	RES,MF,499K +/-1%,1/8W	268813	91637	CMF554993F	REF		
R101	RES,VAR,CER,10K +/-10%,1/2W	309674	89536	309674	2	1	
R102	RES,MF,357K +/-1%,1/8W	235002	91637	CMF553573F	1		
R103	RES,MF,110K +/-1%,1/8W	234708	91637	CMF553573F	1		
R104	RES,MF,20.5K +/-1%,1/8W	261669	91637	CMF552052F	2		
R105	SELECTED IN TEST				REF		
R106	RES, MATCHED SET	458299	89536	458299	REF		
R107	RES,MF,82.5K +/-1%,1/8W	246223	91637	CMF558252F	2		
R108	RES,MF,82.5K +/-1%,1/8W	246223	91637	CMF558252F	REF		2
R109	RES,MF,2K +/-1%,1/8W	235226	91637	CMF552001F	1		
R110	SELECTED IN TEST				REF		
R111	RES,VAR,CER,5K +/-10%,1/2W	327569	89536	327569	REF		
R112	RES,MF,3.01K +/-1%,1/8W	322645	91637	CMF553011F	1		
R113	RES,MF,169K +/-1%,1/8W	289454	91637	CMF551693F	1		
R114	RES,COMP,510 +/-5%,1/4W	218032	01121	CB5115	REF		
R115	RES,MF,14.3K +/-1%,1/8W	291617	91637	CMF551432F	1		
R117	RES,MF,1K +/-1%,1/8W	168229	91637	CMF551001F	1		
R118	RES,COMP,150K +/-5%,1/4W	275685	01121	CB1545	1		
U1	RMS SENSOR KIT	489377	89536	489377	1	1	
U2	IC,OP AMP,J-FET	357830	89536	357830	1	1	
U3	IC,LINEAR,OP AMP	418566	18324	LM358/CR3999	2		
U4	IC,LINEAR,OP AMP	418566	18324	LM358/CR3999	REF		
U5	IC,LINEAR 5 XSTR ARRAY	248906	02735	CA3046	1	1	
VR1	DIODE,ZENER,5.6V	277236	07910	IN752A	2	1	
VR2	DIODE,ZENER,5.6V	277236	07910	IN752A	REF		
VR3	DIODE,ZENER	330829	07910	IN4571	1	1	
VR4	DIODE,ZENER 13V	110726	07910	IN964B	1	1	
XR18	SOCKET,IN-LINE,5-CNTCT(NOT SHOWN)	417899	52072	CA-05S-TSD	5		
XR35	SOCKET,IN-LINE,5-CNTCT(NOT SHOWN)	417899	52072	CA-05S-TSD	REF		
XR65	SOCKET,IN-LINE,5-CNTCT	417899	52072	CA-05S-TSD	REF		
XR79	SOCKET,IN-LINE,5-CNTCT(NOT SHOWN)	417899	52072	CA-05S-TSD	REF		

 THESE RESISTORS ARE PART OF THE RMS SENSOR KIT AND MAY BE OBTAINED WITH THE SENSOR BY ORDERING PART#489377 (SEE SECTION 4,"RMS SENSOR REPLACEMENT")

Option & Accessory Information

6-1. INTRODUCTION

6-2. This section of the manual contains information concerning the options and accessories available for use with the Model 8920A or 8921A. It consists of an introductory section, an accessories subsection and a series of option subsections. All options and accessories are listed by model or option number in the table of contents included in this section.

6-3. Hardware type accessories, i.e., rack mounting kits and cables, are documented in the accessories subsection.

While option numbers (-003, -004) are documented as individual subsections. Each subsection contains all of the information necessary to install, operate and maintain each option and accessory. This includes a list of replaceable parts and a schematic (if applicable).

6-4. The location of a particular subsection is facilitated by the use of unique page and paragraph numbering which corresponds to the option or accessory in question. For example, a 600-X series identifies the general accessories subsection and a 604-X series identifies the subsection for the -004 option (where X is the individual page or paragraph number).

TABLE OF CONTENTS

OPTION/ MODEL NO.	DESCRIPTION	PAGE
	ACCESSORIES	600-1
	OPTIONS	
-003	Counter Output Option	603-1
-004	Logarithmic Analog Output Option	604-1

-003 Option Counter Output

603-1. INTRODUCTION

603-2. The -003 Counter Output Option converts an rms input signal into an isolated 100 mV peak, square wave suitable for triggering a counter. There are several advantages as opposed to using separate inputs for the DVM and the counter. First, the 8920A or 8921A autoranged input has a much greater dynamic range than a counter. This means that input sensitivity is increased to 180 μ V while, on the other hand, inputs as large as 700V rms will not overload the counter. In practice, inputs should be 1.8 mV or greater due to possible false triggering effects of noise riding on lower level inputs. Secondly, because the counter output is isolated, frequency sources as high as 500V common mode voltage above earth ground can be measured (with the 8921A). Third, only one probe is needed to make a simultaneous voltage and frequency measurements. The counter option is available on both the 8920A and 8921A.

603-3. SPECIFICATIONS

603-4. Specifications for the Counter Output Option are given in Section I of this manual.

603-5. INSTALLATION

603-6. The Counter Output Option may be installed on either the 8920A or the 8921A. Install the Counter Output Option as follows, referring to Figure 603-1.

1. Remove 8920A 8921A top cover (see Access Information).
2. Plug Counter Output Option into J106-1, J106-3 of the A2 AC PCB Assembly and mechanically secure with the three screws provided; one on the AC Assembly shield and two on the rear panel.

3. Connect the 3-wire cable (P401) to J401 on the Main PCB Assembly-A1.

4. Verify operation using the calibration procedure.

5. Replace the shields.

603-7. OPERATION

603-8. Once installed, the Counter Output Option requires no operator attention other than ensuring that no voltage is ever applied to the option's rear panel BNC output (J402).

603-9. THEORY OF OPERATION

603-10. As shown in Figure 603-2, the Counter Output Option utilizes an isolation amplifier, two Schmitt triggers, pulse transformer and a DC-DC power supply to provide an isolated output suitable for triggering a counter. The isolation amp is used as a buffer between amplifier B's output and the first Schmitt trigger. The Schmitt trigger drives the pulse transformer with a square wave at the same frequency as the sine wave input. The pulse transformer provides isolation between the input common and output common allowing frequency sources with as high as 500V common mode voltage to be measured with the 8921A. The second Schmitt trigger is used to convert the pulse transformer output to the 100 mV square wave output at the same frequency as the sine wave input. The DC-DC power supply provides isolated +5.3V and -6.5V for the second Schmitt trigger.

603-11. MAINTENANCE

603-12. The following maintenance information covers three areas; performance testing, calibration and troubleshooting of the -003 Counter Output Option. However, before any of these procedures can be started,

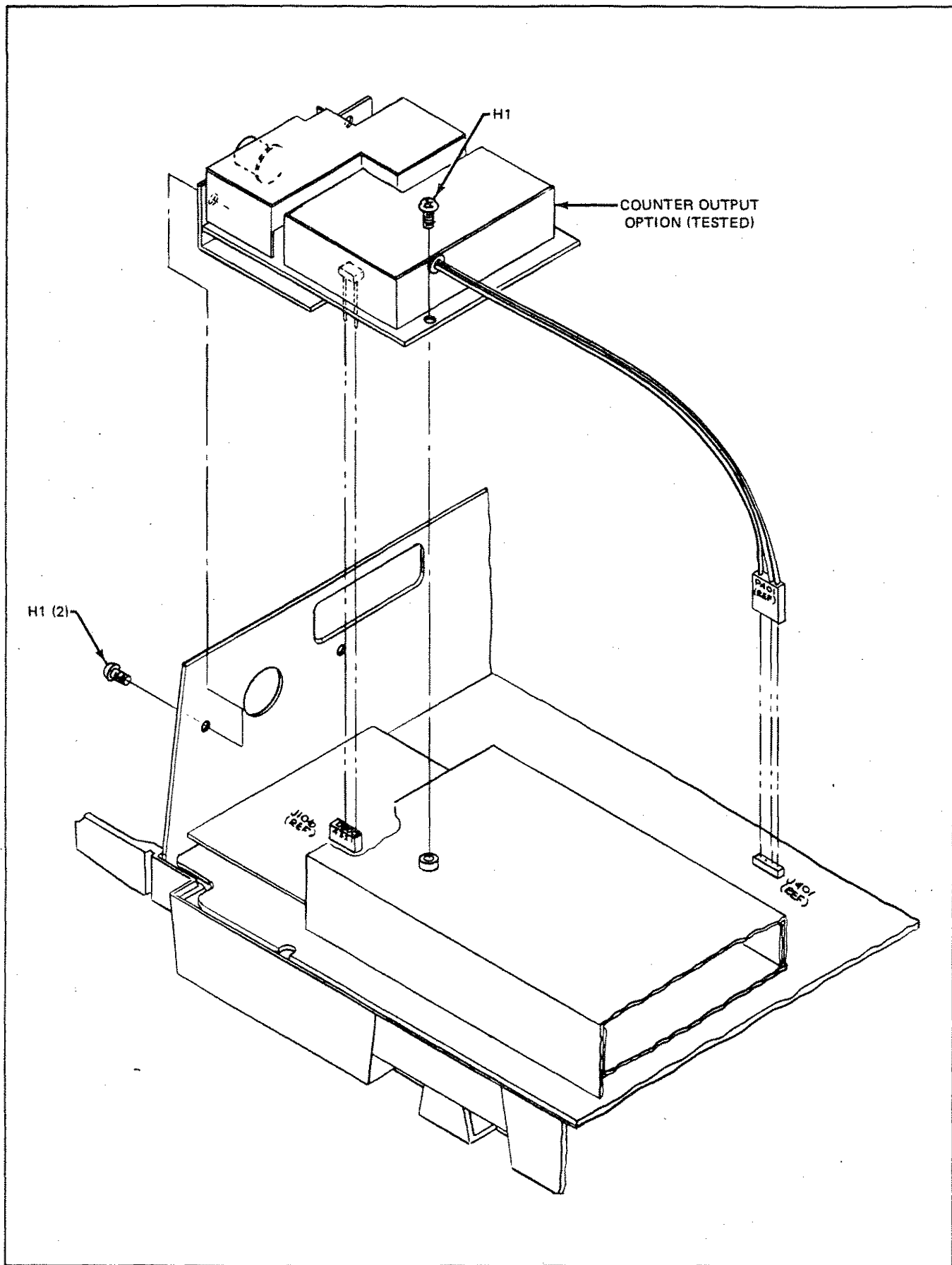

Figure 603-1. Counter Output Option Installation

603-2

8920A/8921A

Accessories

600-1. RACK MOUNTING KIT, SINGLE (Y2014)

600-2. The 8920A/8921A can be rack-mounted in a standard 19-inch equipment rack using Rack Mounting Kit (Y2014). The kit comes complete with installation instructions.

600-3. RACK MOUNTING KIT, DOUBLE (Y2015)

600-4. The 8920A/8921A can be rack mounted side by side in a standard 19-inch equipment rack using Rack

Mounting Kit (Y2015). The kit comes complete with instructions for installing any two C size PTI cases into a standard equipment rack.

600-5. PANEL ADAPTER KIT, DIN SIZE, (Y2020)

600-6. The 8920A/8921A can be rack mounted in a DIN size equipment rack using the Panel Adapter Kit (Y2020). The kit comes complete with instructions for installing the front panel adapter onto the 8920A or 8921A.

600-1/600-2

8920A/8921A



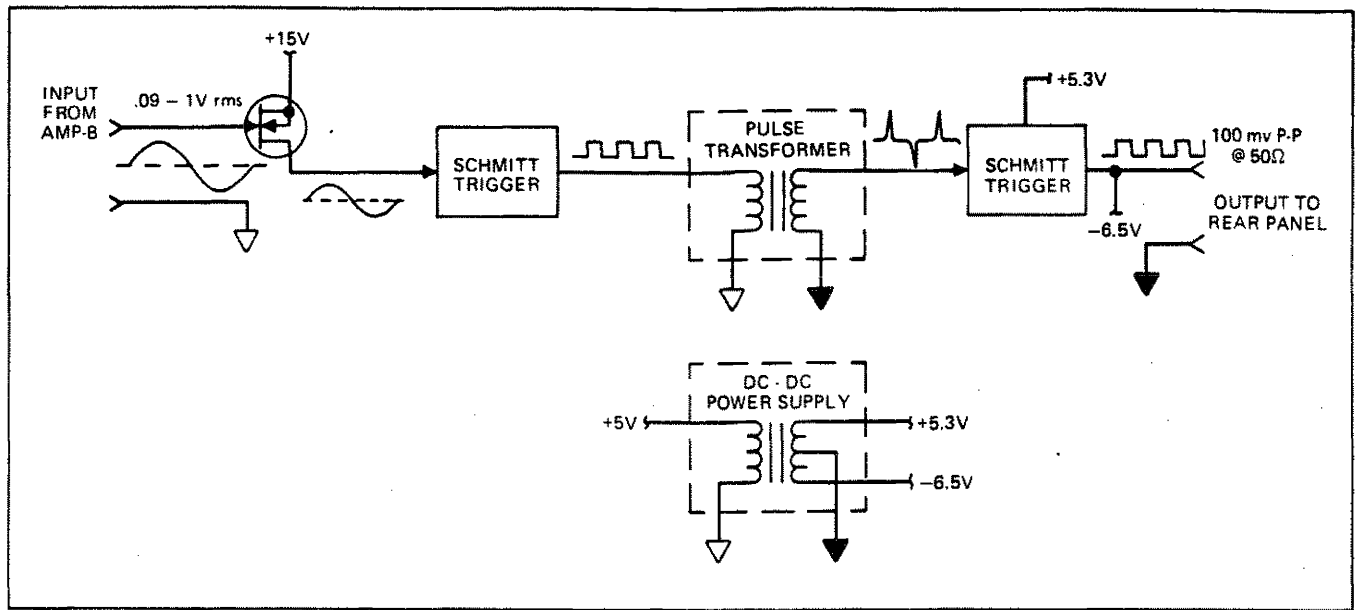

Figure 603-2. Counter Output Option Simplified Schematic

the calibration of the mainframe instrument (8920A or 8921A) must be successfully completed. The table of recommended test equipment in Section 4 lists all of the equipment necessary to check, calibrate and troubleshoot the mainframe instrument. Any additional equipment required to check and calibrate the -003 Option is listed in Table 603-1. If you are unable to obtain the recommended test equipment insure that the substitute has equal or better performance specifications.

NOTE

For the following procedures the 8920A and 8921A will be referred to as the UUT (Unit Under Test).

Table 603-1. Recommended Test Equipment

QTY	EQUIPMENT NOMENCLATURE	REQUIREMENT	RECOMMENDED EQUIPMENT
1	Universal Counter-Timer	100 Hz-20 MHz	Fluke 1953A
2	Oscilloscope	DC to 200 MHz 1.8 ns	Tektronix 475

603-13. Performance Test

603-14. The following procedure will verify that the Counter Output Option is operating within the specification limits stated in Section 1.

1. Connect the AC Calibrator, UUT, oscilloscope and termination as shown in Figure 603-3.

2. Set the AC Calibrator to its 10V range, set the UUT to AC FUNCTION, VOLTS DISPLAY MODE and 2V range, HOLD and set the oscilloscope's time base to 0.2 sec/div and Vert on 50 mV/div.

3. Referring to Table 603-2, change input to UUT as indicated and note that display values are within indicated tolerances.

4. Disassemble the setup as shown in Figure 603-3 and connect the SG503, UUT, and Universal Counter-Timer and terminations, as shown in Figure 603-4.

5. Set the SG503 to its 10-25 MHz range, set the Universal Counter-Timer for frequency ratio measurement with 10 sec gate interval, and set the UUT to AC FUNCTION, VOLTS DISPLAY MODE and 200 mV RANGE HOLD.

6. Referring to Table 603-3, change input to UUT as indicated and note that display values are within indicated tolerances.

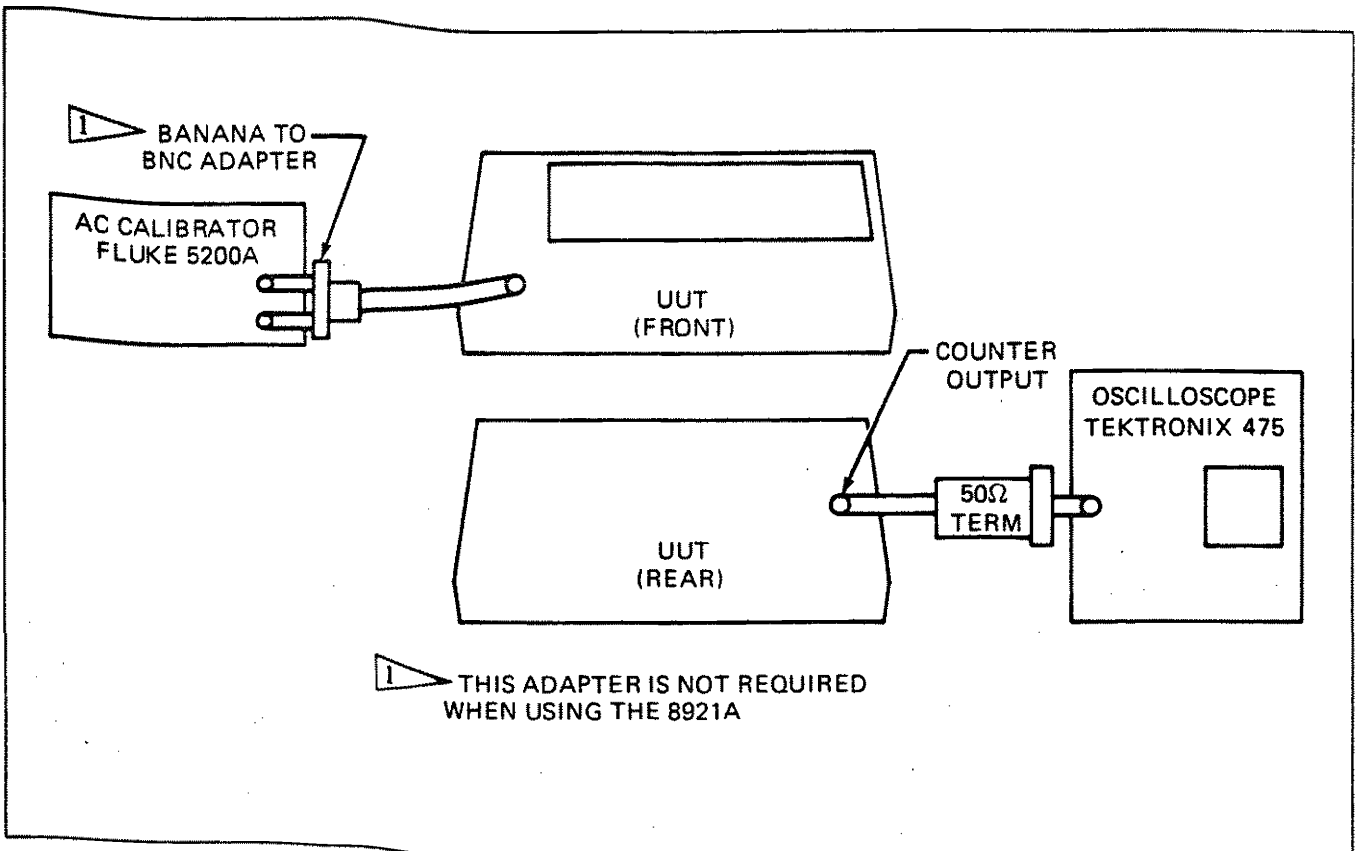

Figure 603-3. Counter Output Performance Set-Up

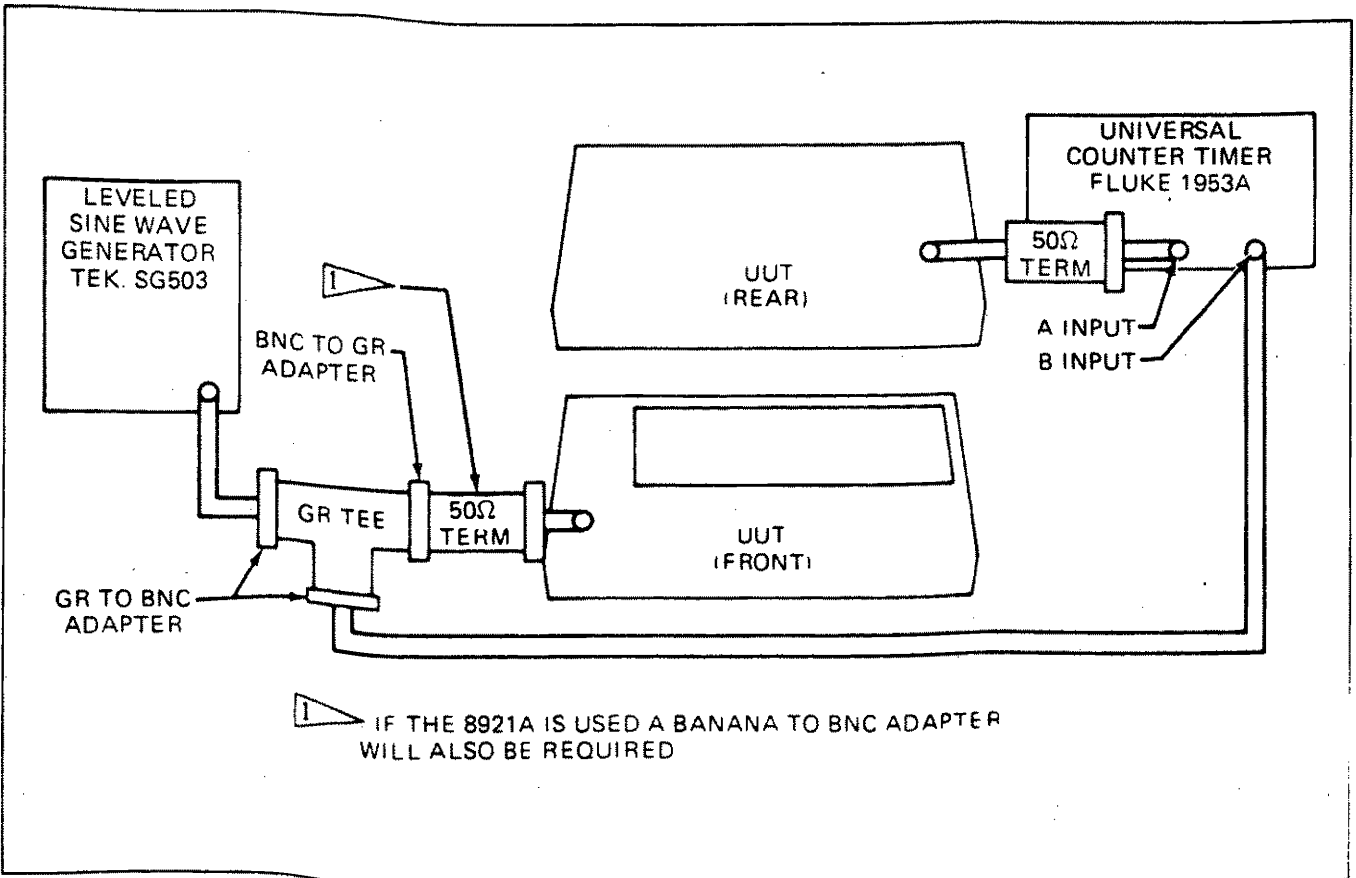

Figure 603-4. Counter Output Performance Test Set-Up

Table 603-2. Counter Output Amplitude

AC CAL-IBRATOR OUTPUT	UUT DISPLAY	OSCILLOSCOPE DISPLAY $\pm 20\%$	COMMENTS
1.9V, 1 kHz	1.900	Observe 100 mV squarewave.	Adjust calibrator output to obtain UUT display.
0.18V 1 kHz	.180	Observe 100 mV squarewave	Adjust calibrator output to obtain UUT display.

Table 603-3. Counter Output Frequency Response

SG503 OUTPUT	UUT DISPLAY	COUNTER-TIMER DISPLAY ± 1 DIGIT	COMMENTS
18 mV, 20 MHz	18.0	1.00000	Adjust the SG503 output to obtain UUT display.
180 mV, 20 MHz	180.0	1.00000	Adjust the SG503 output to obtain UUT display.

603-15. Calibration

603-16. The Counter Output Option should be calibrated when it is first installed or if the limits, as stated in the performance test cannot be met. Use the following procedure to calibrate the Counter Output Option. If it is not possible to obtain the limits as stated in the following

procedure then the option will require troubleshooting. If, however, the limits are met then we recommend that the performance test be completed as a check.

1. Remove the UUT's top cover and measure the inverter power supply voltages:

MEASURE BETWEEN	DVM DISPLAY
C413 and Ground	5.0V, $\pm 0.3V$
C414 and Ground	-6.2V, $\pm 0.3V$

2. Connect the AC Calibrator, UUT, oscilloscope and terminations as shown in Figure 603-3.

3. Set the AC Calibrator to its 1V range at 10 kHz, set the oscilloscope time base to 20 usec div. and Vert to 50 mV/div. and set the UUT to AC FUNCTION, VOLTS DISPLAY MODE and 2V range HOLD.

4. Apply 180 mV/10 kHz from the AC Calibrator to the input of the UUT. Using the oscilloscope check the UUT's counter output and adjust R404 until a symmetrical square wave is obtained. The amplitude of the square wave should be 100 mV peak, $\pm 20\%$ and must not change as the input to the UUT is increased up to 18V.

5. Disassemble the set up as shown in Figure 603-3 and connect the SG503, UUT, Universal Counter-Timer and terminations as shown in Figure 603-5.

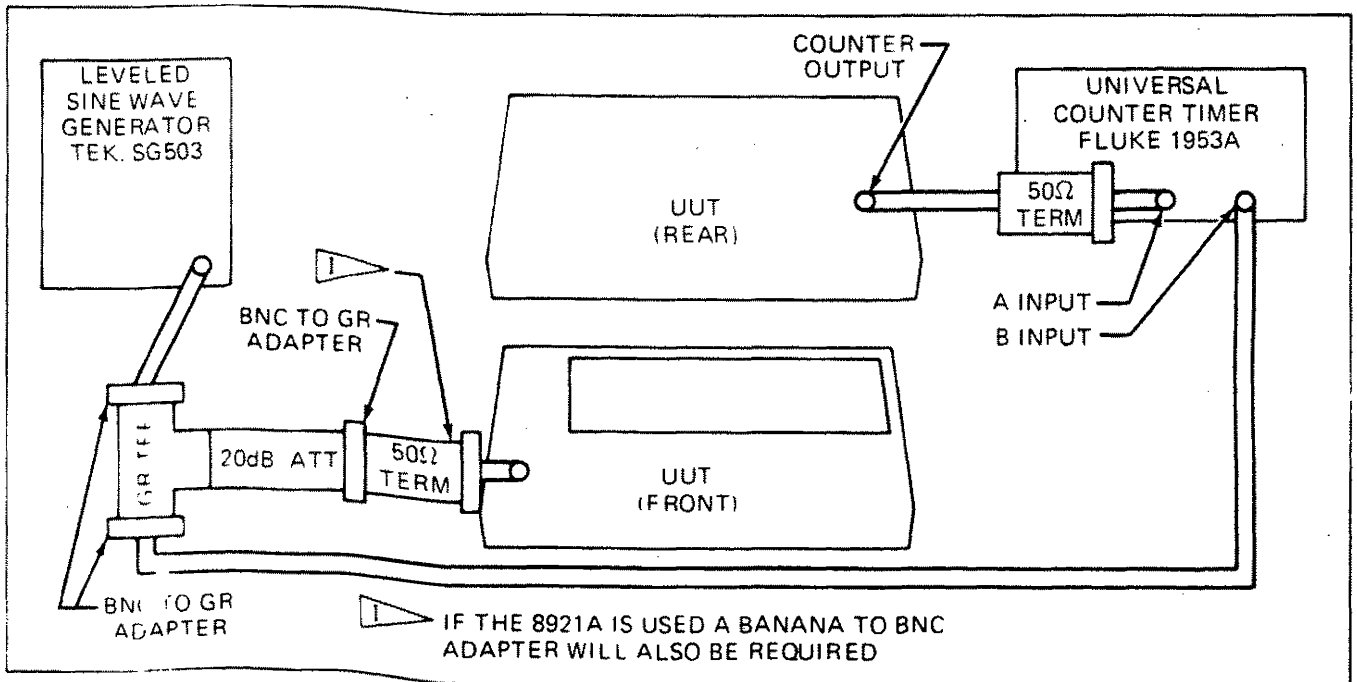

Figure 603-5. Calibration Set-Up

6. Set the SG503 to its 10-25 MHz range, set the Counter-Timer for frequency ratio measurement with a 10 sec gate interval and set the UUT to AC FUNCTION, VOLTS DISPLAY MODE and 200 mV range HOLD.

7. Select a 20 MHz output on the SG503 and adjust its amplitude with the vernier control until the UUT reads 18.0 mV. At this point, the Counter-Timer should display a stable reading of 1.00000 ± 1 digit.

8. Reduce the output amplitude of the SG503 until the Counter-Timer display limit of step 7 cannot be met.

9. Adjust R404 until the Counter-Timer display limit of step 7 is met.

10. Repeat steps 8 and 9 until the Counter-Timer display limit can be met at the lowest possible input level.

603-17. Troubleshooting

603-18. Table 603-4 should be completed ONLY if the performance test and calibration procedure indicate the the -003 Counter Output Option IS NOT operating correctly. This table includes voltage levels and waveforms of a properly functioning -003 Option. If you are unable to obtain any value ($\pm 15\%$) then you should replace the defective component and repeat the entire troubleshooting procedure. However, if all values are obtained then the performance test and calibration procedure must be repeated.

603-19. LIST OF REPLACEABLE PARTS

603-20. A list of replaceable parts for the Counter Output Option is given in Table 603-5 and shown in Figure 603-6. Refer to Section 5 of this manual for ordering information.

Table 603-4. Counter Output Option Troubleshooting

1. Using the 8020A or any compatible 3 1/2 digit meter, measure the following supply voltages.

SUPPLY VOLTAGE	MEASURE BETWEEN HIGH TERMINAL AND LOW TERMINAL	DVM DISPLAY (8020A)
+15	U401-1 and Input Common*	+15.00, $\pm 0.1V$
-15	U401-6 and Input Common*	-15.00 $\pm 0.2V$
+5	T402-2 and Input Common*	+5.00 $\pm 0.25V$
+5.3	U401-1 and Chassis Ground*	+5.3 $\pm 0.3V$
-6.5	U401-6 and Chassis Ground*	-6.5 $\pm 0.3V$

2. Using an oscilloscope (with x10 probe) Tek 475 or equivalent, check the following points for the indicated waveforms.

MEASURE BETWEEN HIGH TERMINAL - LOW TERMINAL

T402-1 and Input Common*
T402-3 and Input Common*

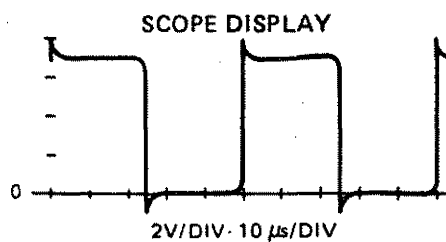

T402-6 and Input Common*
T402-8 and Input Common*

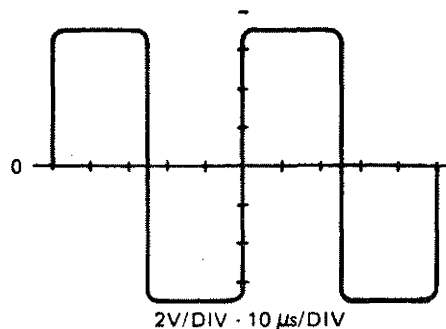

Table 603-4. Counter Output Option Troubleshooting (cont)

2a. Using Fluke 5200A or equivalent, apply 1V/10 kHz signal to input of UUT.

MEASURE BETWEEN HIGH
TERMINAL - LOW TERMINAL

SCOPE DISPLAY

Gate of Q401A and Input Common*

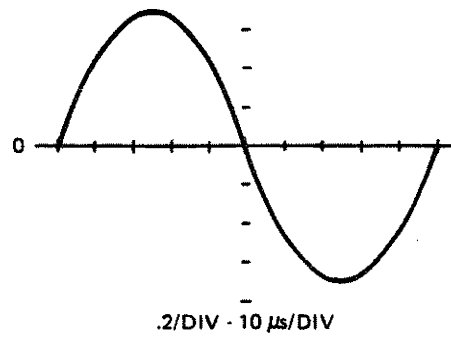

Drain of Q401B and Input Common*
U401-3 and Input Common*

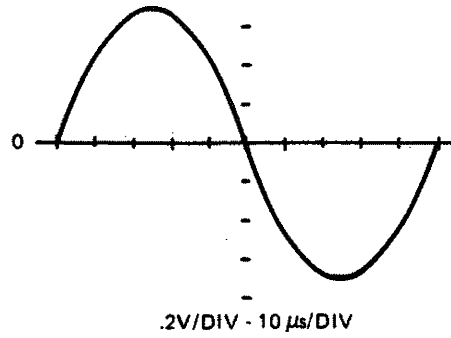

U401-4 and Input Common*

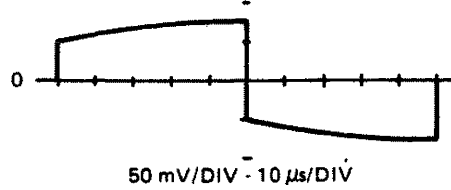

U401-9 and Input Common*

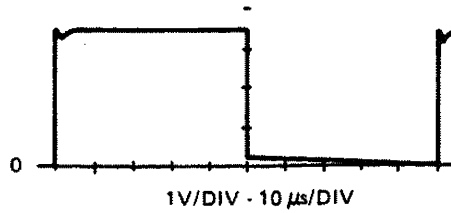

T401 input and Input Common*

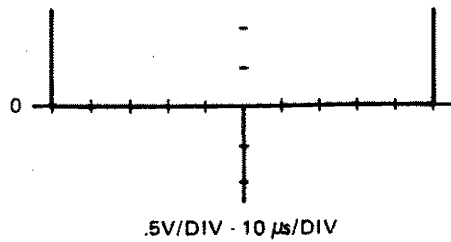
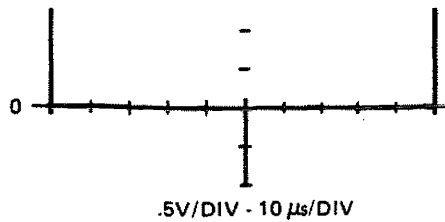

Table 603-4. Counter Output Option Troubleshooting (cont)

MEASURE BETWEEN HIGH
TERMINAL—LOW TERMINAL

SCOPE DISPLAY

T401 output and Chassis Ground*



U402-4 and Chassis Ground*

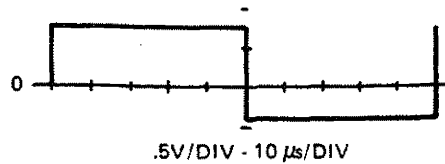

U402-9 and Chassis Ground*

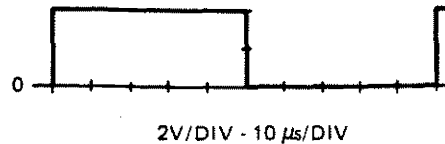

J402 and Chassis Ground*

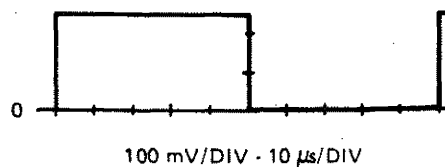

*Input Common = ∇ see schematic at end of this manual, Section 8.

*Chassis Ground = \blacktriangledown see schematic at end of this manual, Section 8.

5. Press the 8920A dB/VOLTS switch to the dB position then the REL/dBm switch to the REL position. The 8920A display will be ± 0.00 dB.
6. Select the 20 volt range on the DVM.
7. Use the decade switch on the ac source to increase the 8920A input at the levels indicated in Table 604-1. Note the DVM and 8920A displays to be within the tolerances given

Table 603-5. Counter Output Option PCB Assembly

ITEM NO.	DESCRIPTION	FLUKE STOCK NO.	MFG SPLY CODE	MFG PART NO. OR TYPE	TOT QTY	REC QTY	USE CDE
-003	COUNTER OUTPUT OPTION	ORDER	-003	OPTION	1		
C401	CAP,CER, 0.22UF	309849	71590	CW30C2241K	5		
C402	CAP,CER,430PF +/-5%,500V	177980	72136	DM15F431J	1		
C403	CAP,CER, 0.22UF	309849	71590	CW30C2241K	REF		
C404	CAP,CER, 0.22UF	309849	71590	CW30C2241K	REF		
C406	CAP,TA,47UF +/-20%,20V	348516	56289	196D476X0020TE4	1		
C407	CAP,CER,0.005UF +/-20%,100V	175232	56289	C023B101E502M	1		
C408	CAP,CER, 0.22UF	309849	71590	CW30C2241K	REF		
C409	CAP,CER,0.01UF +/-20%,100V	149153	56289	C023B101F103M	1		
C410	CAP,CER, 0.22UF	309849	71590	CW30C2241K	REF		
C411	CAP,TA,220UF +/-20%,10V	474288	56289	196D227X0010TE4	2		
C412	CAP,TA,220UF +/-20%,10V	474288	56289	196D227X0010TE4	REF		
C413	CAP,CER,4.7UF +/-20%,50V	363721	56289	196D475X0050PE4	2		
C414	CAP,CER,4.7UF +/-20%,50V	363721	56289	196D475X0050PE4	REF		
C415	CAP,CER,300PF,3KV	485250	56289	C028B02E301M	1		
CR401	DIODE,SI,HI-SPEED,SWITCH	203323	07940	1N4448	7	2	
CR402	DIODE,SI,HI-SPEED,SWITCH	203323	07940	1N4448	REF		
CR403	DIODE,SI,HI-SPEED,SWITCH	203323	07940	1N4448	REF		
CR404	DIODE,SI,HI-SPEED,SWITCH	203323	07940	1N4448	REF		
CR405	DIODE,SI,HI-SPEED,SWITCH	203323	07940	1N4448	REF		
CR406	DIODE,SI,HI-SPEED,SWITCH	203323	07940	1N4448	REF		
CR407	DIODE,SI,HI-SPEED,SWITCH	203323	07940	1N4448	REF		
H1	SCREW, 4-40 X 1/4 SST	256156	73734	23022	2		
J402	CONN,BNC,FEMALE	152033	95712	30355-1	1		
L401	CHOKE,6 TURN	320911	89536	320911	3		
L402	CHOKE,6 TURN	320911	89536	320911	REF		
L403	CHOKE,6 TURN	320911	89536	320911	REF		
L404	INDUCTOR SHEILDED,0.27UH	313031	24859	MR-0.27	1		
MP1	SHIELD	475491	89536	475491	1		
MP2	SHIELD	475483	89536	475483	1		
MP3	SHIELD	475376	89536	475376	1		
MP7	COVER	475509	89536	475509	1		
MP8	COVER	475400	89536	475400	1		
MP9	BUS WIRE #20	115469	89536	115469	AR		
MP10	BRACKET	456723	89536	456723	1		
MP11	SHIELD	475384	89536	475384	1		
P106	POST,CONTACT	474809	22526	65505-136	3		
P401	CABLE,-003 OPTION	486670	89536	486670	1		
Q401	XSTR,DUAL FET	454637	89536	454637	1	1	
Q402	XTSR,SI,NPN	272237	89536	272237	2	1	
Q403	XTSR,SI,NPN	272237	89536	272237	REF		
R402	RES,MF,1K +/-1%,1/8W	168229	91637	CMF551001F	2		
R403	RES,MF,1K +/-1%,1/8W	168229	91637	CMF551001F	REF		
R404	RES,VAR,100K +/-10%,1/2W	369520	89536	369520	1	1	
R405	RES,COMP,20K +/-5%,1/4W	221624	01121	CB2035	1		
R406	RES,COMP,9.1K +/-5%,1/4W	193318	01121	CB9125	1		
R407	RES,COMP,51,+/-5%,1/4W	221879	01121	CB5105	2		
R408	RES,COMP,1.2K +/-5%,1/4W	190371	01121	CB1225	1		
R409	RES,COMP,15K +/-5%,1/4W	148114	01121	CB1535	1		
R410	RES,COMP,220 +/-5%,1/4W	147959	01121	CB2215	1		

Table 603-5. Counter Output Option PCB Assembly (cont)

ITEM NO.	DESCRIPTION	FLUKE STOCK NO.	MFG SPLY CODE	MFG PART NO. OR TYPE	TOT QTY	REC QTY	USE CDE
R411	RES,COMP,47 +/-5%,1/4W	147892	01121	CB4705	1		
R412	RES,COMP,680 +/-5%,1/4W	148007	01121	CB6815	2		
R413	RES,COMP,470 +/-5%,1/4W	147983	01121	CB4715	1		
R414	RES,COMP,5.1K +/-5%,1/4W	193342	01121	CB5125	1		
R415	RES,COMP,1K +/-5%,1/4W	148023	01121	CB1025	1		
R416	RES,COMP,680 +/-5%,1/4W	148007	01121	CB6815	REF		
R417	RES,COMP,51 +/-5%,1/4W	221879	01121	CB5105	REF		
T401	TRANSFORMER	461863	89536	461864	1		
T402	TRANSFORMER	472798	89536	472498	1		
U401	IC,LIN,HI-SPEED ANALOG VOL COMPARTOR	386920	12040	LM361N	2	1	
U402	IC,LIN,HI-SPEED ANALOG VOL COMPARTOR	386920	12040	LM361N	REF		

 Refer to Figure 603-1

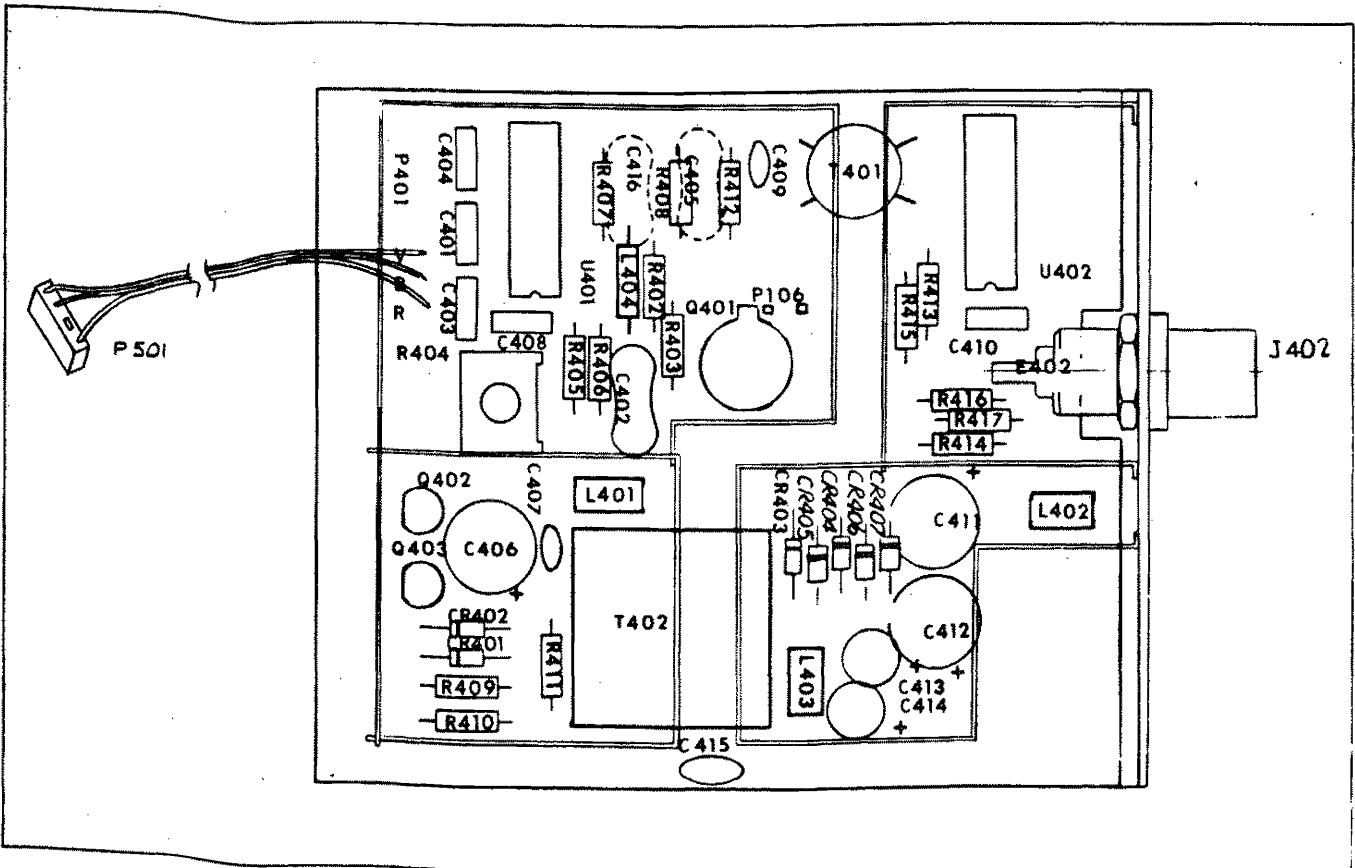

Figure 603-6. Counter Output Option PCB Assembly

-004 Option Logarithmic Analog Output

604-1. INTRODUCTION

604-2. The Logarithmic Analog Output Option provides a non-isolated output voltage which varies continuously as the logarithm of the rms input. Scaling is: 0V dc output corresponds to 0 dB which is 200 μ V rms input to the 8920A while 13.1V dc output = 131 dB = 700V rms input. A continuous frequency response of circuits with a wide dynamic output is easily plotted on an XY recorder using this option. The option's output is non-isolated, and is available only on the 8920A.

604-3. SPECIFICATIONS

604-4. Specifications for the Logarithmic Analog Output Option are given in Section 1 of this manual.

604-5. INSTALLATION

604-6. The Logarithmic Analog Output Option may be installed on the 8920A only. Install the option as follows, referring to Figure 604-1.

1. Remove the top cover (see Access Procedures).
2. Remove the plate located at the top of the 8920's rear panel.
3. Install the Banana Jack plate with the red banana jack to the right (when viewing the 8920A from the rear).
4. Secure the Logarithmic Analog Output Assembly to the top of the transformer bracket (see Figure 604-1) using the two screws provided.
5. Plug P501 into J501 (located on the Main PCB Assembly).
6. Solder the Logarithmic Analog Output Assembly's red output lead to the red banana jack and the black lead to the black banana jack.

604-5. OPERATION

604-6. Once installed, the Logarithmic Analog Output Option requires no operator attention other than ensuring that no voltage is ever applied to the option's output banana jacks.

604-7. THEORY OF OPERATION

604-8. The Logarithmic Analog Output Option, illustrated in Figure 604-2, utilizes the logarithmic characteristics of a P-N junction to develop an output proportional to the logarithm of the dc input from the thermal sensor.

604-9. The dc output voltage of the thermal sensor develops a collector current in one-half of a dual transistor. The resulting emitter base voltage is compared to the reference V_{be} of the second half and scaled up accordingly. This voltage in turn develops a current which is summed with range information to produce the logarithmic output.

604-10. The output of the sensor covers one decade (.1 to 1V) in any one range. Scaling is such that one decade corresponds to 2V or 20 dB (.1V = 1 dB) at the output. "0" dB corresponds to 200 μ V and each range increase produces an additional 2V at the output. Transients during range changes are eliminated by a sample and hold circuit.

604-11. MAINTENANCE

604-12. The following maintenance information covers three areas; performance testing, calibration and troubleshooting of the -004 Logarithmic Analog Output Option. However, before any of these procedures can be started the calibration of the mainframe instrument (8920A) must be successfully completed. The table of recommended test equipment in Section 4 lists all of the

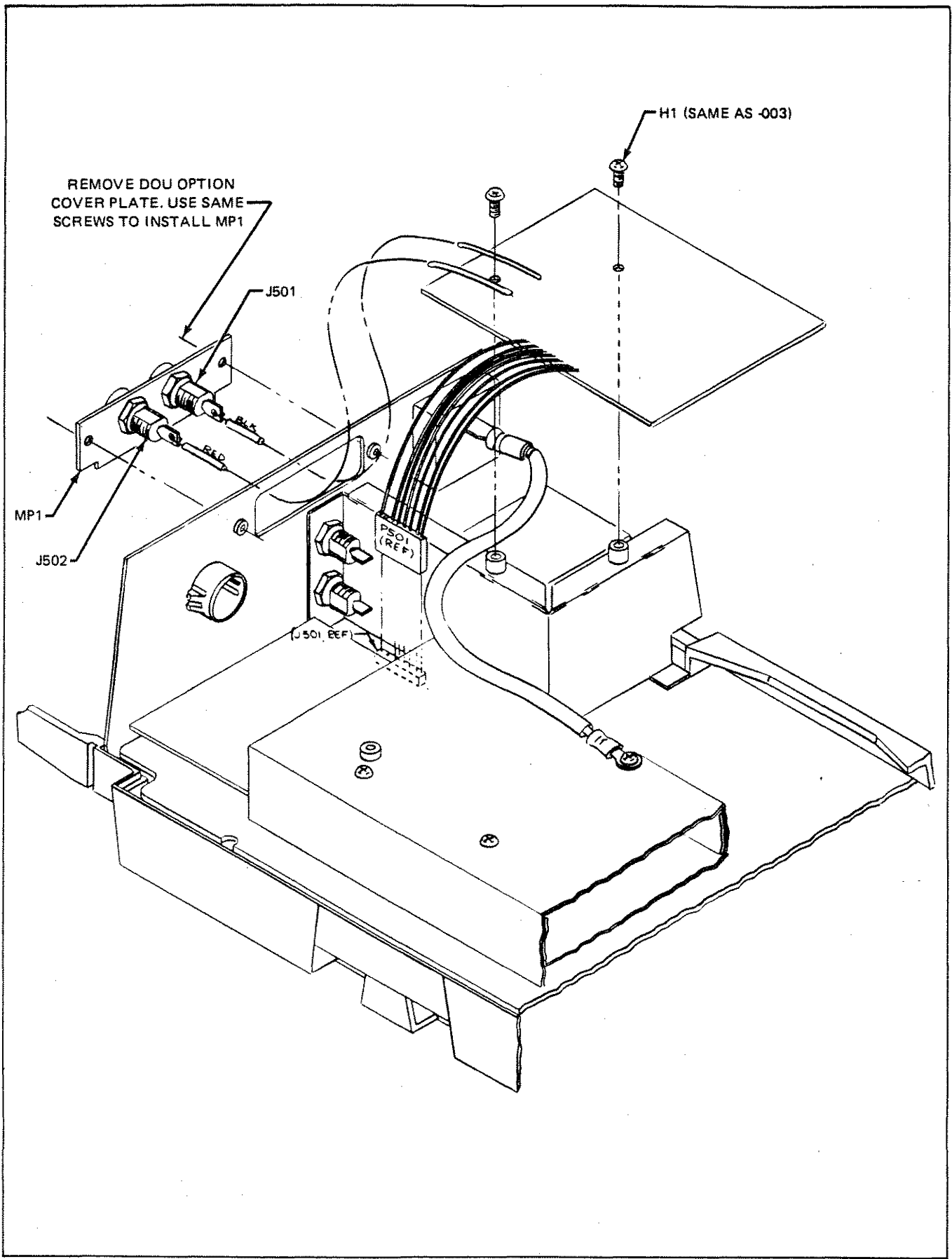



Figure 604-1. Logarithmic Analog Output Option Installation

Table 604-2. Logarithmic Analog Output Option PCB Assembly

ITEM NO.	DESCRIPTION	FLUKE STOCK NO.	MFG SPLY CODE	MFG PART NO. OR TYPE	TOT QTY	REC QTY	USE CDE
-004	LOGARITHMIC ANALOG OUTPUT OPT., FIG 606-4	ORDER	-004	OPTION	1		
C501	CAP, CER, 1000PF +/-10%, 500V	357806	56289	C016B102G102K	1		
C502	CAP, CER, 100PF +/-10%, 1000V	105593	71590	DD-101	1		
C503	CAP, MYLAR, 2.0UF +/-20%, 100V	334185	14752	230B1B105	1		
C504	CAP, TA, 22UF +/-20%, 15V	423012	56289	196D226X00154A1	1		
C505	CAP, ELECT, TA, 2.2UF +/-10%, 20V	160226	56289	150D225X9020A	2	1	
C506	CAP, ELECT, TA, 22UF +/-10%, 20V	160226	56289	150D225X9020A	REF		
CR501	DIODE, HI-SPEED, SWITCH	203323	07910	1N4448	3		
J501	BANANA JACK, BLACK	162073	74970	108-0903-001	1		
J502	BANANA JACK, RED	162065	74970	108-0902-001	1		
MP1	COVER PLATE, LOG ANALOG OPTION	456772	89536	456772	1		
P501	CABLE, LOGARITHMIC ANALOG OUTPUT	486688	89536	486688	1		
Q501	XSTR, DUAL, SI, NPN	295717	24355	AD811-00/17	1	1	
Q502	XSTR, FET, JNCT, N-CHANNEL	376475	89536	376475	1	1	
R501	RES, VAR, 100K +/-10%, 1/2W	369520	89536	369520	1	1	
R505	RES, MF, 10K +/-1%, 1/8W	168260	91637	CMF551002F	1		
R506	RES, COMP, 15M +/-5%, 1/4W	381491	01121	CB1565	1		
R507	RES, COMP, 10K +/-5%, 1/4W	148106	01121	CB1035	1		
R508	RES, MF, 37.5K +/-0.1%, 1/8W	442947	91637	CNF553752B	1		
R509	RES, MF, 75K +/-0.1%, 1/8W	370916	91637	CMF557502B	1		
R510	RES, MF, 150K +/-0.25%, 1/8W	442707	91637	CMF551503C	2		
R511	RES, MF, 100K +/-0.1%, 1/8W	370775	91637	CMF551003B	1		
R512	RES, VAR, 20K +/-10%, 1/2W	335760	89536	335760	1	1	
R513	RES, MF, 150K +/-0.25%, 1/8W	442707	91637	CMF551503C	REF		
R514	RES, COMP, 47K +/-5%, 1/4W	148163	01121	CB4735	1		
R515	RES, MF, 158K +/-1%, 1/8W	237214	91637	CMF551583F	1		
R516	RES, MF, 994 +/-2%, 1/2W	477018	89536	477018	1	1	
R518	RES, MF, 20K +/-0.1%, 1/8W	446443	91637	CMF552002B	1		
R519	RES, MF, 1.5M +/-1%, 1/2W	284976	91637	CMF651504F	1		
R520	RES, COMP, 1K +/-5%, 1/4W	148023	01121	CB1025	1		
R524	RES, MF, 100K +/-5%, 1/8W	248807	91637	CMF551003F	1		
R525	RES, MF, 143K +/-1%, 1/8W	291336	91637	CMF551433F	1		
TP501	CONNECTOR POST	379438	0779	1-87022-0	4		
TP502	CONNECTOR POST	379438	0779	1-87022-0	REF		
TP503	CONNECTOR POST	379438	0779	1-87022-0	REF		
TP504	CONNECTOR POST	379438	0779	1-87022-0	REF		
U501	IC, C-MOS, HEX BUFFER/INVERTER	381848	02735	CD4047AE	1	1	
U502	IC, LINEAR, OP AMP	402669	02735	CA324E	1	1	
W502	WIRE ASSEMBLY	488163	89536	488163	1		

 Refer to Figure 604-1

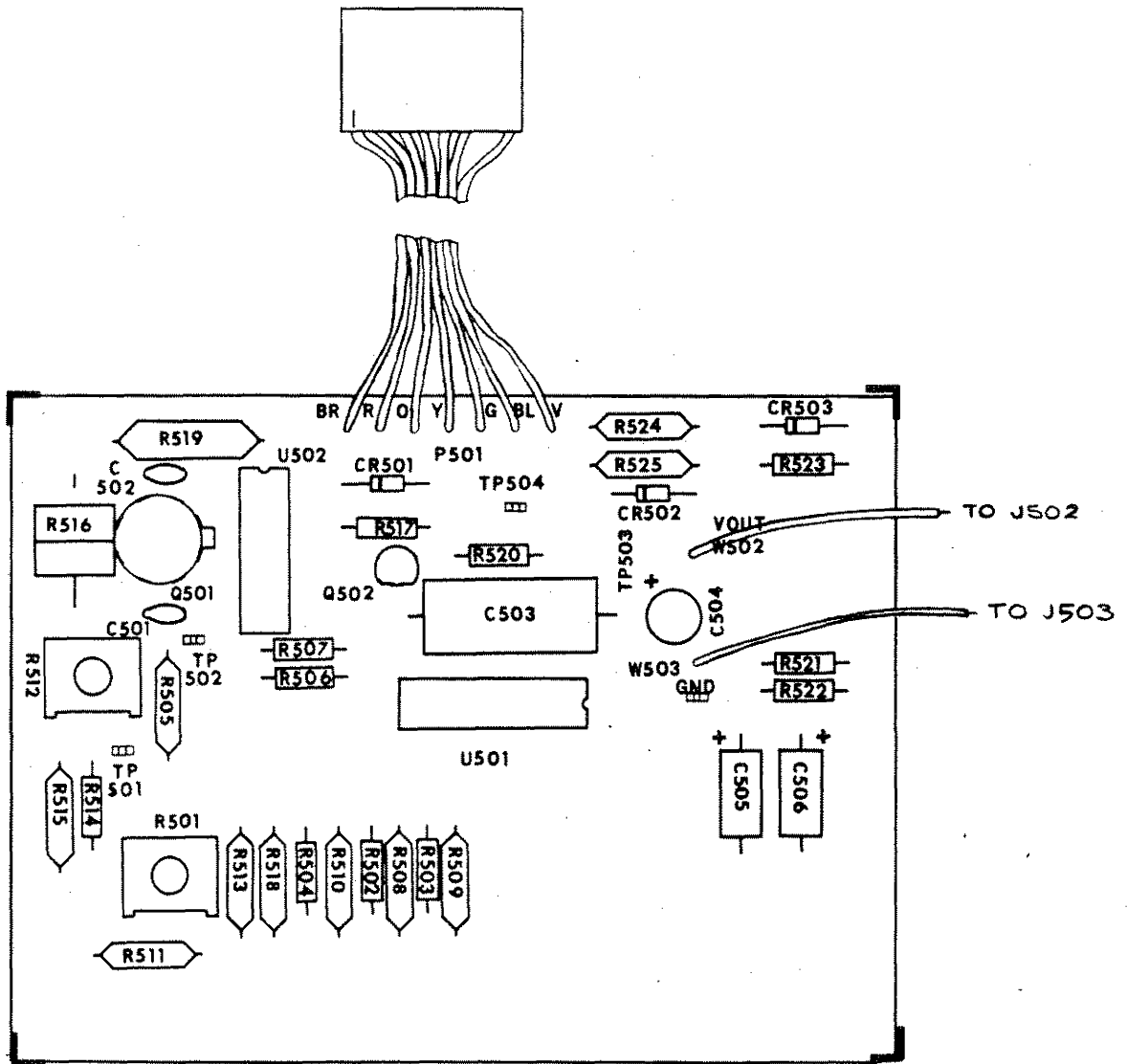

Figure 604-4. Logarithmic Analog Output Option PCB Assembly

604-6

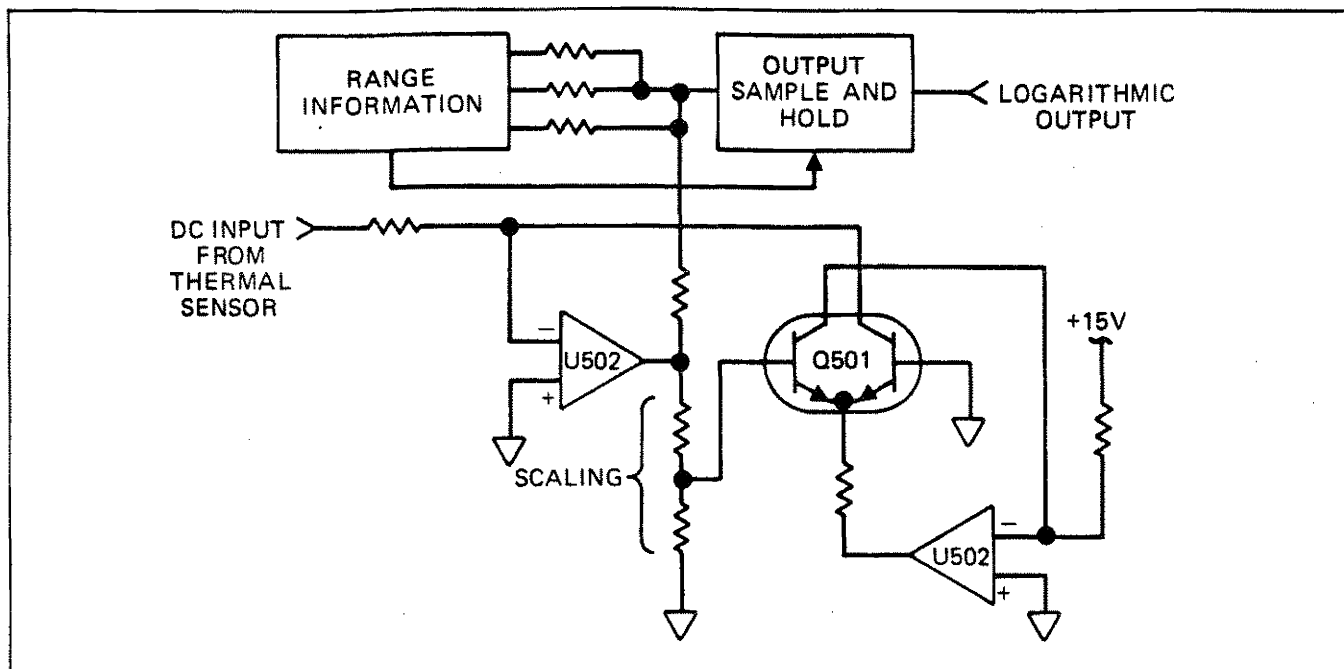

Figure 604-2. Logarithmic Analog Output Option Simplified Schematic

equipment necessary to calibrate the mainframe instrument. No additional equipment is required to check, calibrate or troubleshoot the -004 Option.

604-13. Performance Test

604-14. The following procedure will verify that the Logarithmic Analog Output Option is operating within the specification limits stated in Section I.

1. Select the AC function, LO RANGE ENABLE and AUTO range on the 8920A.
2. Apply 1.0 mV, 500 Hz to the 8920A INPUT connector.
3. Select the DC Volts function and 2 Volt range on the DVM; connect it to the LOGARITHMIC ANALOG OUTPUT jacks on the rear panel of the 8920A.
4. Adjust the vernier control on the AC source of a voltage reading on the DVM of $1.400 \pm .002$ Vdc.
5. Press the 8920A dB VOLTS switch to the dB position then the REL dBm switch to the REL position. The 8920A display will be ± 0.00 dB.
6. Select the 20 volt range on the DVM.
7. Use the decade switch on the ac source to increase the 8920A input to the levels indicated in Table 604-1. Note the DVM and 8920A displays to be within the tolerances given.

Table 604-1. Performance Test

8920A INPUT	8920A DISPLAY	DVM DISPLAY*
10 mV, 500 Hz	20.00 ± 0.25 dB	3.4 ± 0.24 V
100 mV, 500 Hz	40.00 ± 0.25 dB	5.4 ± 0.24 V
1V, 500 Hz	60.00 ± 0.25 dB	7.4 ± 0.24 V
10V, 500 Hz	80.00 ± 0.25 dB	9.4 ± 0.24 V
100V, 500 Hz	100.00 ± 0.25 dB	11.4 ± 0.24 V

* The tolerance limit represents total system inaccuracies.

604-15. Calibration

604-16. The Logarithmic Analog Option should be calibrated when it is first installed or if the limits as stated in the performance test cannot be met. Use the following procedure to calibrate the Logarithmic Analog Option. If it is not possible to obtain the limits as stated in the following procedure then the option will require troubleshooting. If, however, the limits are met then we recommend that the performance test be completed as a check.

1. Remove the 8920A's top cover, and set up the test equipment as shown in Figure 604-3.
2. Set the 8920A to AC, AUTO and select the LO RANGE ENABLE. Now apply 1.0 mV ac, 500 Hz. Observe the option's output to be approximately 1.4 ± 0.2 V dc. (TP504 is Ground, TP503 is the option's output.)

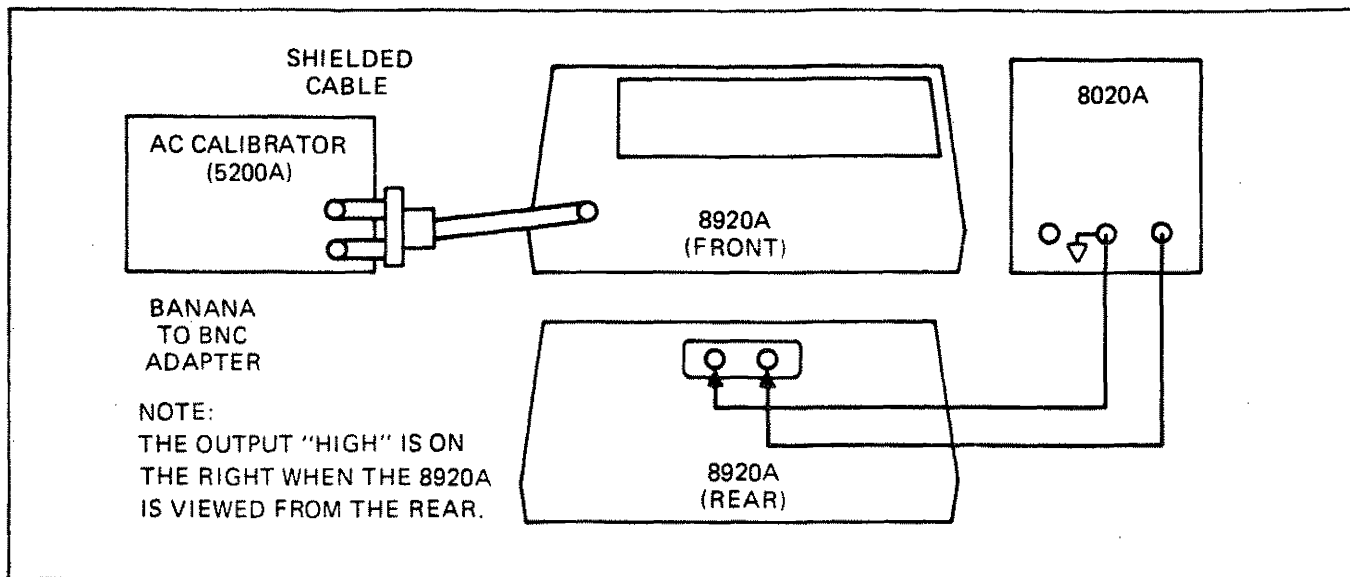

Figure 604-3. Logarithmic Analog Output Option Test Set-Up

3. Apply 20.0 mV, 500 Hz to the 8920A and select its HOLD RANGE. Monitor the voltage at TP502 and adjust R501 for a 0 ± 0.0005 Vdc on the DMM.
4. Monitor TP501 and note the magnitude and polarity of the offset from 0V to the nearest 0.01V.
5. While still monitoring TP501 adjust R512 for a reading of $-10V + \text{OFFSET}$ of step 3 $\pm 0.01V$.

Example:

Initial Offset	Final Reading
-03V	$-10 - 03 = -10.03 \pm 0.01V$
+14V	$-10 + 14 = -9.86 \pm 0.01V$

6. Monitor TP503 and note the offset from +6.00V to the nearest 0.01V.
7. Decrease the input to 100 mV, 500 Hz and observe that the DMM reads $+5.4V \pm 0.01V$ plus the offset noted in step 5.

8. Decrease the input to 20 mV, 500 Hz and observe that the DMM reads $+4.00V \pm 0.01V$ plus the offset noted in step 5.

604-17. Troubleshooting

604-18. To troubleshoot the -004 Option read the theory of operation for this option and then check the actual voltage levels against those indicated on the -004 schematic, located in Section 8. If there are any discrepancies, simply replace the defective component and repeat the performance test and calibration procedure.

604-19. LIST OF REPLACEABLE PARTS

604-20. A list of replaceable parts for the Logarithmic Analog Output Option is given in Table 604-2 and shown in Figure 604-4. Refer to Section 5 of this manual for ordering information.

Section 7

General Information

7-1. This section of the manual contains generalized user information as well as supplemental information to the List of Replaceable Parts contained in Section 5.

List of Abbreviations and Symbols

A or amp	ampere	hf	high frequency	(+) or pos	positive
ac	alternating current	Hz	hertz	pot	potentiometer
af	audio frequency	IC	integrated circuit	p-p	peak-to-peak
a/d	analog-to-digital	if	intermediate frequency	ppm	parts per million
assy	assembly	in	inch(es)	PROM	programmable read-only memory
AWG	american wire gauge	intl	internal	psi	pound-force per square inch
B	bel	I/O	input/output	RAM	random-access memory
bcd	binary coded decimal	k	kilo (10 ³)	rf	radio frequency
°C	Celsius	kHz	kilohertz	rms	root mean square
cap	capacitor	kΩ	kilohm(s)	ROM	read-only memory
ccw	counterclockwise	kV	kilovolt(s)	s or sec	second (time)
cer	ceramic	lf	low frequency	scope	oscilloscope
cermet	ceramic to metal(seal)	LED	light-emitting diode	SH	shield
ckt	circuit	LSB	least significant bit	Si	silicon
cm	centimeter	LSD	least significant digit	serno	serial number
cmrr	common mode rejection ratio	M	mega (10 ⁶)	sr	shift register
comp	composition	m	milli (10 ⁻³)	Ta	tantalum
cont	continue	mA	milliampere(s)	tb	terminal board
crt	cathode-ray tube	max	maximum	tc	temperature coefficient or temperature compensating
cw	clockwise	mf	metal film	tcxo	temperature compensated crystal oscillator
d/a	digital-to-analog	MHz	megahertz	tp	test point
dac	digital-to-analog converter	min	minimum	u or μ	micro (10 ⁻⁶)
dB	decibel	mm	millimeter	uhf	ultra high frequency
dc	direct current	ms	millisecond	us or μs	microsecond(s) (10 ⁻⁶)
dmm	digital multimeter	MSB	most significant bit	uut	unit under test
dvm	digital voltmeter	MSD	most significant digit	V	volt
elect	electrolytic	MTBF	mean time between failures	v	voltage
ext	external	MTTR	mean time to repair	var	variable
F	farad	mV	millivolt(s)	vco	voltage controlled oscillator
°F	Fahrenheit	mv	multivibrator	vhf	very high frequency
FET	Field-effect transistor	MΩ	megohm(s)	vlf	very low frequency
ff	flip-flop	n	nano (10 ⁻⁹)	W	watt(s)
freq	frequency	na	not applicable	ww	wire wound
FSN	federal stock number	NC	normally closed	xfmr	transformer
g	gram	(-) or neg	negative	xstr	transistor
G	giga (10 ⁹)	NO	normally open	xtal	crystal
gd	guard	ns	nanosecond	xtio	crystal oscillator
Ge	germanium	opnl ampl	operational amplifier	Ω	ohm(s)
GHz	gigahertz	p	pico (10 ⁻¹²)	μ	micro (10 ⁻⁶)
gmV	guaranteed minimum value	para	paragaph		
gnd	ground	pcb	printed circuit board		
H	henry	pF	picofarad		
hd	heavy duty	pn	part number		

Federal Supply Codes for Manufacturers (cont)

20891 Self-Organizing Systems, Inc Dallas, Texas	28480 Hewlett Packard Co. Corporate HQ Palo Alto, California	43543 Nytronics Inc. Transformer Co. Div. Geneva, New York	70903 Beiden Corp. Geneva, Illinois
21604 Buchey Stamping Co Columbus, Ohio	28520 Heyman Mfg. Co. Kenilworth, New Jersey	44655 Ohmite Mfg. Co. Skokie, Illinois	71002 Birnback Radio Co., Inc. Freeport, New York
21845 Solitron Devices Inc. Transistor Division Riviera Beach, Florida	29083 Monsanto. Co., Inc. Santa Clara, California	49671 RCA Corp. New York, New York	71400 Busmann Mfg. Div. of McGraw-Edison Co. Saint Louis, Missouri
22767 ITT Semiconductors Palo Alto, California	29604 Stackpole Components Co Raleigh, North Carolina	49956 Raytheon Company Lexington, Massachusetts	71450 CTS Corp. Elkhart, Indiana
23050 Product Comp Corp Mount Vernon, New York	30148 AB Enterprise Inc Ahoskie, North Carolina	50088 Mostek Corp. Carrollton, Texas	71468 ITT Cannon Electric Inc. Santa Ana, California
23732 Tracor Inc Rockville, Maryland	30323 Illinois Tool Works, Inc Chicago, Illinois	50579 Litronix Inc Cupertino, California	71482 Clare, C.P. & Co. Chicago, Illinois
23880 Stanford Applied Engrng Santa Clara, California	31091 Optimax Inc. Colmar, Pennsylvania	51605 Scientific Components Inc. Linden, New Jersey	71590 Centrelab Electronics Div. of Globe Union Inc. Milwaukee, Wisconsin
23936 Pamotor Div Wm J Purdy Co Burlingame, California	32539 Mura Corp Great Neck, New York	53021 Sangamo Electric Co. Springfield, Illinois	71707 Coto Coil Co., Inc. Providence, Rhode Island
24248 Replaced by 94222	32767 Griffith Plastic Corp Burlingame, California	54294 Cutler-Hammer Inc. formerly Shallcross, A Cutter-Hammer Co. Seima, North Carolina	71744 Chicago Miniature Lamp Works Chicago, Illinois
24355 Analog Devices Inc Norwood, Massachusetts	32879 Advanced Mechanical Components Northridge, California	55026 Simpson Electric Co. Div. of Am Gage and Mach. Co. Elgin, Illinois	71785 TRW Electronics Components Cinch Connector Operations Div. Elk Grove Village Chicago, Illinois
24655 General Radio Concord, Massachusetts	32897 Erie Technological Products Inc Frequency Control Div Carlisle, Pennsylvania	56289 Sprague Electric Co. North Adams, Massachusetts	72005 Wilber B. Driver Co. Newark, New Jersey
24759 Lenda Fugie Electronics Inc South Plainfield, New Jersey	32997 Bourns Inc Trimpot Products Division Riverside, California	58474 Superior Electric Co. Bristol, Connecticut	72092 Replaced by 06980
25088 Siemen Corp Islip, New Jersey	33173 General Electric Co Products Dept Owensboro, Kentucky	60399 Torin Corp. formerly Torrington Mfg. Co. Torrington, Connecticut	72136 Electro Motive Mfg. Co., Williamantic, Connecticut
25403 Amperex Electronic Corp Semiconductor & Micro-Circuits Div Slatersville, Rhode Island	34333 Silicon General Westminster, California	63743 Ward Leonard Electric Co., Inc. Mount Vernon, New York	72259 Nytronics Inc. Pelham Manor, New Jersey
27014 National Semiconductor Corp Santa Clara, California	34335 Advanced Micro Devices Sunnyvale, California	64834 West Mfg. Co. San Francisco, California	72619 Dialight Div. Amperex Electronic Corp. Brooklyn, New York
27264 Molex Products Downers Grove, Illinois	34802 Electromotive Inc Kenilworth, New Jersey	65092 Weston Instruments Inc. Newark, New Jersey	72653 G.C. Electronics Div. of Hydrometals, Inc. Brooklyn, New York
28213 Minnesota Mining & Mfg Co Consumer Products Div St Paul, Minnesota	37942 P.R. Mallory & Co Inc Indianapolis, Indiana	66150 Winslow Tele-Tronics Inc. Eaton Town, New Jersey	72665 Replaced by 90303
28425 Serv-Link formerly Bohannon Industries Fort Worth, Texas	42498 National Radio Melrose, Massachusetts	70485 Atlantic India Rubber Works Chicago, Illinois	72794 Dzus Fastener Co., Inc. West Islip, New York
28478 Detroit Controls Div Detroit Corporation Milwaukee, Wisconsin		70563 Amperite Company Union City, New Jersey	72928 Gulton Ind, Inc. Gudeman Div. Chicago, Illinois

Federal Supply Codes for Manufacturers (cont)

72982 Erie Tech. Products Inc. Erie, Pennsylvania	75382 Kulka Electric Corp. Mount Vernon, New York	80583 Hammarlund Mfg. Co., Inc. Red Bank, New Jersey	83594 Burroughs Corp. Electronic Components Div. Plainfield, New Jersey
73138 Bechman Instrument Inc. Helipot Division Fullerton, California	75915 Littlefuse Inc. Des Plaines, Illinois	80640 Arnold Stevens, Inc. South Boston, Massachusetts	83740 Union Carbide Corp. Battery Products Div. formerly Consumer Products Div. New York, New York
73293 Hughes Aircraft Co. Electron Dynamics Div. Torrance, California	76854 Oak Industries Inc. Switch Div. Crystal Lake, Illinois	81073 Grayhill, Inc. La Grange, Illinois	84171 Arco Electronics Great Neck, New York
73445 Amperex Electronic Corp. Hicksville, New York	77342 AMF Inc. Potter & Brumfield Div. Princeton, Indiana	81312 Winchester Electronics Div. of Litton Industries Inc. Oakville, Connecticut	84411 TRW Electronic Components TRW Capacitors Ogallala, Nebraska
73559 Carling Electric Inc. West Hartford, Connecticut	77638 General Instrument Corp. Rectifier Division Brooklyn, New York	81483 Therm-O-Disc Inc. Mansfield, Ohio	84613 Fuse Indicator Corp. Rockville, Maryland
73586 Circle F Industries Trenton, New Jersey	77969 Rubbercraft Corp. of CA. LTD. Torrance, California	81483 International Rectifier Corp. Los Angeles, California	84682 Essex International Inc. Industrial Wire Div. Peabody, Massachusetts
73734 Federal Screw Products, Inc. Chicago, Illinois	78189 Shakeproof Div. of Illinois Tool Works Inc. Elgin, Illinois	81590 Korry Mfg. Co. Seattle, Washington	86577 Precision Metal Products of Malden Inc. Stoneham, Massachusetts
73743 Fischer Special Mfg. Co. Cincinnati, Ohio	78277 Sigma Instruments, Inc. South Braintree, Massachusetts	81741 Chicago Lock Co. Chicago, Illinois	86684 Radio Corp. of America Electronic Components Div. Harrison, New Jersey
73899 JFD Electronics Co Components Corp Brooklyn, New York	78488 Stackpole Carbon Co Saint Marys, Pennsylvania	82305 Palmer Electronics Corp. South Gate, California	86928 Seastrom Mfg. Co., Inc. Glendale, California
73949 Guardian Electric Mfg. Co. Chicago, Illinois	78553 Eaton Corp. Engineered Fastener Div. Tinnerman Plant Cleveland, Ohio	82389 Switchcraft Inc. Chicago, Illinois	87034 Illuminated Products Inc. Subsidiary of Oak Industries Inc. Anaheim, California
74199 Quan Nichols Co Chicago, Illinois	79136 Waldes Kohinoor Inc. Long Island City, New York	82415 North American Phillips Controls Corp. Frederick, Maryland	88219 Gould Inc. Industrial Div. Trenton, New Jersey
74217 Radio Switch Corp Marlboro, New Jersey	79497 Western Rubber Company Goshen, Indiana	82872 Roanwell Corp. New York, New York	88245 Litton Systems Inc. Useco Div. Van Nuys, California
74276 Signalite Div. General Instrument Corp Neptune, New Jersey	79963 Zierick Mfg. Corp. Mt. Kisko, New York	82877 Rotron Inc. Woodstock, New York	88419 Cornell-Dubilier Electronic Div. Federal Pacific Co. Fuquay-Varian, North Carolina
74306 Piezo Crystal Co Carlisle, Pennsylvania	80031 Electro-Midland Corp. Mepco Div. A North American Phillips Co. Norristown, New Jersey	82879 ITT Royal Electric Div. Pawtucket, Rhode Island	88486 Plastic Wire & Cable Jewitt City, Connecticut
74542 Hoyt Elect Instr Works Penacook, New Hampshire	80145 LFE Corp., Process Control Div. formerly API Instrument Co Chesterland, Ohio	83003 Varo Inc. Garland, Texas	88690 Replaced by 04217
74970 Johnson E.F. Co Waseca, Minnesota	80183 Use 56289 Sprague Products North Adams, Massachusetts	83058 The Carr Co., United Can Div. of TRW Cambridge, Massachusetts	89536 John Fluke Mfg. Co., Inc. Seattle, Washington
75042 TRW Electronics Components IRC Fixed Resistors Philadelphia, Pennsylvania	80294 Bourns Inc., Instrument Div. Riverside, California	83298 Bendix Corp. Electric Power Div. Eatontown, New Jersey	89730 G.E. Co., Newark Lamp Works Newark, New Jersey
75376 Kurz-Kasch Inc Dayton, Ohio		83330 Herman H. Smith, Inc. Brooklyn, New York	
75378 CTS Knights Inc. Sandwich, Illinois		83478 Rubbercraft Corp. of America, Inc. West Haven, Connecticut	

Federal Supply Codes for Manufacturers

00213 Nytronics Comp. Group Inc Subsidiary of Nytronics Inc. Formerly Sage Electronics Rochester, New York	02660 Bunker Ramo Corp., Conn Div. Formerly Amphenol-Borg Electric Corp. Broadview, Illinois	04946 Standard Wire & Cable Los Angeles, California	06751 Components, Inc. Semcor Div. Phoenix, Arizona
00327 Weiwyn International, Inc Westlake, Ohio	02799 Aero Capacitors, Inc. Chatsworth, California	05082 Replaced by 94988	06860 Gould Automotive Div. City of Industry, California
00656 Aerovox Corp New Bedford, Massachusetts	03508 General Electric Co Semiconductor Products Syracuse, New York	05236 Jonathan Mfg. Co. Fullerton, California	06961 Vernitron Corp., Piezo Electric Div. Formerly Clevite Corp., Piezo Electric Div. Bedford, Ohio
00686 Film Capacitors, Inc. Passaic, New Jersey	03614 Replaced by 71400	05245 Components Corp. now Corcom, Inc. Chicago, Illinois	06980 Eimac Div. Varian Associates San Carlos, California
00779 AMP Inc Harrisburg, Pennsylvania	03651 Replaced by 44655	05277 Westinghouse Electric Corp. Semiconductor Div. Youngwood, Pennsylvania	07047 The Ross Milton Co. South Hampton, Pennsylvania
01121 Allen-Bradley Co Milwaukee, Wisconsin	03797 Eidema Div Genisco Technology Corp Compton, California	05278 Replaced by 43543	07115 Replaced by 14674
01281 TRW Electronic Comp Semiconductor Operations Lawndale, California	03877 Transistron Electronic Corp. Wakfield, Massachusetts	05279 Southwest Machine & Plastic Co. Glendora, California	07138 Westinghouse Electric Corp., Electronic Tube Div. Horsehead, New York
01295 Texas Instruments Inc Semiconductor Group Dallas, Texas	03888 KDI Pyrofilm Corp. Whippany, New Jersey	05397 Union Carbide Corp. Materials Systems Div. New York, New York	07233 TRW Electronic Components Cinch Graphic City of Industry, California
01537 Motorola Communications & Electronics Inc Franklin Park, Illinois	03911 Clairex Electronics Div Clairex Corp Mt Vernon, New York	05571 Use 56289 Sprague Electric Co. Pacific Div Los Angeles, California	07256 Silicon Transistor Corp. Div. of BBF Group Inc. Chelmsford, Massachusetts
01686 RCL Electronics Inc Manchester, New Hampshire	03980 Muirhead Inc Mountainside, New Jersey	05574 Viking Industries Chatsworth, California	07261 Aumet Corp. Culver City, California
01730 Replaced by 73586	04009 Arrow Hart Inc Hartford, Connecticut	05704 Replaced by 16258	07263 Fairchild Semiconductor Div. of Fairchild Camera & Instrument Corp. Mountain View, California
01884 Use 56289 Sprague Electric Co Dearborn Electronic Div Lockwood, Florida	04062 Replaced by 72136	05820 Wakfield Engineering Inc. Wakfield, Massachusetts	07344 Bircher Co., Inc. Rochester, New York
02114 Ferroxcube Corp Saugerties, New York	04202 Replaced by 81312	06001 General Electric Co Electronic Capacitor & Battery Products Dept. Columbia, South Carolina	07597 Burdny Corp. Tape/Cable Div. Rochester, New York
02131 General Instrument Corp Harris ASW Div Westwood, Maine	04217 Essex International Inc Wire & Cable Div Anaheim, California	06136 Replaced by 63743	07792 Lerma Engineering Corp. Northampton, Massachusetts
02395 Rason Mfg. Co Brooklyn, New York	04221 Aemco, Div. of Midtex Inc Mankato, Minnesota	06383 Panduit Corp. Tinley Park, Illinois	07910 Teledyne Semiconductor Formerly Continental Device Hawthorne, California
02533 Sneigrove CR Co Ltd Don Mills, Ontario, Canada M3B 1M2	04222 AVX Ceramics Div AVX Corp Myrtle Beach, Florida	06473 Bunker Ramo Corp Amphenol SAMS Div Chatsworth, California	07933 Use 49956 Raytheon Co. Semiconductor Div. HQ Mountain View, California
02606 Fenwal Labs Div. of Travenal Labs Morton Grove, Illinois	04423 Telonic Industries Laguna Beach, California	06555 Beede Electrical Instrument Co. Penacook, New Hampshire	08225 Industro Transistor Corp. Long Island City, New York
	04645 Replaced by 75376	06739 Electron Corp. Littleton, Colorado	
	04713 Motorola Inc Semiconductor Products Phoenix, Arizona	06743 Clevite Corp. Cleveland, Ohio	

Federal Supply Codes for Manufacturers (cont)

08261 Spectra Strip Corp. Garden Grove, California	11726 Qualidyne Corp. Santa Clara, California	13606 Use 56289 Sprague Electric Co. Transistor Div. Concord, New Hampshire	16299 Corning Glass Electronic Components Div. Raleigh, North Carolina
08530 Reliance Mica Corp. Brooklyn, New York	12014 Chicago Rivet & Machine Co. Bellwood, Illinois	13839 Replaced by 23732	16332 Replaced by 28478
08806 General Electric Co. Miniature Lamp Products Dept Cleveland, Ohio	12040 National Semiconductor Corp. Danbury, Connecticut	14099 Semtech Corp. Newbury Park, California	16473 Cambridge Scientific Ind. Div. of Chemed Corporation Cambridge, Maryland
08863 Nylomatic Corp. Norrisville, Pennsylvania	12060 Diodes, Inc. Chatsworth, California	14140 Edison Electronic Div. Mc Gray-Edison Co. Manchester, New Hampshire	16742 Paramount Plastics Fabricators, Inc. Downey, California
08988 Use 53085 Skottie Electronics Inc Archbald, Pennsylvania	12136 Philadelphia Handle Co. Camden, New Jersey	14193 Cal-R-Inc. formerly California Resistor, Corp. Santa Monica, California	16758 Delco Electronics Div. of General Motors Corp. Kokomo, Indiana
09214 G.E. Co. Semi-Conductor Products Dept Power Semi-Conductor Products OPN Sec Auburn, New York	12300 Potter-Brumfield Div. AMF Canada LTD Guelph, Ontario, Canada	14298 American Components, Inc. an Insilco Co. Conshohocken, Pennsylvania	17001 Replaced by 71468
09353 C and K Components Watertown, Massachusetts	12323 Presin Co., Inc Shelton, Connecticut	14655 Cornell-Dublier Electronics Division of Federal Pacific Electric Co. Govt. Control Dept. Newark, New Jersey	17069 Circuit Structures Lab. Burbank, California
09423 Scientific Components, Inc. Santa Barbara, California	12327 Freeway Corp. formerly Freeway Washer & Stamping Co. Cleveland, Ohio	14752 Electro Cube Inc. San Gabriel, California	17338 High Pressure Eng. Co., Inc. Oklahoma City, Oklahoma
09922 Burndy Corp. Norwalk, Connecticut	12443 The Budd Co. Polychem Products Plastic Products Div. Bridgeport, Pennsylvania	14869 Replaced by 96853	17545 Atlantic Semiconductors, Inc. Asbury Park, New Jersey
09969 Dale Electronics Inc. Yankton, S. Dakota	12615 U.S. Terminals Inc Cincinnati, Ohio	14936 General Instrument Corp. Semi Conductor Products Group Hicksville, New York	17856 Siliconix, Inc. Santa Clara, California
10059 Barker Engineering Corp Formerly Amerace, Amerace ESNA Corp. Kenilworth, New Jersey	12617 Hamlin Inc Lake Mills, Wisconsin	15636 Elec-Trol Inc. Saugus, California	17870 Replaced by 14140
11236 CTS of Berne Berne, Indiana	12697 Clarostat Mfg. Co. Dover, New Hampshire	15801 Fenwal Electronics Inc. Div. of Kidde Walter and Co., Inc. Framingham, Massachusetts	18178 Vactec Inc. Maryland Heights, Missouri
11237 CTS Keene Inc Paso Robles, California	12749 James Electronics Chicago, Illinois	15818 Teledyne Semiconductors, formerly Amelco Semiconductor Mountain View, California	18324 Signetics Corp. Sunnyvale, California
11358 CBS Electronic Div. Columbia Broadcasting System Newburyport, Minnesota	12856 Micrometals Sierra Madre, California	15849 Litton Systems Inc. Useco Div. formerly Useco Inc. Van Nuys, California	18612 Vishay Resistor Products Div. Vishay Intertechnology Inc. Malvern, Pennsylvania
11403 Best Products Co Chicago, Illinois	12954 Dickson Electronics Corp Scottsdale, Arizona	15898 International Business Machines Corp Essex Junction, Vermont	18736 Voltronics Corp. Hanover, New Jersey
11503 Keystone Columbia Inc Warren, Michigan	12969 Unitrode Corp Watertown, Massachusetts	15909 Replaced by 14140	18927 GTE Sylvania Inc. Precision Material Group. Parts Division Titusville, Pennsylvania
11532 Teledyne Relays Hawthorne, California	13103 Thermalloy Co., Inc Dallas, Texas	16258 Space-Lok Inc. Burbank, California	19451 Perine Machinery & Supply Co. Seattle, Washington
11711 General Instrument Corp. Rectifier Division Hicksville, New York	13327 Solitron Devices Inc Tappan, New York		19701 Electro-Midland Corp. Mepco-Electra Inc. Mineral Wells, Texas
	13511 Amphenol Cadre Div Bunker-Ramo Corp. Los Gatos, California		20584 Enochs Mfg. Inc. Indianapolis, Indiana

Federal Supply Codes for Manufacturers (cont)

90201 Mallory Capacitor Co. Div. of P.R. Mallory Co., Inc. Indianapolis, Indiana	91836 King's Electronics Co., Inc. Tuckahoe, New York	95354 Methode Mfg. Corp. Rolling Meadows, Illinois	98291 Seallectro Corp. Mamaroneck, New York
90211 Use 56365 Square D Co. Chicago, Illinois	91929 Honeywell Inc. Micro Switch Div. Freeport, Illinois	95712 Bendix Corp. Electrical Components Div. Microwave Devices Plant Franklin, Indiana	98388 Royal Industries Products Div. San Diego, California
90215 Best Stamp & Mfg. Co. Kansas City, Missouri	91934 Miller Electric Co., Inc. Div. of Aunet Woonsocket, Rhode Island	95987 Weckesser Co. Inc. Chicago, Illinois	98743 Replaced by 12749
90303 Mallory Battery Co. Div. of Mallory Co., Inc. Tarrytown, New York	92194 Alpha Wire Corp. Elizabeth, New Jersey	96733 San Fernando Electric Mfg. Co. San Fernando, California	98925 Replaced by 14433
91094 Essex International Inc. Suglex/IWP Div. Newmarket, New Hampshire	93332 Sylvania Electric Products Semiconductor Products Div. Woburn, Massachusetts	96853 Gulton Industries Inc. Measurement and Controls Div. formerly Rustrak Instruments Co. Manchester, New Hampshire	99120 Plastic Capacitors, Inc. Chicago, Illinois
91293 Johanson Mfg. Co. Boonton, New Jersey	94145 Replaced by 49956	96881 Thomson Industries, Inc. Manhasset, New York	99217 Bell Industries Elect. Comp. Div. formerly Southern Elect. Div. Burbank, California
91407 Replaced by 58474	94154 Use 94988 Wagner Electric Corp. Tung-Sol Div. Newark, New Jersey	97540 Master Mobile Mounts, Div. of Whitehall Electronics Corp. Ft. Meyers, Florida	99392 STM Oakland, California
91502 Associated Machine Santa Clara, California	94222 Southco Inc. formerly South Chester Corp. Lester, Pennsylvania	97913 Industrial Electronic Hardware Corp. New York, New York	99515 ITT Jennings Monrovia Plant Div. of ITT Jennings formerly Marshall Industries Capacitor Div. Monrovia, California
91506 Augat Inc. Attleboro, Massachusetts	95146 Aico Electronic Products Inc. Lawrence, Massachusetts	97945 Penwalt Corp. SS White Industrial Products Div. Piscataway, New Jersey	99779 Use 29587 Bunker-Ramo Corp. Barnes Div. Landsdowne, Pennsylvania
91637 Dale Electronics Inc Columbus, Nebraska	95263 Leecraft Mfg. Co. Long Island City, New York	97966 Replaced by 11358	99800 American Precision Industries Inc. Delevan Division East Aurora, New York
91662 Elco Corp. Willow Grove, Pennsylvania	95264 Replaced by 98278	98094 Replaced by 49956	99942 Centrelab Semiconductor Centrelab Electronics Div. of Globe-Union Inc. El Monte, California
91737 Use 71468 Gremar Mfg. Co., Inc. ITT Cannon/Gremar Santa Ana, California	95275 Vitramon Inc. Bridgeport, Connecticut	98159 Rubber-Teck, Inc. Gardena, California	99942 Toyo Electronics (R-Ohm Corp.) Irvine, California
91802 Industrial Devices, Inc. Edgewater, New Jersey	95303 RCA Corp Receiving Tube Div. Cincinnati, Ohio	98278 Malco A Microdot Co., Inc. Connector & Cable Div. Pasadena, California	National Connector Minneapolis, Minnesota
91833 Keystone Electronics Corp. New York, New York	95348 Gordo's Corp. Bloomfield, New Jersey		



Appendix 7A Manual Change Information

INTRODUCTION

This appendix contains information necessary to backdate the manual to conform with earlier pcb configurations. To identify the configuration of the pcb's used in your instrument, refer to the revision letter (marked in ink) on the component side of each pcb assembly. Table 7A-1 defines the assembly revision levels documented in this manual with an X.

NEWER INSTRUMENTS

As changes and improvements are made to the instrument they are identified by incrementing the revision letter marked on the affected pcb assembly. These changes are documented on a supplemental change/errata sheet which, when applicable, is inserted at the front of the manual.

OLDER INSTRUMENTS

To backdate this manual to conform with earlier assembly revision levels, perform the changes indicated in Table 7A-1.

Table 7A-1. Manual Status and Backdating Information

Ref Or Option No.	Assembly Name	Fluke Part No.	* To adapt manual to earlier rev configurations perform changes in descending order (by no.), ending with change under desired rev letter																	
			-	A	B	C	D	E	F	G	H	J	K	L	M	N	P			
A1	Main PCB Assembly, 8920A-4001	456889	1	5	7	X														
A1	Main PCB Assembly, 8921A-4011	471904	1	5	7	X														
A1A1	Display PCB Assembly, 8920A/8921A-4002T	456921				6	X													
A2	AC PCB Assembly, 8920A/8921A-4003T	456905			X															
-003	Counter Output Option 892XA-4013T	471599		2	3	4	X													
-004	Logarithmic Analog Option 892XA-4014T	471581		X																

* X = The PCB revision levels documented in this manual.
 ● = These revision letters were never used in the instrument.
 - = No revision letter on the PCB.

CHANGE #1, ECO #11698

1. On Table 5-2, A1, 8920A Main PCB Assembly, delete the following items:
XF1-1, XR204.
2. On Table 5-3, A1 8921A Main PCB Assembly, delete the following items:
XF1-1, XR204.

CHANGE #2, ECO #11586

- a. Replace "E402" with "OUTPUT", on Figure 603-4.
- b. Delete Item C415 from Figures 603-4 and 8-5.
- c. Delete Item C415 from Table 603-3.

CHANGE #3, ECO #11637

1. Delete Item L404 from Figure 603-4 and 8-5.
2. Delete Item L404 from Table 603-3.

CHANGE #4 ECO #11784

On Table 603-5, -003 Counter Output Option, make the following changes:

ADD: R401/Res, comp. 100 \pm 5% m 1/4W/147926/01121/CB105/1

MP9/Bus Wire #20/^{212704/}~~115469~~/89536/^{/212704/}~~115469~~/AR

On Figure 603-6 and 8-5, make the indicated changes:

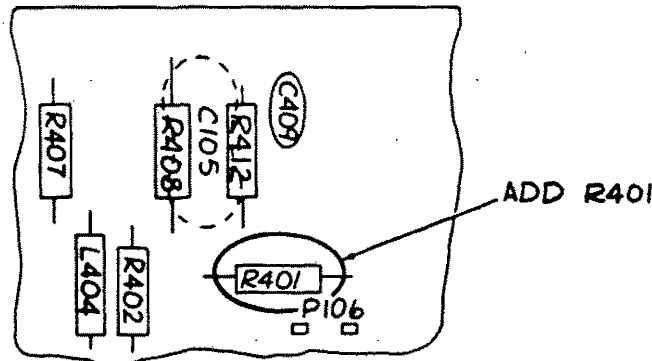

On Figure 8-5, make indicated changes:

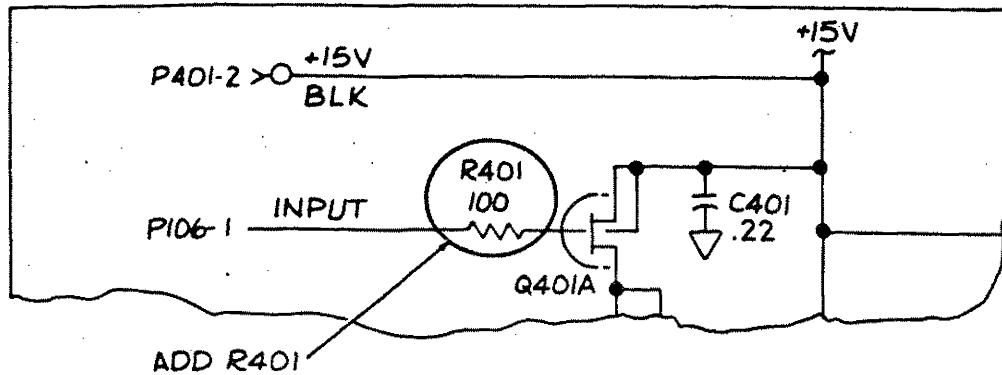

CHANGE #5 ECO #11812

On Table 5-2, A1 8920A Main PCB Assembly, make the following changes:

DELETE: C213/Cap, cer, 10.000 pF $\pm 20\%$, 100V/149153/56289/C023B10F103M/Ref

CHANGE TOT QTY of C204 from 4 to 3.

On Figure 4-5, 5-2, Calibration and Test Point Locations, and 8-1, A1 8920A Main PCB Assembly (Sht 2 of 3) make the indicated changes:

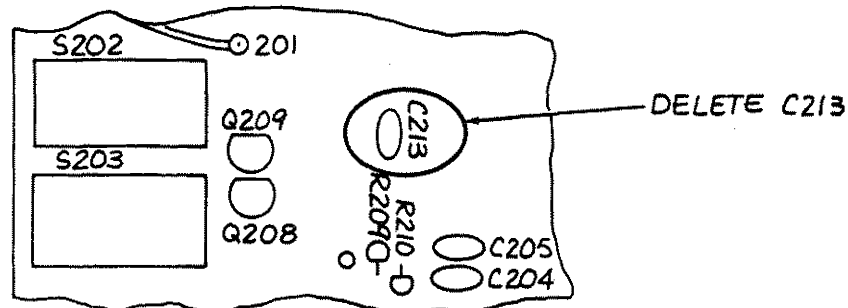

On Figure 8-1, A1 8920A Main PCB Assembly (Sht 3 of 3) make the indicated changes:

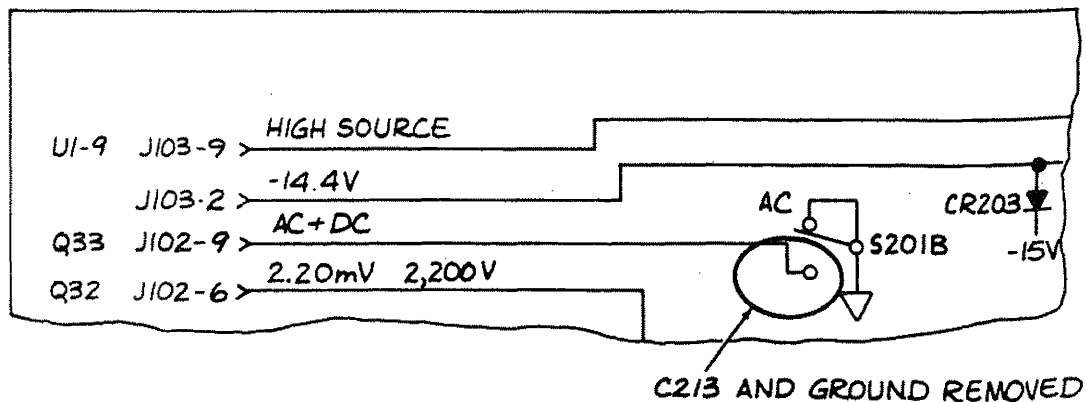

ECO #11792

Hardware change on 8921A-4011 Assembly. no action required in manual

CHANGE #6 ECO #11863

On Table 5-4, A1A1 8920A/8921A Display PCB Assembly make the following changes:

DS301/Display LED/^{453340/29083/MAN3630A/}~~495457/28480/QDSP3507/1~~

DS302-DS305/Display LED/^{453332/29083/MAN3620A/}~~495440/28480/QDSP3515/4~~

CHANGE #7 ECO #11866

Hardware change on 8920A-4001 and 8921A-4011 Assembly. no action required in manual.

Section 8

Schematic Diagrams

TABLE OF CONTENTS

FIGURE	TITLE	PAGE
8-1	A1 8920A Main PCB Assembly	8-2
8-2	A1 8921A Main PCB Assembly	8-4
8-3	A1A1 8920A/8921A Display PCB Assembly	8-6
8-4	A2 8920A/8921A AC PCB Assembly	8-8
8-5	-003 Counter Output Option	8-12
8-6	-004 Logarithmic Analog Output Option	8-14

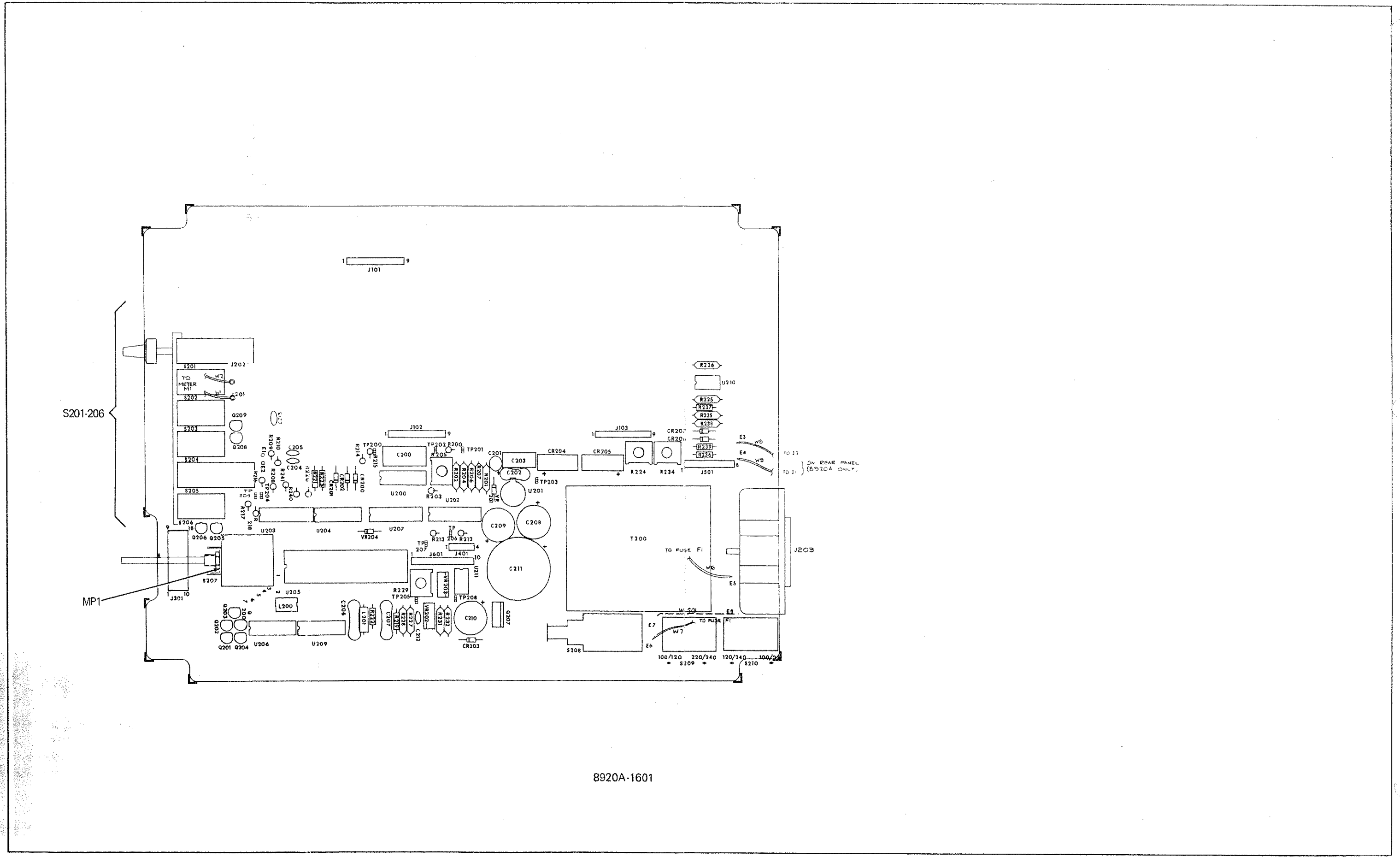

8920A-1601

Figure 8-1. A1 8920A Main PCB Assembly

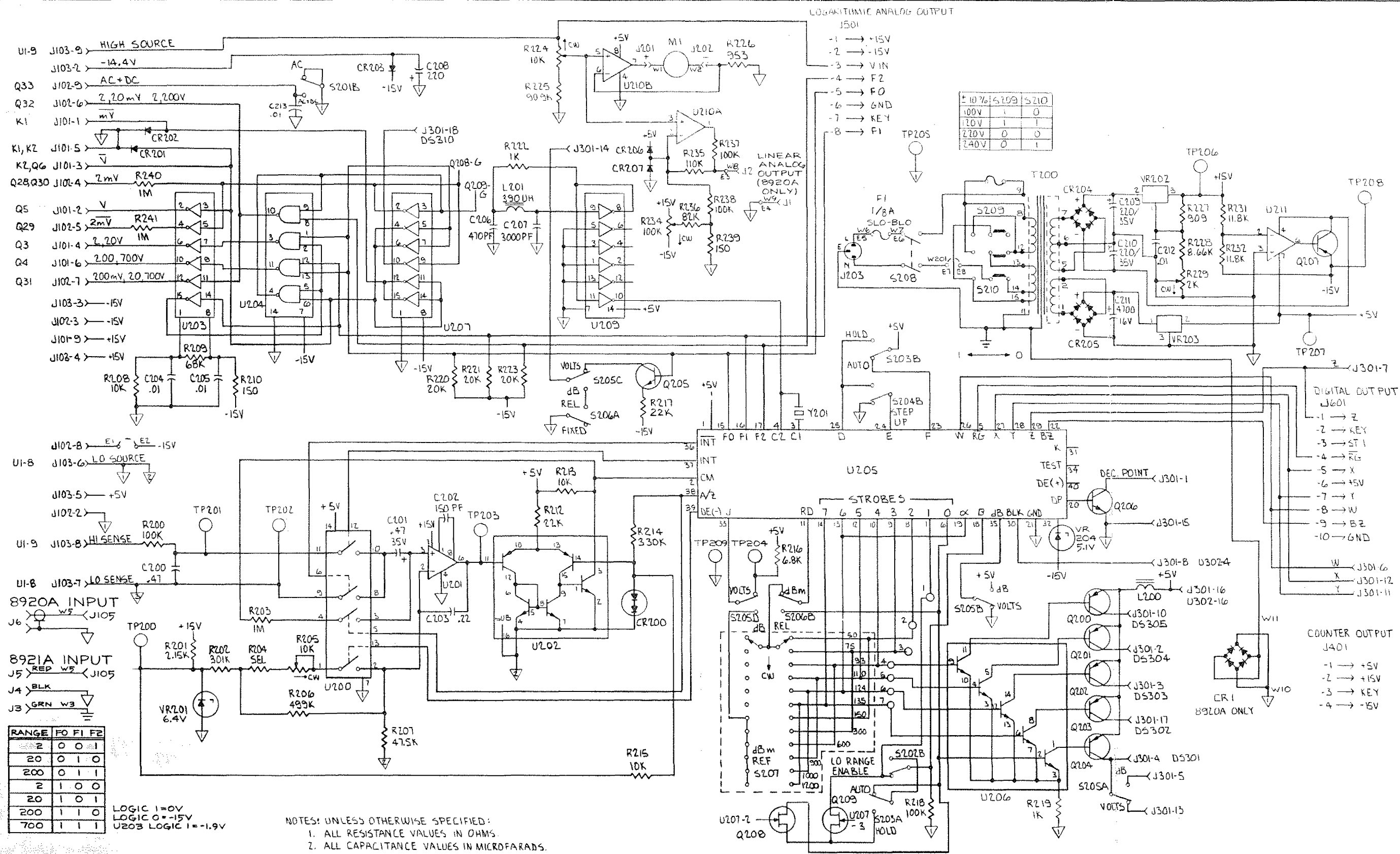
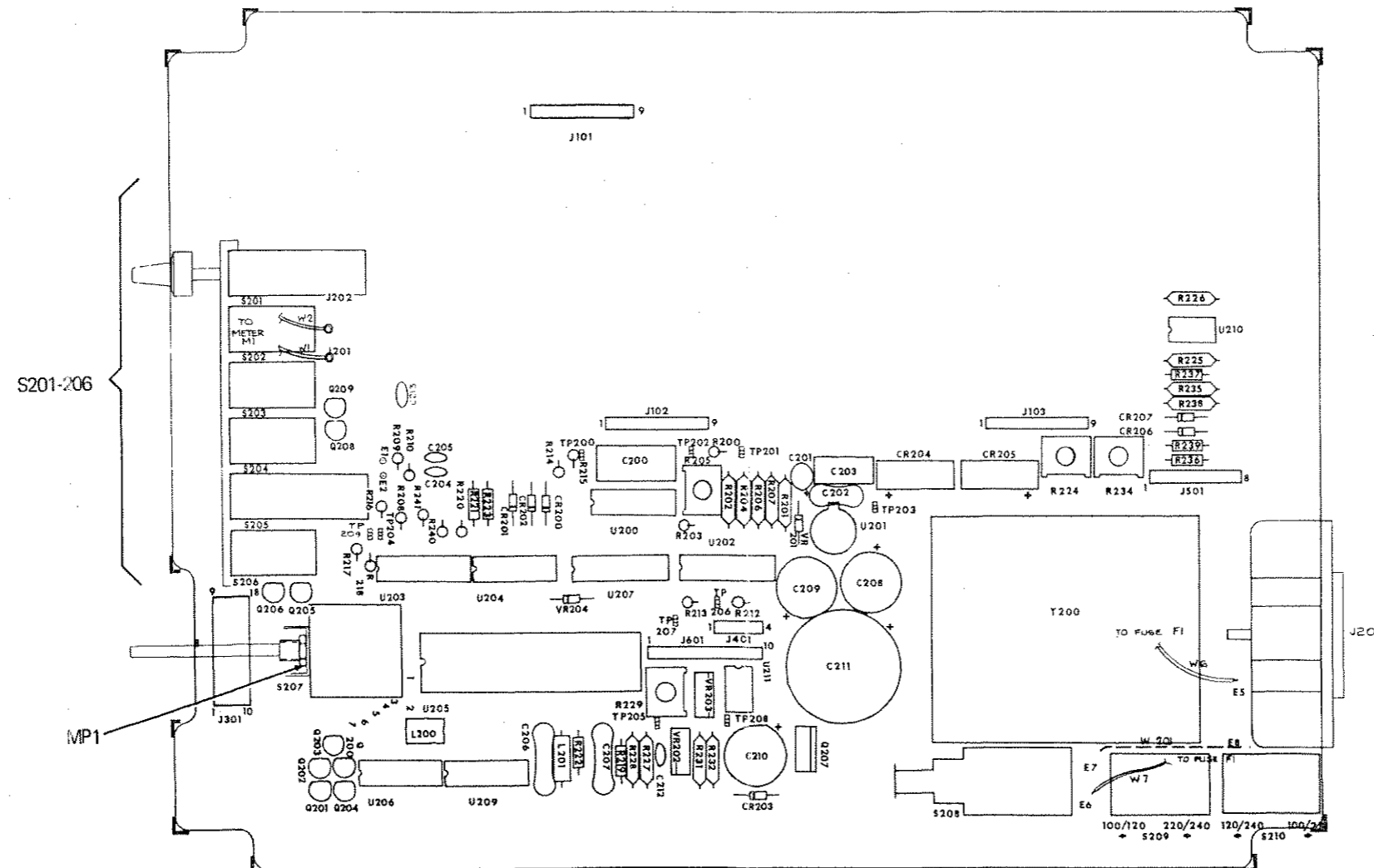
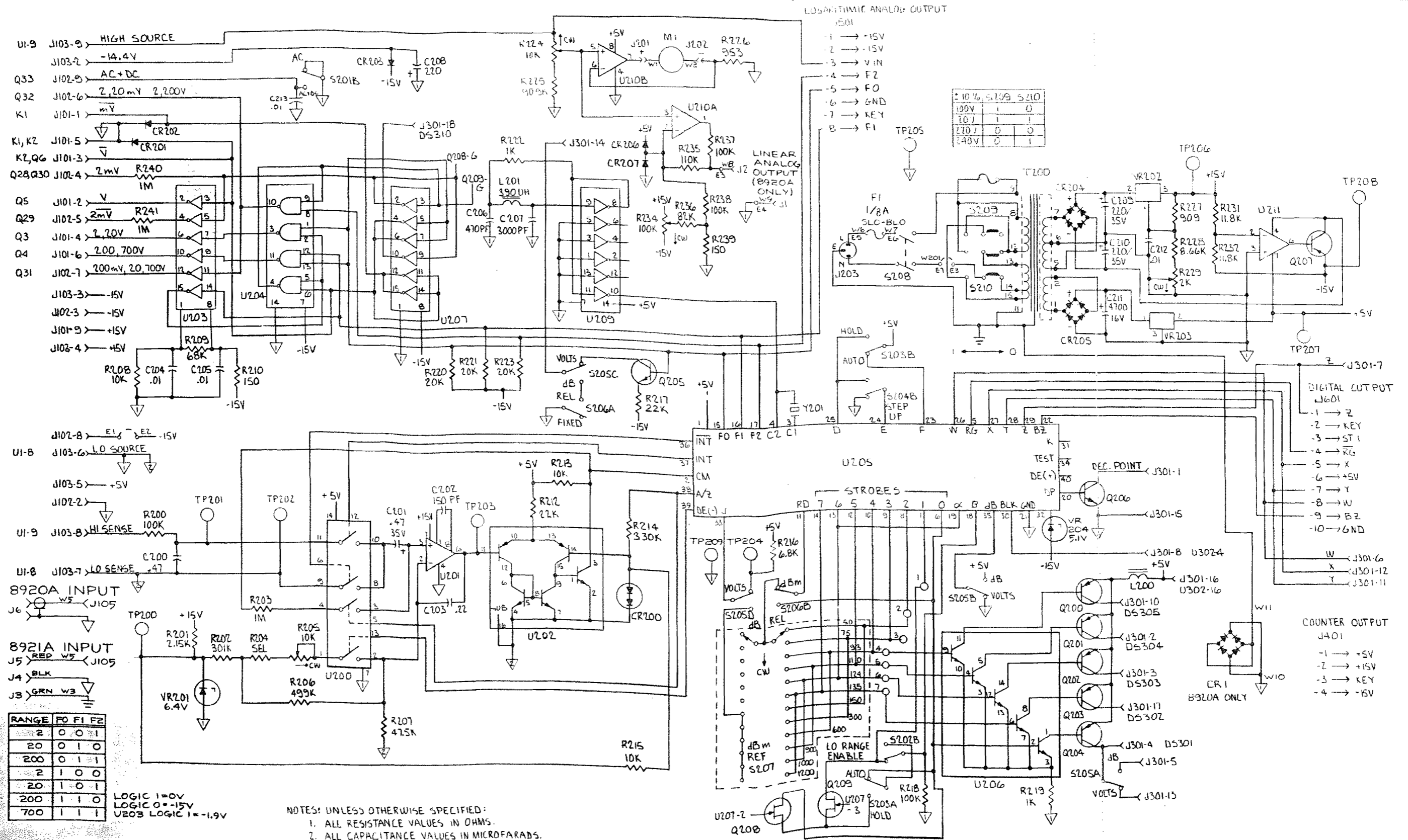

Figure 8-1. A1 8920A Main PCB Assembly (cont)



8920A-1601

Figure 8-2. A1 8921A Main PCB Assembly



RANGE	FO	FI	FZ
2	0	0	1
20	0	1	0
200	0	1	1
2	1	0	0
20	1	0	1
200	1	1	0
700	1	1	1

LOGIC 1=0V
 LOGIC 0=-15V
 U203 LOGIC 1=-1.9V

8920A-1001

Figure 8-2. A1 8921A Main PCB Assembly (cont)

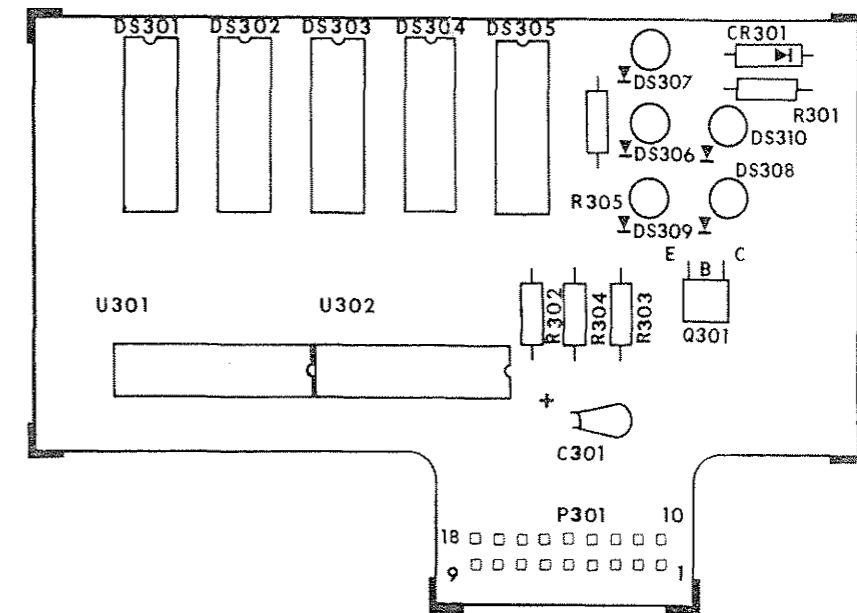

8920A-1602

Figure 8-3. A1A1 8920A/8921A Display PCB Assembly

NOTES: UNLESS OTHERWISE SPECIFIED:
 1. ALL RESISTANCE VALUES IN OHMS.
 2. ALL CAPACITANCE VALUES IN MICROFARADS.

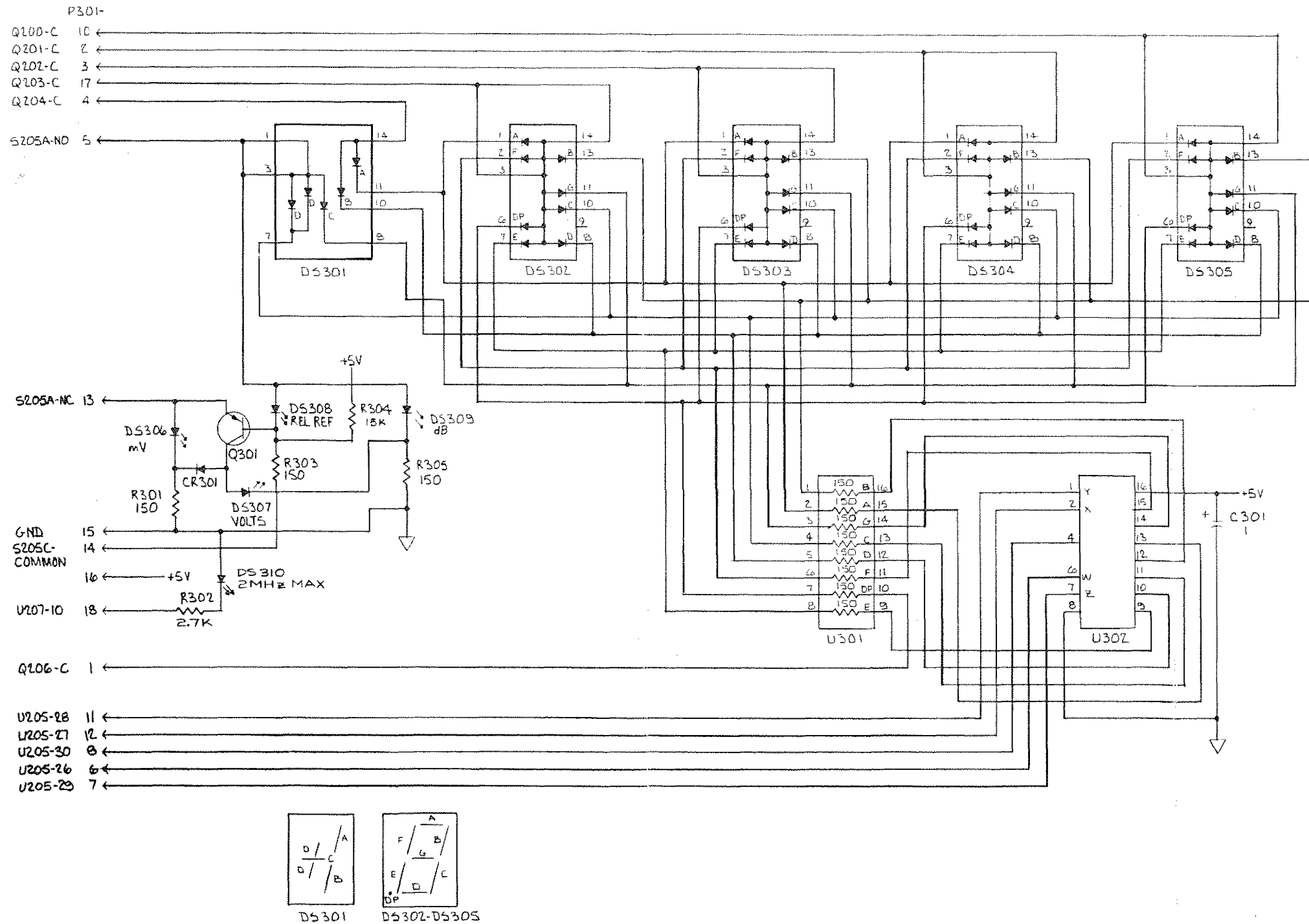

8920A-1002

Figure 8-3. A1A1 8920A/8921A Display PCB Assembly (cont)

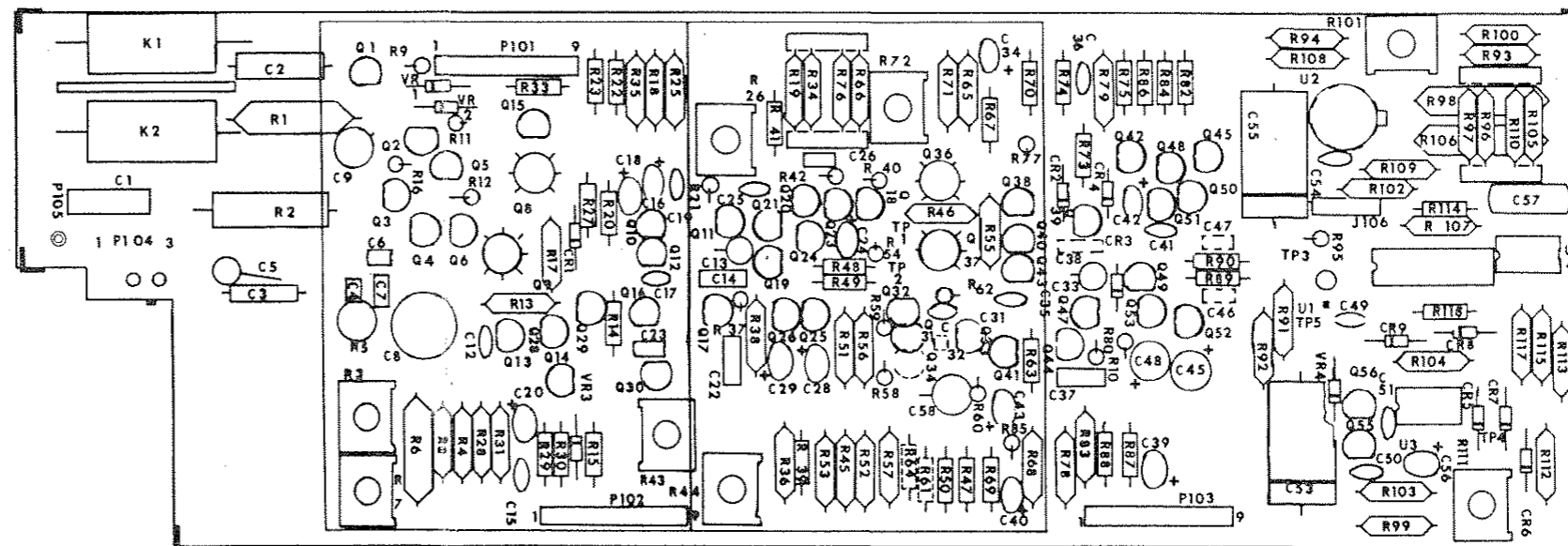

8920A-1603

Figure 8-4. A2 8920A/8921A AC PCB Assembly

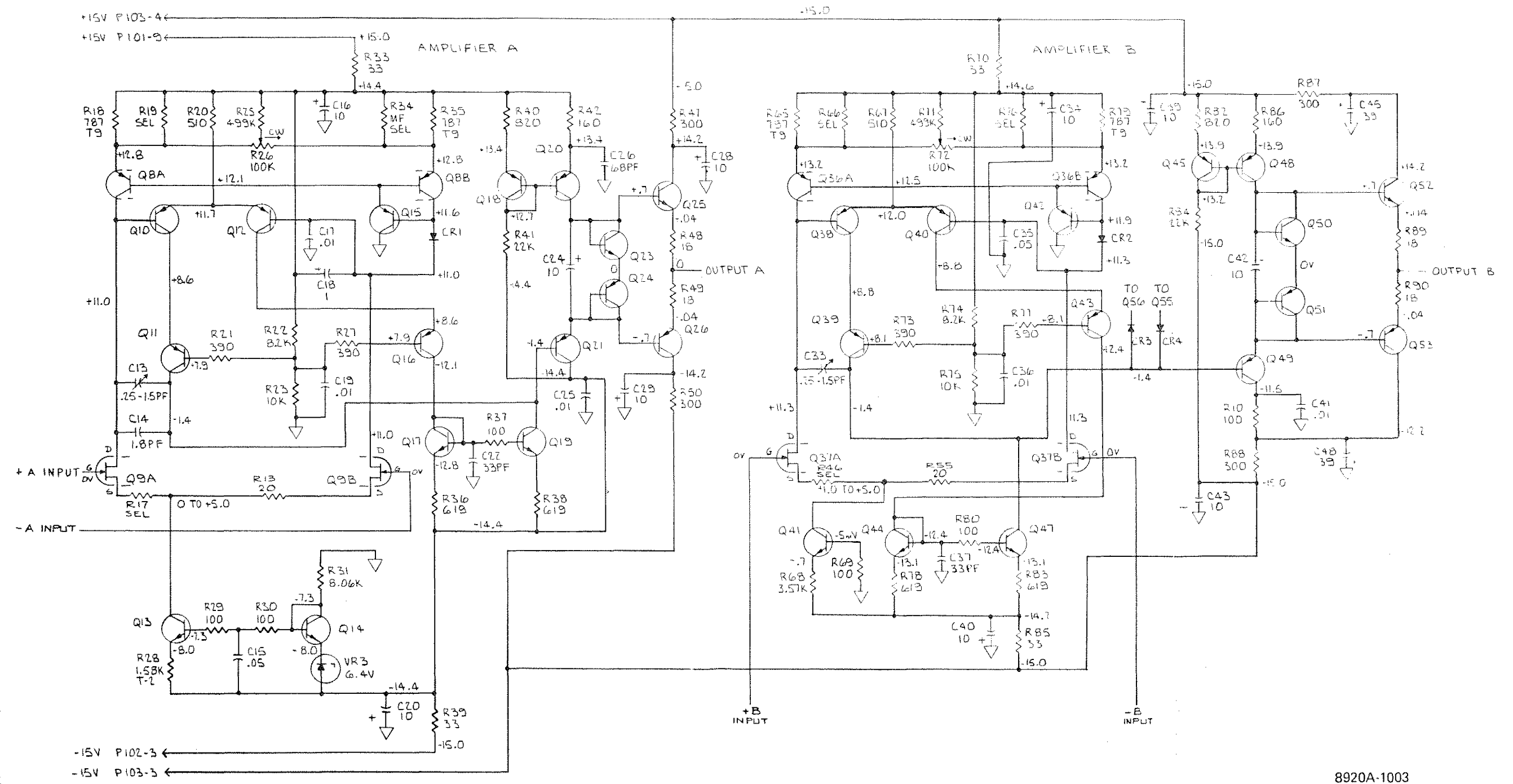

8920A-1003

Figure 8-4. A2 8920A/8921A AC PCB Assembly (cont)

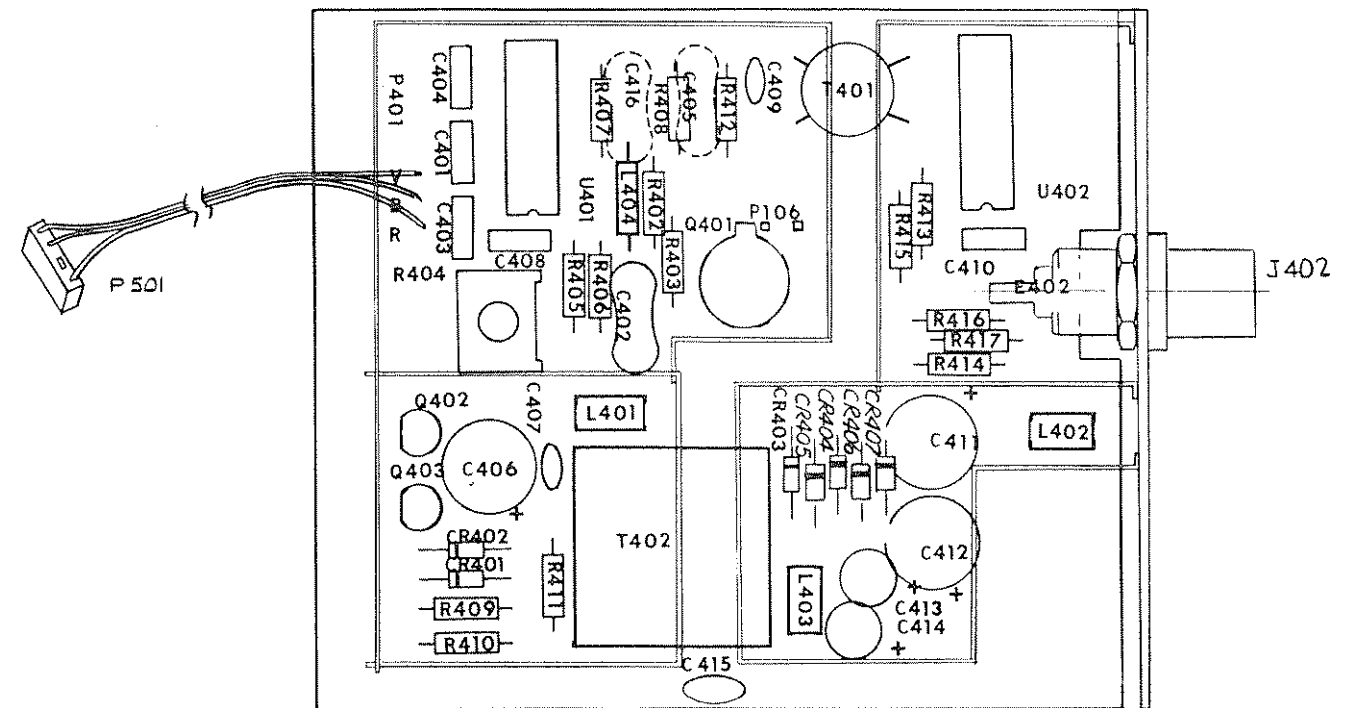

892XA-1613

Figure 8-5. -003 Counter Output Option

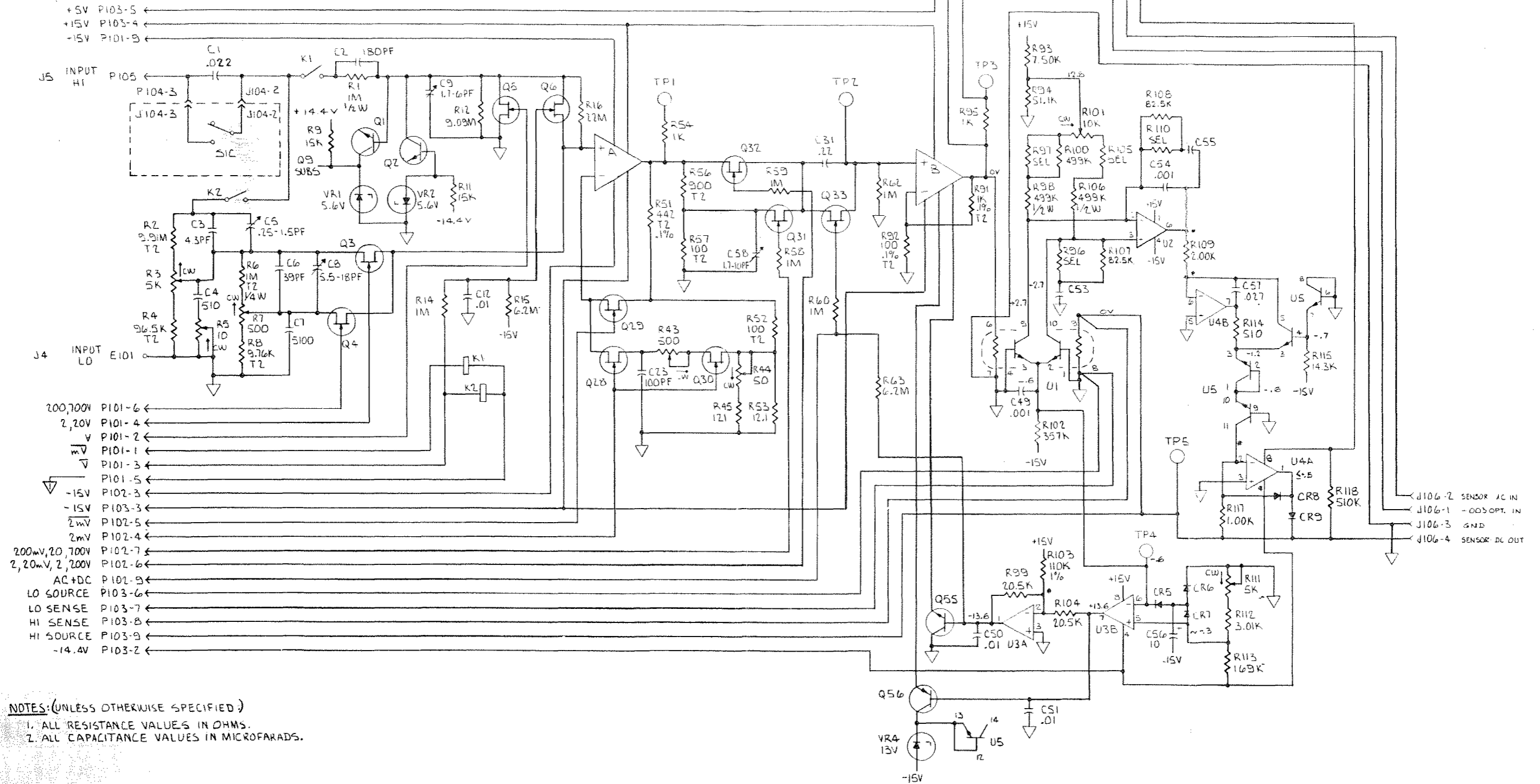

8920A-1003

Figure 8-4. A2 8920A/8921A AC PCB Assembly (cont)

This page left blank intentionally

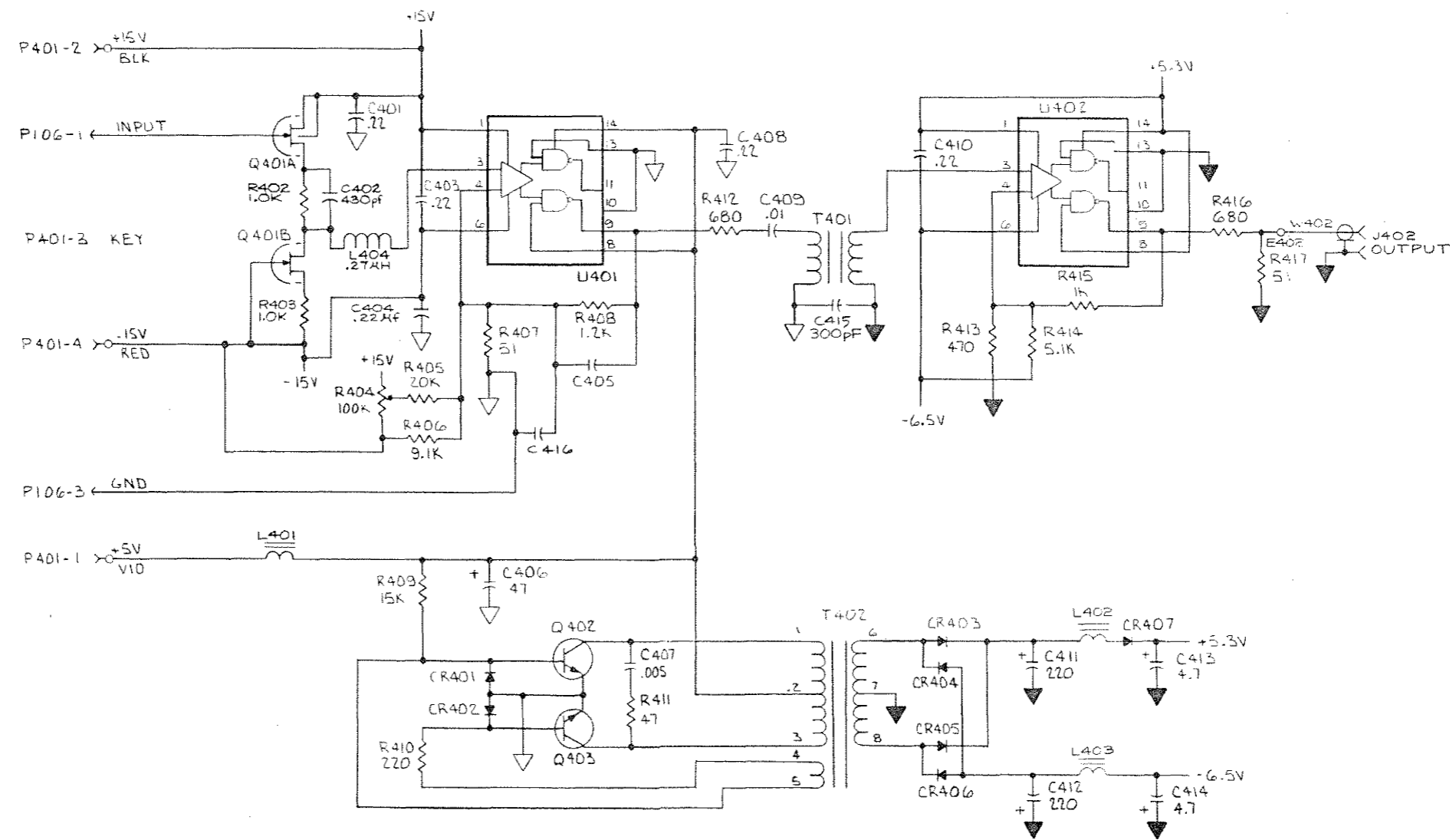

892X-1013

Figure 8-5. -003 Counter Output Option (cont)

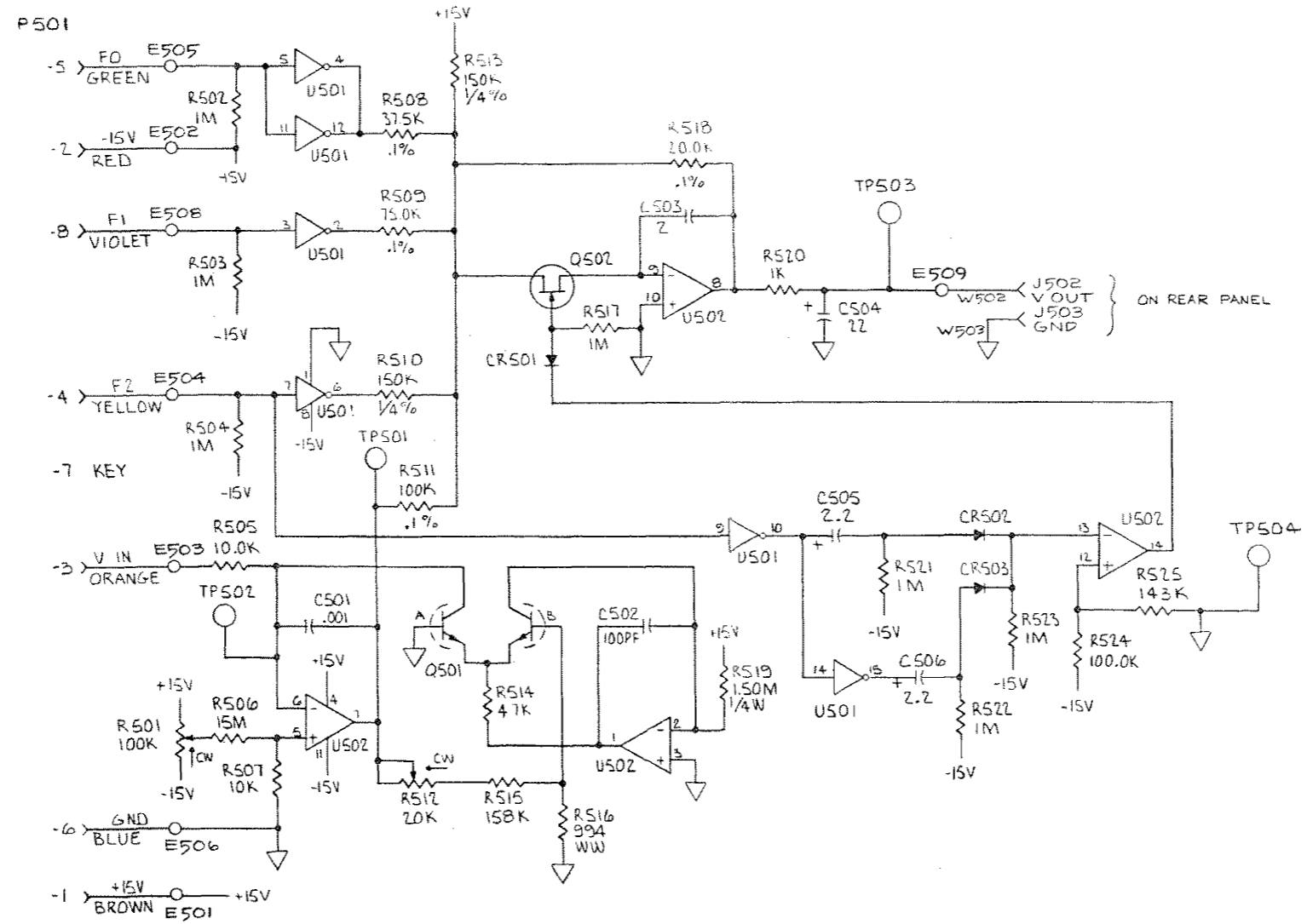

NOTES: UNLESS OTHERWISE SPECIFIED
1 ALL RESISTANCE VALUES IN OHMS
2 ALL CAPACITANCE VALUES IN MICROFARAD.

8920A-1014

Figure 8-6. -004 Logarithmic Analog Output Option (cont)

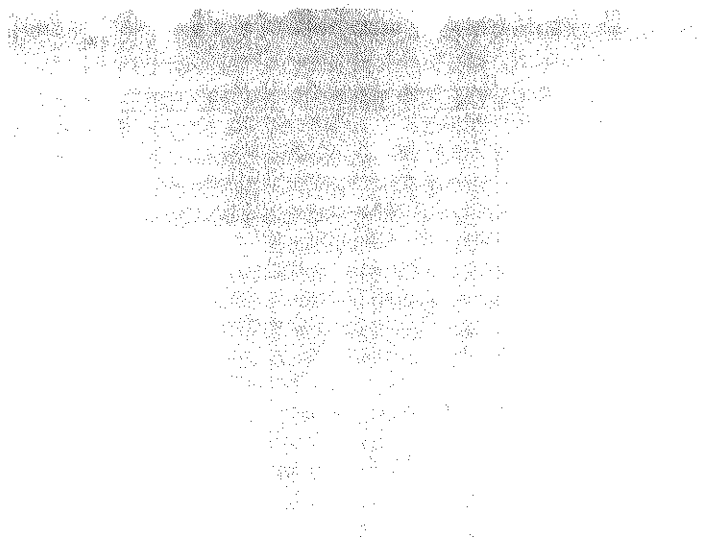

Faint, illegible text or markings in the top right corner.



AL, Huntsville
John Fluke Mfg. Co., Inc.
4920 Corporate Drive
Suite J
Huntsville, AL 35805-6202
(205) 830-9671

AZ, Tempe
John Fluke Mfg. Co., Inc.
2211 S. 48th Street
Suite B
Tempe, AZ 85282
(602) 438-8314

CA, Burbank
John Fluke Mfg. Co., Inc.
2020 N. Lincoln Street
Burbank, CA 91504
(213) 849-7181

Irvine
P.O. Box 19676
Irvine, CA 92713-9676
16969 Von Karman
Suite 100
Irvine, CA 92714
(714) 863-9031

San Diego
John Fluke Mfg. Co., Inc.
4540 Kearny Villa Road
Suite 115
San Diego, CA 92123
(619) 292-7656

Santa Clara
John Fluke Mfg. Co., Inc.
2300 Walsh Ave., Bldg. K
Santa Clara, CA 95051
(408) 727-0513

CO, Denver
John Fluke Mfg. Co., Inc.
14180 E. Evans Ave.
Aurora, CO 80014
(303) 695-1000

CT, Hartford
John Fluke Mfg. Co., Inc.
Glen Lochen East
41-C New London Turnpike
Glastonbury, CT 06033
(203) 659-3541

FL, Clearwater
(813) 799-0087

Orlando
John Fluke Mfg. Co., Inc.
940 N. Fern Creek Ave.
Orlando, FL 32803
(305) 896-4881

Tampa
(813) 251-9211

GA, Atlanta
John Fluke Mfg. Co., Inc.
2600 Deik Road
Suite 150
Marietta, GA 30067
(404) 953-4747

IL, Chicago
John Fluke Mfg. Co., Inc.
1150 W. Euclid Avenue
Palatine, IL 60067
(312) 398-0850
(312) 392-9510

IN, Indianapolis
John Fluke Mfg. Co., Inc.
8777 Purdue Road
Suite 101
Indianapolis, IN 46268
(317) 875-7870

MA, Billerica
John Fluke Mfg. Co., Inc.
900 Middlesex Turnpike
Building 8
Billerica, MA 01821
(617) 663-2400

MD, Baltimore
(301) 792-7060

Rockville
John Fluke Mfg. Co., Inc.
5640 Fishers Lane
Rockville, MD 20852
(301) 770-1570

MI, Detroit
John Fluke Mfg. Co., Inc.
33031 Schoolcraft
Livonia, MI 48150
(313) 522-9140

MN, Bloomington
John Fluke Mfg. Co., Inc.
1801 E. 79th St., Suite 9
Bloomington, MN 55420
(612) 854-5526

MO, St. Louis
John Fluke Mfg. Co., Inc.
2029 Woodland Parkway
Suite 105
St. Louis, MO 63146
(314) 993-3805

NC, Greensboro
John Fluke Mfg. Co., Inc.
1310 Beaman Place
Greensboro, NC 27408
(919) 273-1918

NJ, Paramus
John Fluke Mfg. Co., Inc.
P.O. Box 930
Paramus, NJ 07653-0930
West 75 Century Road
Paramus, NJ 07652
(201) 262-9550

NY, Rochester
John Fluke Mfg. Co., Inc.
4515 Culver Road
Rochester, NY 14622
(716) 323-1400

OH, Cleveland
John Fluke Mfg. Co., Inc.
7830 Freeway Circle
Middleburg Heights, OH 44130
(216) 234-4540

Columbus
(614) 889-5715

Dayton
John Fluke Mfg. Co., Inc.
4756 Fishburg Rd.
Dayton, OH 45424
(513) 233-2238

PA, Malvern
John Fluke Mfg. Co., Inc.
200 Lindenwood Drive
Malvern, PA 19355
(215) 647-9550

TX, Dallas
John Fluke Mfg. Co., Inc.
1801 Royal Lane
Suite 307
Dallas, TX 75229
(214) 869-0311

San Antonio
John Fluke Mfg. Co., Inc.
10417 Gulfdale
San Antonio, TX 78216
(512) 340-1011

WA, Seattle
John Fluke Mfg. Co., Inc.
5020 148th Ave. N.E.
Suite 110
Redmond, WA 98052
(206) 881-6966

Service Center Areas

CA, Burbank (213) 849-7181
CA, Santa Clara (408) 727-0513
CO, Denver (303) 695-1000
FL, Orlando (305) 896-4881
IL, Chicago (312) 392-9510
MA, Billerica (617) 663-2400
MD, Rockville (301) 770-1570
NJ, Paramus (201) 262-9550
TX, Dallas (214) 869-0311
WA, Everett (206) 356-5560

For more information on Fluke products or Sales Offices you may dial (800) 426-0361 toll-free in most of the U.S.A.
From Alaska, Hawaii, or Washington phone (206) 356-5400. From Canada and other countries phone (206) 356-5500.



John Fluke Mfg. Co., Inc., P.O. Box C9090, Everett, WA 98206
Fluke (Holland) B.V., P.O. Box 2269, 5600 CG, Eindhoven, The Netherlands. Phone (040) 458045, TLX 51846
Litho in U.S.A. 11/85

U.S. SALES AREAS for all Fluke products

Argentina •
Coasin S.A.
Virrey del Pino 4071 DEP E-1
1430 CAP FED
Buenos Aires, Argentina
Tel: (1) 552-5248, TLX: (390) 22284

Australia •
Elmeasco Instruments Pty. Ltd.
P.O. Box 30
Concord, N.S.W. 2137
Australia
Tel: (2) 736-2888, TLX: (790) AA25887

Elmeasco Instruments Pty. Ltd.
P.O. Box 623
12 Maroondah Highway
Ringwood, Victoria 3134
Australia
Tel: (3) 879-2322, TLX: (790) AA36206

Elmeasco Instruments Pty. Ltd.
Professional Suites Bldg.
G.P.O. Box 2360
Brisbane 4001, Australia
Tel: (7) 369-8688, TLX: (790) AA44062

Elmeasco Instruments Pty. Ltd.
G.P.O. Box 1240
Adelaide, South Australia 5001
Tel: (8) 271-1839

Elmeasco Instruments Pty. Ltd.
P.O. Box 95
Gosnells, West Australia 6110
Australia
Tel: (9) 398-3362

Austria •
Walter Rekrirsch Elektronische
Geräte GmbH & Co.
Vertrieb KG
Obachgasse 28
1220 Vienna, Austria
Tel: (222) 235555, TLX: (847) 134759

Bahrain
Basma
P.O. Box 5701
Manama, Bahrain
Tel: 251-364; TLX: (955) 9003

Bangladesh •
Motherland Corporation
24 Hathkola Road, Tikatuli
Dacca-3, Bangladesh
Tel: 257249 or 255776
TLX: (950) 642022

Belgium •
Fluke (Belgium) S.A./N.V.
6 Rue de Geneve
1140 Brussels
Belgium
Tel: (2) 2164090, TLX: (846) 26312

Bolivia •
Coasin Bolivia S.R.L.
Casilla 7295
La Paz, Bolivia
Tel: (2) 40962, TLX: (336) 5255

Brazil •
Hi-Tek Electronica Ltda.
Al. Amazonas 422,
Alphaville, Barueri,
CEP 06400, Sao Paulo, Brazil
Tel: (11) 421-5477, TLX: (391) 01135589

Brunei •
Rank O'Connor's Berhad
No. 8 Bld D
Sufri Shophouse Complex
Mile 1 Jalan Tutong
Bandar Seri Begawan
Negara Brunei Darussalam
Tel: (2) 23109 or 23557
TLX: (799) 2265 RANKOC

Canada •
Allan Crawford Assoc., Ltd.
5835 Coopers Avenue
Mississauga, Ontario
L4Z 1Y2 Canada
Tel: (416) 890-2010, TLX: 0696 1235

Allan Crawford Assoc., Ltd.
7018 Cote de Liesse
St. Laurent, Quebec
H4T 1E7 Canada
Tel: (514) 731-8564
TLX: 05824944

Allan Crawford Assoc., Ltd.
2625 Queensview Drive
Ottawa, Ontario
K2B 8K2 Canada
Tel: (613) 596-9300, TLX: 05336600

Allan Crawford Assoc., Ltd.
Suite No. 106
4180 Lougheed Hwy.
Burnaby, British Columbia
V5C 6A7 Canada
Tel: (604) 294-1326, TLX: 0454247

Allan Crawford Assoc., Ltd.
1935 30th Avenue, N.E.
Calgary, Alberta
T2E 6Z5 Canada
Tel: (403) 230-1341, TLX: 03821186

Allan Crawford Assoc., Ltd.
800 Windmill Road
Suite 205
Dartmouth, N.S.
B3B 1L1 Canada
Tel: (902) 463-8640

Chile •
Intronica Chile, Ltda
Manuel Montt 024-Of. D
Casilla 16228
Santiago 9, Chile
Tel: (2) 44940, TLX: (332) 240301

China, Peoples Republic of •
Fluke International Corp.
P.O. Box C9090 M/S 206A
Everett, WA 98206 U.S.A.
Tel: (206) 356-5511
TLX: 185103 FLUKE UT

Colombia •
Sistemas E Instrumentacion, Ltda.
Carrera 13, No. 37-43, Of. 401
Ap. Aereo 29583
Bogota DE, Colombia
Tel: 232-4532, TLX: (396) 45787

Cyprus •
Chris Radiovision, Ltd.
P.O. Box 1989
Nicosia, Cyprus
Tel: (21) 66121, TLX: (826) 2395

Cyprus, Northern
Ucok Buroteknik
2C & 2D Muftu Ziyai Street
Lefkosa, Northern Cyprus
Mersin 10, Turkey
Tel: (741) 357-20-71777
TLX: (821) 57267

Czechoslovakia •
Amtest Associates Ltd.
Clarence House
31 Clarence Street
Staines, Middlesex TW18 4SY
England
Tel: (784) 63555, TLX: (851) 928855

Denmark •
Tage Olsen A/S
Ballerup Byvej 222
2750 Ballerup
Denmark
Tel: (2) 658111, TLX: (855) 35293

Ecuador •
Proteco Coasin Cia., Ltda.
P.O. Box 228-A
Ave. 12 de Octubre 2285
y Orellana
Quito, Ecuador
Tel: (2) 529684, TLX: (393) 2865

Proteco Coasin Cia., Ltda.
P.O. Box 9733
Ave. Principal No. 204
y Calle Segunda
Urbanizacion Miraflores
Guayaquil, Ecuador
Tel: (4) 387519

Egypt and Sudan •
Electronic Engineering Liaison Office
P.O. Box 2891 Horreya
Heliopolis, Cairo
Egypt
Tel: (2) 695705, TLX: (927) 22782

England •
Fluke GB, Ltd.
Colonial Way
Watford, Herts.
WD2 4TT England
Tel: (923) 40511, TLX: (851) 934583

Fiji •
Awa Fiji
47 Forster Road
Walu Bay
Suva, Fiji
Tel: 312079, TLX: (792) FJ2347

Finland •
Instrumentarium Elektronii oy
P.O. Box 64
02631 Espoo 63
Finland
Tel: (0) 5281, TLX: (857) 124426

France •
M.B. Electronique S.A.
606, Rue Fourney
P.O. Box 31
78530 BUC, France
Tel: (3) 956-8131, TLX: (842) 695414

German Democratic Republic •
Amtest Associates Ltd.
Clarence House, 31 Clarence St
Staines, Middlesex TW18 4SY
United Kingdom
Tel: (784) 63555, TLX: (851) 928855

Germany, West •
Fluke (Deutschland) GmbH
Oskar-Messter-Strasse 18
8045 Ismaning/Munich
West Germany
Tel: (89) 96050, TLX: (841) 0522472
Rapifax: 49-89-9605166

Fluke (Deutschland) GmbH
Viertriebsburo - Dusseldorf
Meineckestrasse 53, D-4000 Dusseldorf-30
West Germany
Tel: (211) 450831, TLX: (841) 17-2114233

Fluke (Deutschland) GmbH
Vertriebsburo - Hamburg
Habichthorst 42
D-2000 Hamburg 61
West Germany
Tel: (40) 5519031, TLX: (841) 02174556

Greece •
Hellenic Scientific Representations Ltd.
11, Vratsida Street
Athens 612, Greece
Tel: (1) 711140, TLX: (863) 219330

Hong Kong •
Schmidt & Co (H.K.), Ltd
18th Floor, Great Eagle Centre
23 Harbour Road
Wanchai, Hong Kong
Tel: (5) 8330-222
TLX: (780) 74766 or (780) 76762

Hungary •
Amtest Associates Ltd.
Clarence House, 31 Clarence St
Staines, Middlesex TW18 4SY
United Kingdom
Tel: (784) 63555, TLX: (851) 928855

India •
Hinditron Services Pvt. Ltd.
69/A.L. Jagmohandas Marg
Bombay 400 006, India
Tel: (22) 8121316, 8125344, TLX: (953) 112326

Hinditron Services Pvt. Ltd.
8th Main Road
33/44A Raj Mahal Vistas Extension
Bangalore 560 080, India
Tel: (910) 33139, 367289; TLX: (953) 845741

Hinditron Services Pvt. Ltd.
5th Floor, "Castle House"
5/1A, Hungerford St
Calcutta 700 017, India
Tel: 33-434628, TLX: 21-4153

Hinditron Services Pvt. Ltd.
204-5-6 Hemkunt Tower
98 Nehru Place
New Delhi, 110019, India
Tel: (910) 640380, TLX: (953) 3161458

Hinditron Services Pvt. Ltd.
1-1-58/1 to 1-1-58/11
Sarojini Devi Road
Secunderabad 500 003, India
Tel: (842) 821117, TLX: (953) 1556973

Indonesia •
P.T. Dwi Tunggal Jaya Sakti
P.O. Box 4435
Wisma Harapan Bldg. 14th
Jl. Jend. Sudirman Kav. 34
Jakarta Pusat, Indonesia
Tel: (2) 584685, TLX: (796) 47308

Ireland •
Euro Instruments & Electronics Ltd.
Euro House
Swords Road, Santry
Dublin 9, Ireland
Tel: (1) 425666, TLX: (851) 31821

Israel •
R.D.T. Electronics Engineering Ltd.
P.O. Box 43137
Tel Aviv 61430
Israel
Tel: (3) 483211, TLX: (922) 32143

Italy •
Sistrel S.p.A.
Via Pelizza da Volpedo 59
20092 Cinisello Balsamo
Milan, Italy
Tel: (2) 6181893, TLX: (843) 334643

Sistrel S.p.A.
Via Giuseppe Armellini No. 39
00143 Rome, Italy
Tel: (6) 591-5551, TLX: (843) 680356

Sistrel S.p.A.
Via Cinta
Parco S. Paolo 35
80126 Naples, Italy
Tel: (81) 7879700

Japan •
John Fluke Mfg. Co., Inc.
Japan Branch
Sumitomo Higashi Shinbashi Bldg.
1-1-11 Hamamatsucho
Minato-ku, Tokyo 105, Japan
Tel: (3) 434-0181, TLX: (781) 2424331
FAX: 81-3-434-0170

John Fluke Mfg. Co., Inc.
Japan Branch
Katsushige Building
2-45 Kohraibashi
Higashi-ku, Osaka 541
Japan
Tel: (6) 229-0871



John Fluke Mfg. Co., Inc. / PO Box C9090 / Everett, WA 98206 / (206) 356 5400

Litho in U.S.A. 11/85

Korea, Republic of
Myoung Corporation
Rm #1501, Sinsong Bldg
25-4 Yeouido-Dong, Young Deung Po-ku
Seoul 150, Korea
Tel: (2) 784-9942, TLX: K24283

Kuwait
Al Bahar International Group
P.O. Box 26672 Safat
Kuwait, Arabian Gulf
Tel: 848601, 847598, TLX: (959) 44822

Lebanon and Jordan
Mabek (Electronics Division)
P.O. Box 13-5657
Beirut, Lebanon
Tel: 812523, TLX: (923) 22889

Malaysia
Mecomb Malaysia SND BHD
Lot 20, Jalan 225
P.O. Box 24
Petaling Jaya, Malaysia
Tel: (3) 743422, TLX: (784) MA37764

Malta
Fabian Enterprises
20, Msida Road
Gzira, Malta
Tel: 513283/40216, TLX: (838) 1837

Mexico
Industrial S.A. (Mexel)
Diagonal No. 27
Entre Calle de Eugenia Y Ave
Colonia del Valle
C.P. 03100, Mexico
Tel: (5) 660-4323, TLX: (383) 1771038

Morocco
Oussama S.A.
Angle Boulevard Emile Zola et
Rue Rehel
P.O. Box 2007 Casa
Casablanca
Morocco
Tel: 24-13-38, TLX 22730 M

Nepal
Associated Enterprises
G.P.O. Box 790, Pyaphal Toie
Kathmandu, Nepal
Tel: 13868

Netherlands
Fluke (Holland) B.V.
P.O. Box 2269
5600 CG Eindhoven
Netherlands
Tel: (40) 458045, TLX: (844) 51846
Fluke (Nederland) B.V.
Gasthuisring 14
P.O. Box 115
5000 AC Tilburg
The Netherlands
Tel: (13) 352455, TLX: (844) 52683

New Zealand
Northrop Instruments & Systems, Ltd
Information Technology Group
459 Khyber Pass Road
Private Bag, Newmarket
Auckland 1, New Zealand
Tel: (9) 501-801, TLX: (791) 21570

Northrop Instruments & Systems Ltd
Information Technology Group
First Floor, Northrop Bldg
189-191 Willis Street
P.O. Box 2406
Wellington, New Zealand
Tel: (4) 856-656, TLX: (791) 3380

Northrop Instruments & Systems Ltd
Information Technology Group
110 Mandeville Street
P.O. Box 8386
Christchurch, New Zealand
Tel: (3) 488-874, TLX: (791) 4801

Norway
Morgensterne & Co A/S
Konghellegate 3
P.O. Box 6688, Rodelokka
Oslo 5, Norway
Tel: (2) 356110, TLX: (856) 71719

Oman
OHI Telecommunications
P.O. Box 889
Muscat
Sultanate of Oman
Tel: 603606, TLX: (926) 5052

Pakistan
International Operations (PAK), Ltd.
505 Muhammadi House
I.I. Chundrigar Road
P.O. Box 5323, Karachi, Pakistan
Tel: (21) 221127, TLX: (952) 24494

Peru
Importaciones y Representaciones
Electronicas S.A.
Avda. Franklin D. Roosevelt 105
Lima 1, Peru
Tel: (14) 28-8650, TLX: (394) 25663

Philippines, Republic of
Spark Radio & Electronics, Inc.
452 Shaw Boulevard
Mandaluyong, Metro Manila
Republic of Philippines
Tel: (2) 775192, TLX: (722 or 732) 27901

Poland
Amtest Associates Ltd.
Clarence House, 31 Clarence St.
Staines, Middlesex TW18 4SY
England
Tel: (784) 63555, TLX: (851) 928855

Portugal
Decada Espectral
Equipamentos de Electronica
Av. Bombeiros Voluntarios
Lote 102B, Miraflores/Alges
1495 Lisbon, Portugal
Tel: (1) 2103420, TLX: (832) 15515

Romania
Amtest Associates Ltd.
Clarence House, 31 Clarence St.
Staines, Middlesex TW18 4SY
England
Tel: (784) 63555, TLX: (851) 928855

Saudi Arabia
Electronic Equipment Marketing Co.
P.O. Box 3750
Riyadh, Saudi Arabia
Tel: (1) 477-1650, TLX: 201120

Singapore, Republic of
Rank O'Connor's (PTE) Ltd
O'Connor House
98 Pasir Panjang Road
Singapore 0511
Republic of Singapore
Tel: 4737944, TLX: (786) RS21023

South Africa
Fluke S.A. (Pty) Ltd
Wynberg Park
777 Andries Street
Wynberg, South Africa
Tel: (11) 786-3170, TLX: (960) 424328

Spain
ESSA
Equipos y Sistemas S.A.
C/Apolonio Morales, 13-B
Madrid 16, Spain
Tel: (1) 458-0150, TLX: (831) 42856

Sri Lanka
Computerlink Data Systems, Ltd
294 Union Place
Colombo 2, Sri Lanka
Tel: (1) 28641/2, TLX: (954) 21321

Sweden
Teleinstrument AB
Maitesholmsvagen 138
P.O. Box 4490
162 04 Vallingby 4
Sweden
Tel: (8) 380370, TLX: (854) 15770

Switzerland
Traco Electronic AG
Jenatschstrasse 1
8002 Zurich
Switzerland
Tel: (1) 201-0711, TLX: (845) 815570

Syria
Mabek (Electronics Division)
P.O. Box 4238
Damascus, Syria

Taiwan
Schmidt Electronics Corp.
5th Fl, Cathay Min Sheng
Commercial Building,
344 Min Sheng East Road
Taipei 104, Taiwan R.O.C.
Tel: (2) 501-3468, TLX: (785) 11111

Thailand
Measuretronix Ltd.
2102/63 Ramkhamhaeng Rd.
Bangkok 10240
Thailand
Tel: (2) 378-2516, TLX: (788) 82796

Tunisia
Selep S.A.R.L.
6, Rue de Sparte
Tunis - 1000 RP
Tunisia
Tel: (1) 248093, TLX: (934) 13030

Turkey
Erkman Elektronik Aletler
Ticaret Anonim Sirketi
Necatibey Cad 92/3
Karakoy, Istanbul, Turkey
Tel: (11) 4415461, TLX: (821) 24399

United Arab Emirates
Al-Sanani Cen. Trad. Est.
P.O. Box 7187
Abu-Dhabi, U.A.E.
Tel: (2) 821370 or 821371
TLX: (958) 23966

Haris Al-Afag, Ltd.
P.O. Box 545
Sharjah, U.A.E.
Tel: (6) 359120, TLX: (958) 68540

Uruguay
Coasin Uruguay S.A.
Libertad 2529
Casilla de Correo 1400
Montevideo, Uruguay
Tel: (2) 789015, TLX: (398) UY23010

USSR
Amtest Associates Ltd.
Clarence House, 31 Clarence St.
Staines, Middlesex TW18 4SY
England
Tel: (784) 63555, TLX: (851) 928855

Venezuela
Coasin C.A.
Calle 9 Con Calle 4, Edif Edinurbi
Apartado de Correos NR-70.136
Los Ruices
Caracas 1070-A, Venezuela
Tel: (2) 239-0967, TLX: (395) 21027

Yugoslavia
Amtest Associates Ltd.
Clarence House, 31, Clarence St.
Staines, Middlesex TW18 4SY
England
Tel: (784) 63555, TLX: (851) 928855

Supplied and Supported by —
Fluke (Holland) B.V.
P.O. Box 2269
5600 CG Eindhoven
Netherlands
Tel: (040) 45805, TLX: 51846
FAX: 31-40-457515

Supplied and Supported by —
Fluke International Corporation
P.O. Box C9090
Everett, WA 98206 U.S.A.
Tel: (206) 356-5500
TLX: 185103 FLUKE UT
FAX: 206-356-5116

The following countries are
represented by:
Fluke (Holland) B.V.
P.O. Box 2269
5600 CG Eindhoven
Netherlands
Tel: (040) 45805, TLX: 51846
FAX: 31-40-457515

Abu Dhabi
Alghanistan
Albania
Algeria
Angola
Berlin
Borholm
Botswana
Chad
Corsica
Czechoslovakia
Dubai
Ethiopia
Guinea
Ibiza
Iceland
Iraq
Kuwait
Liberia
Libya
Luxembourg
Maderia
Mallorca
Mauritania
Menorca
Mongolia
Niger
Nigeria
Qatar
Rochos
Russia
Sardinia
Saudi Arabia
Scotland
Senegal
Sierra Leone
Somalia
Togo
Upper Volta
Wales
Watin Sahara
Yemen
Zaire
Zambia
Zimbabwe

FLUKE[®]

U.S.A.

CA, Burbank

John Fluke Mfg. Co., Inc.
Tel: (213) 849-7181

CA, Santa Clara

John Fluke Mfg. Co., Inc.
Tel: (408) 727-0513

CO, Denver

John Fluke Mfg. Co., Inc.
Tel: (303) 695-1000

FL, Orlando

John Fluke Mfg. Co., Inc.
Tel: (305) 896-4881

IL, Palatine

John Fluke Mfg. Co., Inc.
Tel: (312) 398-5800
Tel: (312) 392-9510

MD, Rockville

John Fluke Mfg. Co., Inc.
Tel: (301) 770-1576

NJ, Paramus

John Fluke Mfg. Co., Inc.
Tel: (201) 262-8550

TX, Dallas

John Fluke Mfg. Co., Inc.
Tel: (214) 869-0311

WA, Everett

John Fluke Mfg. Co., Inc.
Tel: (206) 356-5560

Other Countries

Argentina, Buenos Aires

Coasin S.A.
Tel: 552-5248
TLX: (390) 22284

Australia, Melbourne

Elmeasco Instruments Pty. Ltd.
Tel: 369-9698
TLX: (790) AA44062

Australia, Concord

Elmeasco Instruments Pty. Ltd.
Tel: 736-2888
TLX: (790) AA25887

Australia, Ringwood

Elmeasco Instruments Pty. Ltd.
Tel: 879-2322
TLX: (790) AA36206

Austria, Vienna

Walter Rekirsch
Elektronische Geräte GmbH & Co.
Tel: 235555
TLX: (847) 134759

Belgium, Brussels

Fluke (Belgium) SA/NA
Tel: 2164090
TLX: (846) 26312

Brazil, Sao Paulo

Hi-Tek Eletronica Ltda.
Tel: 421-5477
TLX: (1391) 1135589

Canada, Burnaby, BC

Allan Crawford Associates Ltd.
Tel: (604) 294-1326
TLX: 0454247

Canada, Calgary, AB

Allan Crawford Associates Ltd.
Tel: (403) 291-3477
TLX: 03821186

Canada, Mississauga, ON

Allan Crawford Associates Ltd.
Tel: (416) 890-2010
TLX: 0696 1235

Canada, St. Laurent, PQ

Allan Crawford Associates Ltd.
Tel: (514) 731-8564
TLX: 05824946

Chile, Santiago

Instrumentos Chile Ltda.
Tel: 49840
TLX: (332) 240301

China, Peoples Republic of

Instrumentos - Fluke Service Center
Tel: 65-1261

Colombia, Bogota

Sistemas e Instrumentacion, Ltda.
Tel: 224-3332
TLX: (396) 45787

Denmark, Odense

Tage Olesen A/S
Tel: 658111
TLX: (855) 35293

Ecuador, Quito

Proteco Coasin Cia., Ltda.
Tel: 526758
TLX: (383) 2865

Egypt and Sudan

Electronic Engineering Liaison Office
Tel: 695705
TLX: (927) 22782

England, Watford, Herts

Fluke (Great Britain) LTD
Tel: 40511
TLX: (851) 834583

Finland

Instrumentarium Elektronikka
Tel: 358-0-5281
TLX: (857) 124426

France

M.B. Electronique S.A.
Tel: 9568131
TLX: (842) 695414

Greece, Athens

Hellenic Scientific Representations
Tel: 7211140
TLX: (843) 218380

Hong Kong, Kowloon

Schmet & Co (H.K.) Ltd.
Tel: 6330-222
TLX: (780) 74766

India, Bangalore

Hinditron Services Pvt. Ltd.
Tel: 33139
TLX: (953) 845741

India, Bombay

Hinditron Services Pvt. Ltd.
Tel: 8121316
TLX: (953) 112326

India, New Delhi

Hinditron Services Pvt. Ltd.
Tel: 640380
TLX: (953) 316458

Indonesia, Jakarta Pusat

P.T. Dwi Tunggal Jaya Sakti
Tel: 584685
TLX: (796) 47306

Israel, Ramat Hasharon

R.D.T. Electronics Engineering Ltd.
Tel: 483211
TLX: (922) 32143

Italy, Milan

Sistrel S.p.A.
Tel: 6181893
TLX: (843) 334643

Japan, Tokyo

John Fluke Mfg. Co., Inc.
Japan Branch
Tel: 434-0181
TLX: (781) 242-4331

Korea, Republic of

Electro-Science Korea Co.
Tel: 784-9942
TLX: MYOUNG K24283

Malaysia, Petaling Jaya

Mecomb Malaysia SDN BHD
Tel: 743422
TLX: (784) MA37764

Mexico

Industrial, S.A. (Mexel)
Diagonal No. 27
Entre Calle de Eugenia Y Ave.
Colonias del Valle
C.P. 03100, Mexico
Tel: 680-4323
TLX: (383) 1771038

Netherlands, Tilburg

Fluke (Nederland) B.V.
Tel: 352456
TLX: (844) 52683

New Zealand, Auckland

McLean Information Technology, Ltd.
Tel: 501-801, 501-219
TLX: (791) 21570

Norway, Oslo

Morgenstjerne & Co. A/S
Tel: 356110
TLX: (856) 71719

Pakistan, Karachi

International Operations (PAIQ), Ltd.
Tel: 221127, 239052
TLX: (952) 24494

Peru, Lima

Importaciones Y Representaciones
Electronicas S.A.
Tel: 288650
TLX: (394) 25663

Philippines, Republic of

Spark Radio & Electronics Corp.
Tel: 775192
TLX: (722) 27901

Portugal, Lisbon

Decada Espectral Equipamentos
de Electronica, Lda.
Tel: 2103420
TLX: (832) 15515

Republic of Singapore, Singapore

Rank O'Connor's (PTE) Limited
Tel: 4737944
TLX: (786) RS21023

Republic of South Africa

Fluke S.A. (Pty) Ltd.
Tel: 786-3170
TLX: (850) 424328

Spain, Madrid

Equipos y Sistemas S.A.
Tel: 458-0150
TLX: (831) 42856

Sweden, Vallingby

Teleinstrument AB
Tel: 380370
TLX: (854) 15770

Switzerland, Zurich

Traco Electronic AG
Tel: 2010711
TLX: (845) 815570

Taiwan, Taipei

Schmidt Electronics Corp.
Tel: 5013468
TLX: (785) 11111

Thailand, Bangkok

Measuretronix Ltd.
Tel: 378-2516
TLX: (788) 82796

Turkey, Istanbul

Erkman Elektronik Aletler
Tel: 4415461
TLX: (821) 24399

Uruguay, Montevideo

Coasin Uruguaya S.A.
Tel: 789015
TLX: (398) UY23010

Venezuela, Caracas

Coasin C.A.
Tel: 239-0967
TLX: (395) 21027

West Germany, Ismaning/Munich

Fluke (Deutschland) GmbH
Tel: 96050
TLX: (841) 0522472



John Fluke Mfg. Co., Inc., P.O. Box 69000, Everett, WA 98206
Fluke (Holland) B.V., P.O. Box 2269, 5000 CG, Eindhoven, The Netherlands. Phone (040) 458045, TLX 51848
Litho in U.S.A. 11/85